

KitchenAid, Maytag and Whirlpool

TECHNICAL EDUCATION

2012/2013 29 cu. ft. 36 in. Wide French Door Bottom Mount Dual Evaporator Refrigerators



KFIS29BBBL, KFIS29BBMS, KFIS29BBWH, MFT2976AEB,
MFT2976AEB, MFT2976AEB, WRFIS29PBMS, WRF759SLAW,
WRF759SLAF, WRF759SLAB, WR59SLAM, WRF789SDAB,
WRF989SDAE, WRF989SDAF, WRF989SAH, WRF989SDAM,
WRF989SDAW, WRF989SLAB, WRF989SLAW, WRF989SLAM,
WRF989SLAF, WRF990SLAB, WRF990SLAM, WRF990SLAW.

*All Colors

FORWARD

This Job Aid, 2012/2013 KitchenAid, Maytag and Whirlpool 29 cu. ft. 36 in. wide French Door Dual Evaporator Bottom Mount Refrigerators (Part No. W10444924) provides the In-Home Service Professional with information on the installation, operation, and service of these refrigerators. For specific information on the model being serviced, refer to the “Use and Care Guide,” or “Tech Sheet” provided with the refrigerator.

The Wiring Diagrams used in this Job Aid are typical and should be used for training purposes only. Always use the Wiring Diagram supplied with the product when servicing the refrigerator.

GOALS AND OBJECTIVES

The goal of this Job Aid is to provide information that will enable the In-Home Service Professional to properly diagnose malfunctions and repair these refrigerators.

The objectives of this Job Aid are to:

- Understand and follow proper safety precautions.
- Recognize installation.
- Successfully access components.
- Successfully troubleshoot and diagnose malfunctions.
- Successfully perform necessary repairs.
- Successfully return the refrigerator to its proper operational status.

WHIRLPOOL CORPORATION assumes no responsibility for any repairs made on our products by anyone other than authorized In-Home Service Professionals.

TABLE OF CONTENTS

KITCHENAID, MAYTAG AND WHIRLPOOL 2012/2013 29 CU. FT. 36 IN. WIDE FRENCH DOOR BOTTOM MOUNT DUAL EVAPORATOR REFRIGERATORS

SECTION 1 - GENERAL INFORMATION

Refrigerator Safety	1-2
Model Numbers	1-5
Dimensions and Features	1-6
Model & Serial Number Label	1-8
Tech Sheet Location	1-8

SECTION 2 - INSTALLATION

Unpack the Refrigerator	2-2
Location Requirements	2-2
Remove and Replace Refrigerator Doors	2-3
Remove and Replace Freezer Drawer Front	2-6
Electrical Requirements	2-7
Water Supply Requirements	2-7
Connect the Water Supply	2-7
Handle Installation and Removal	2-9
Refrigerator Leveling Door Closing and Alignment	2-10
Water Filtration System	2-12
Install Air Filter	2-13
Install Produce Preserver	2-14
Accessories	2-15
Opening and Closing Doors	2-15

SECTION 3 - CONTROLS AND OPERATING INSTRUCTIONS

Using the Controls	3-2
Water and Ice Dispensers	3-5
Ice Maker and Storage Bin	3-8
Refrigerator Shelves	3-9
Crisper and Crisper Cover	3-10
Temperature-Controlled Drawer	3-10
Door Bins	3-11
Pizza Pocket and Drawer Divider	3-11
Cleaning	3-12
Lights	3-13
Vacation and Moving Care	3-13

SECTION 4 - THEORY OF OPERATION

XXL French Door Bottom Mount Cut Away	4-2
High Side Assembly	4-3
Dual Evaporator Refrigerant System	4-4
Cooling Operation - Pull Down	4-10
Cooling Operation - Normal Cooling	4-10

SECTION 5 - COMPONENT ACCESS

Machine Compartment Components	5-2
Refrigerator Compartment Components	5-5
Freezer Compartment Components	5-12
Ice Maker and Dispenser Components	5-15

SECTION 6 - DIAGNOSTICS AND TROUBLESHOOTING

Safety	6-2
Tech Sheet Layout	6-2
Service Diagnostics	6-8
Troubleshooting	6-15

SECTION 7 - REFRIGERANT RECOVERY AND CHARGING PROCEDURES

Sealed System Repair	7-2
Representative Examples of Equipment, Tools and Supplies	7-3
Equipment, Tools and Supplies	7-3
Key Components	7-4
Phase One: Initial Hook Up	7-5
Phase Two: Refrigerant Recovery	7-7
Phase Three: Make Repairs	7-8
Phase Four: Evacuation	7-9
Phase Five: Charging	7-11

PRODUCT SPECIFICATIONS & WARRANTY INFORMATION SOURCES (inside back cover)

Section 1: General Information

This section provides general information concerning KitchenAid, Maytag and Whirlpool Dual Evaporator French Door Refrigerators.

- Refrigerator Safety
- Proper Disposal of Your Old Refrigerator
- Model Numbers
- Dimensions and Features
- Model & Serial Number Label
- Tech Sheet Locations

GENERAL INFORMATION

Refrigerator Safety

Your safety and the safety of others are very important.

We have provided many important safety messages in this manual and on your appliance. Always read and obey all safety messages.



This is the safety alert symbol.

This symbol alerts you to potential hazards that can kill or hurt you and others.

All safety messages will follow the safety alert symbol and either the word "DANGER" or "WARNING."

These words mean:

⚠ DANGER

You can be killed or seriously injured if you don't immediately follow instructions.

⚠ WARNING

You can be killed or seriously injured if you don't follow instructions.

All safety messages will tell you what the potential hazard is, tell you how to reduce the chance of injury, and tell you what can happen if the instructions are not followed.

IMPORTANT SAFETY INSTRUCTIONS

WARNING: To reduce the risk of fire, electric shock, or injury when using your refrigerator, follow these basic precautions:

- Plug into a grounded 3 prong outlet.
- Do not remove ground prong.
- Do not use an adapter.
- Do not use an extension cord.
- Disconnect power before servicing.
- Replace all parts and panels before operating.
- Remove doors from your old refrigerator.
- Use nonflammable cleaner.
- Keep flammable materials and vapors, such as gasoline, away from refrigerator.
- Use two or more people to move and install refrigerator.
- Disconnect power before installing ice maker (on ice maker kit ready models only).
- Use a sturdy glass when dispensing ice (on some models).
- Do not hit the refrigerator glass doors (on some models).

SAVE THESE INSTRUCTIONS

State of California Proposition 65 Warnings:

WARNING: This product contains one or more chemicals known to the State of California to cause cancer.

WARNING: This product contains one or more chemicals known to the State of California to cause birth defects or other reproductive harm.

NOTICE TO THE TECHNICIAN

It is the responsibility of the Service Technician to comply with all EPA Regulations and Standards and possess all necessary State and Federal licenses when servicing refrigerators.

Federal regulations and Standards can be found on the United States Government EPA Web Site.

State Regulations and Standards and licensing requirements, in most cases, can be found on the State Government Web Site.

Refrigerator Safety (cont.)

⚠️ WARNING

Excessive Weight Hazard

Use two or more people to move and install refrigerator.

Failure to do so can result in back or other injury.

Important information to know about glass shelves and covers:

Do not clean glass shelves or covers with warm water when they are cold. Shelves and covers may break if exposed to sudden temperature changes or impact, such as bumping. Tempered glass is designed to shatter into many small, pebble-size pieces. This is normal. Glass shelves and covers are heavy. Use both hands when removing them to avoid dropping.

When Moving Your Refrigerator:

Your refrigerator is heavy. When moving the refrigerator for cleaning or service, be sure to cover the floor with cardboard or hardboard to avoid floor damage. Always pull the refrigerator straight out when moving it. Do not wiggle or “walk” the refrigerator when trying to move it, as floor damage could occur.

⚠️ WARNING



Electrical Shock Hazard

Disconnect power before servicing.

Replace all parts and panels before operating.

Failure to do so can result in death or electrical shock.

⚠️ WARNING



Electrical Shock Hazard

Plug into a grounded 3 prong outlet.

Do not remove ground prong.

Do not use an adapter.

Do not use an extension cord.

Failure to follow these instructions can result in death, fire, or electrical shock.

ELECTRICAL: A 115-volt, 60-Hz, AC-only, 15- or 20-amp fused, grounded electrical supply is required. It is recommended that a separate circuit serving only your refrigerator be provided. Use an outlet that cannot be turned off by a switch. Do not use an extension cord.

NOTE: Before performing any type of installation, cleaning, or removing a light bulb, turn the control (Thermostat, Refrigerator or Freezer Control depending on the model) to OFF and then disconnect the refrigerator from the electrical source. When you are finished, reconnect the refrigerator to the electrical source and reset the control (Thermostat, Refrigerator or Freezer Control depending on the model) to the desired setting. See “Using the Controls.”

WATER: A cold water supply with water pressure between 35 and 120 psi (241 and 827 kPa) is required to operate ice maker and water dispenser. If you have questions about your water pressure, call a licensed, qualified plumber.

IMPORTANT: The pressure of the water coming out of a reverse osmosis system going to the water inlet valve of the refrigerator needs to be between 35 and 120 psi (241 and 827 kPa).

REVERSE OSMOSIS WATER SUPPLY: If a reverse osmosis water filtration system is connected to your cold water supply, the water pressure to the reverse osmosis system needs to be a minimum of 40 to 60 psi (276 to 414 kPa).

GENERAL INFORMATION

Refrigerator Safety (cont.)

⚠ DANGER

Electrical Shock Hazard Only authorized technicians should perform diagnostic voltage measurements. After performing voltage measurements, disconnect power before servicing. Failure to follow these instructions can result in death or electrical shock.

Voltage Measurement Safety Information
When performing live voltage measurements, you must do the following:
<ul style="list-style-type: none"><input type="checkbox"/> Verify the controls are in the off position so that the appliance does not start when energized.<input type="checkbox"/> Allow enough space to perform the voltage measurements without obstructions.<input type="checkbox"/> Keep other people a safe distance away from the appliance to prevent potential injury.<input type="checkbox"/> Always use the proper testing equipment.<input type="checkbox"/> After voltage measurements, always disconnect power before servicing.

Proper Disposal of Your Old Refrigerator

⚠ WARNING
Suffocation Hazard
Remove doors from your old refrigerator. Failure to do so can result in death or brain damage.

IMPORTANT: Child entrapment and suffocation are not problems of the past. Junked or abandoned refrigerators are still dangerous – even if they will sit for “just a few days.” If you are getting rid of your old refrigerator, please follow these instructions to help prevent accidents.

Before You Throw Away Your Old Refrigerator or Freezer:

- Take off the doors.
- Leave the shelves in place so that children may not easily climb inside.

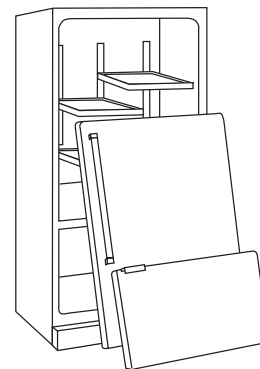

Important information to know about disposal of refrigerators:

Dispose of refrigerator in accordance with Federal and Local regulations. Refrigerants must be evacuated by a licensed, EPA certified refrigerant technician in accordance with established procedures.

Model Numbers



KitchenAid Interior

KitchenAid Models

KFIS29BBBL, KFIS29BBMS,
KFIS29BBWH, KFIS29PBMS



Whirlpool Interior

Whirlpool Models

WRF989SDAB, WRF989SDAM,
WRF989SDAW, WRF989SDAF,
WRF989SDAE, WRF989SDAH
WRF990SLAM

GENERAL INFORMATION

Model Numbers (cont.)

Maytag Models

MFT2672AEB, MFT2672AEM,
MFT2672AEW, MFT2676AEM,
MFT2676AEW MFT2976AEB



Maytag Interior

Dimensions and Features

Dimensions For All - (Inches)

Capacity	28.6
Cutout Height (in)	69
Cutout Width (in)	36
Depth	35 11/16
Height	70 1/8
Width	35 11/16
Depth Closed Excluding Handles	33 3/16
Depth Closed Including Handles	35 11/16
Depth With Door Open 90 Degree	48
Depth-Drawer Open	47 5/8
Gross Weight	352
Height To Top Of Cabinet	68 5/8
Height To Top Of Door Hinge	69 15/16
Height To Top of Door Trim	70 1/8
Width Doors Open 90 Degrees	38 3/16

Dimensions and Features (cont.)

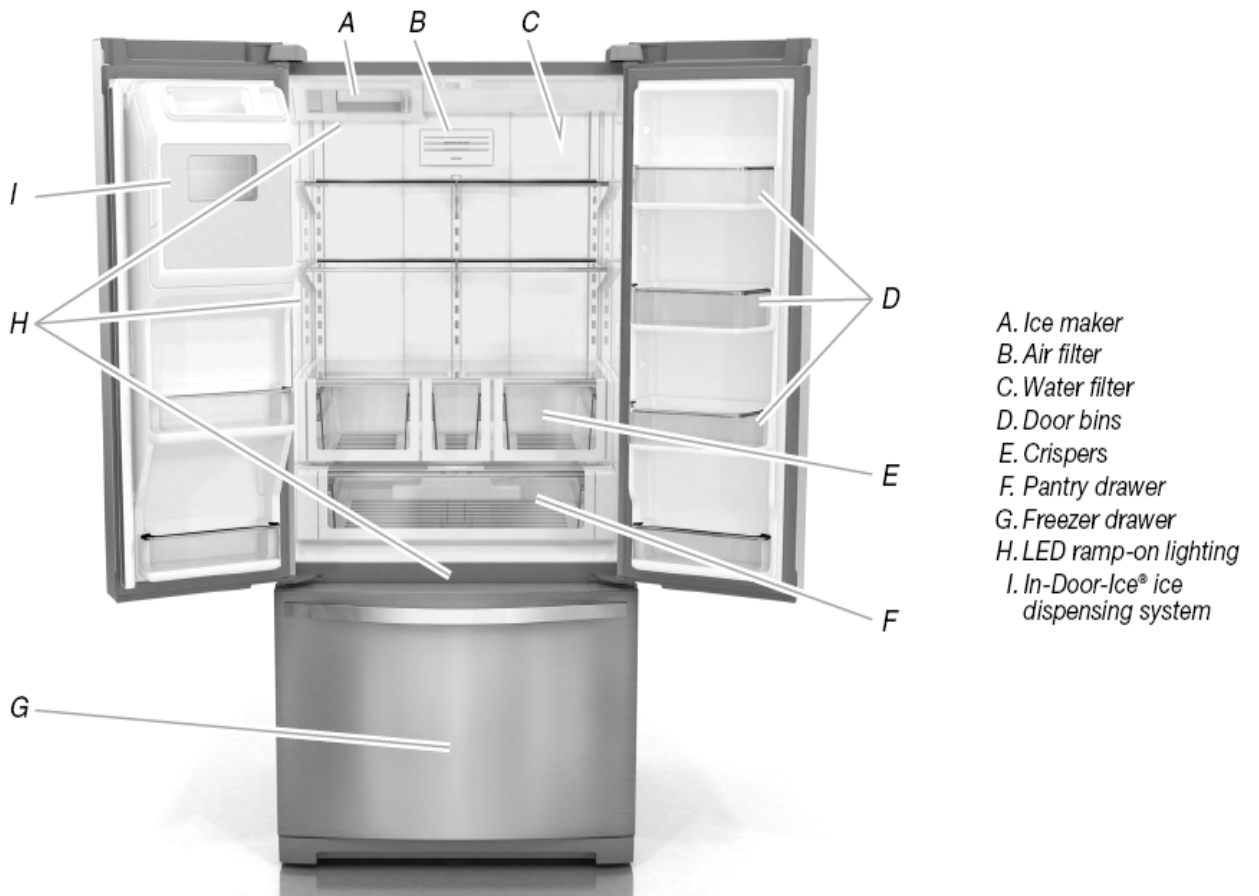

The freezer drawer has been redesigned to include a storage area next to the door for large flat food items.



GENERAL INFORMATION

Model & Serial Number Label



The model number tag is in a new location, on the RC liner above the ice door.

Tech Sheet Location

The Tech Sheet is located under the top right hinge cap of the refrigerator.



Notes

Section 2: Installation

This section provides installation information concerning KitchenAid, Maytag and Whirlpool Dual Evaporator French Door Refrigerators.

- Unpack the Refrigerator
- Location Requirements
- Remove and Replace Refrigerator Doors
- Remove and Replace Freezer Drawer Front
- Electrical Requirements
- Water Supply Requirements
- Connect the Water Supply
- Handle Installation and Removal
- Refrigerator Leveling Door Closing and Alignment
- Water Filtration System
- Install Air Filter
- Install Produce Preserver
- Accessories
- Opening and Closing Doors

INSTALLATION

Unpack the Refrigerator

⚠ WARNING

Excessive Weight Hazard

Use two or more people to move and install refrigerator.

Failure to do so can result in back or other injury.

When Moving Your Refrigerator:

Your refrigerator is heavy. When moving the refrigerator for cleaning or service, be sure to cover the floor with cardboard or hardboard to avoid floor damage. Always pull the refrigerator straight out when moving it. Do not wiggle or “walk” the refrigerator when trying to move it, as floor damage could occur.

Remove the Packaging

- Remove tape and glue residue from surfaces before turning on the refrigerator. Rub a small amount of liquid dish soap over the adhesive with your fingers. Wipe with warm water and dry.
- Do not use sharp instruments, rubbing alcohol, flammable fluids, or abrasive cleaners to remove tape or glue. These products can damage the surface of your refrigerator. For more information, see “Refrigerator Safety.”
- Dispose of/recycle all packaging materials.

Clean Before Using

After you remove all of the packaging materials, clean the inside of your refrigerator before using it. See the cleaning instructions in “Refrigerator Care.”

Important information to know about glass shelves and covers:

Do not clean glass shelves or covers with warm water when they are cold. Shelves and covers may break if exposed to sudden temperature changes or impact, such as bumping. Tempered glass is designed to shatter into many small, pebble-size pieces. This is normal. Glass shelves and covers are heavy. Use both hands when removing them to avoid dropping.

Location Requirements

⚠ WARNING



Explosion Hazard

Keep flammable materials and vapors, such as gasoline, away from refrigerator.

Failure to do so can result in death, explosion, or fire.

NOTE: This refrigerator is intended for use in a location where the temperature ranges from a minimum of 55°F (13°C) to a maximum of 110°F (43°C). The preferred room temperature range for optimum performance, which reduces electricity usage and provides superior cooling, is between 60°F (15°C) and 90°F (32°C). It is recommended that you do not install the refrigerator near a heat source, such as an oven or radiator.

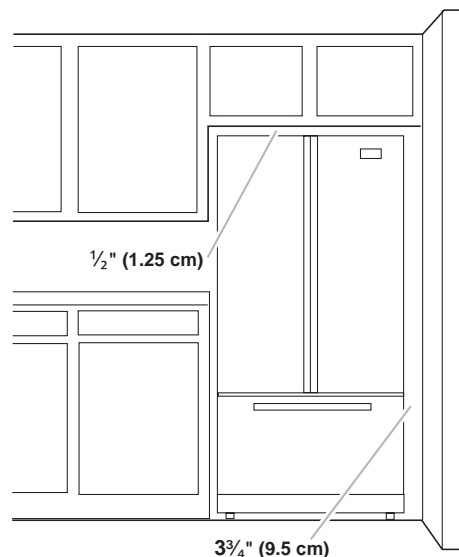

IMPORTANT: This refrigerator is designed for indoor, household use only.

To ensure proper ventilation for your refrigerator, allow for a 1/2" (1.25 cm) of space on each side and at the top. Allow for a 1" (2.54 cm) space behind the refrigerator. If your refrigerator has an ice maker, allow extra space at the back for the water line connections. When installing your refrigerator next to a fixed wall, leave a 3 3/4" (9.5 cm) minimum space between the refrigerator and wall to allow the door to swing open.

Remove and Replace Refrigerator Doors

NOTE: Measure the width of your door opening, to see whether or not you need to remove the refrigerator doors to move the refrigerator into your home. If door removal is necessary, see the following instructions.

IMPORTANT: If the refrigerator was previously installed and you are moving it out of the home, before you begin, turn the refrigerator control OFF. Unplug the refrigerator or disconnect power. Remove food and adjustable door or utility bins from doors.

Gather the required tools and read all instructions before removing doors.

TOOLS NEEDED: $\frac{3}{16}$ " hex key wrench and a #2 Phillips screwdriver



⚠️ WARNING

Electrical Shock Hazard

Disconnect power before removing doors.

Failure to do so can result in death or electrical shock.

Door Removal and Replacement

Style 1 – Water Dispenser Tubing Connection

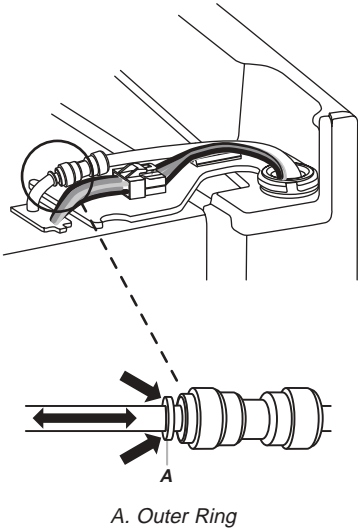

Style 2 – Water Dispenser Tubing Connection

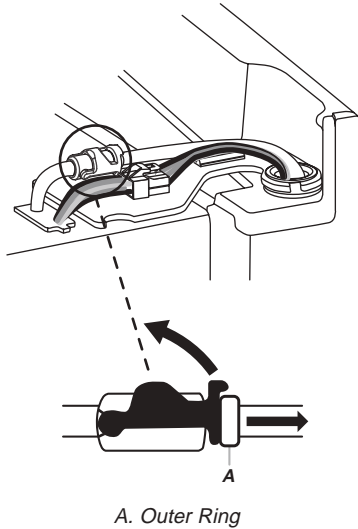

Wiring Plug

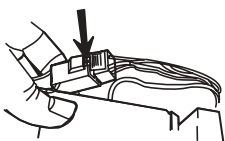

Top Left Hinge

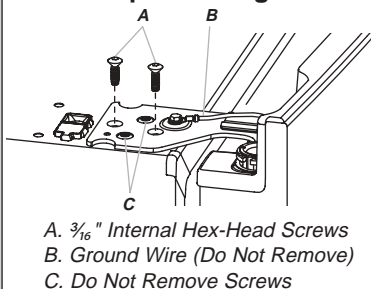

Top Right Hinge

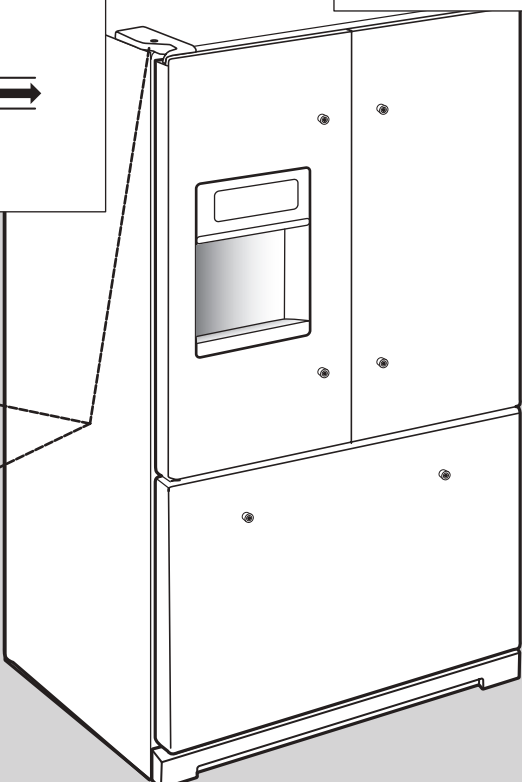
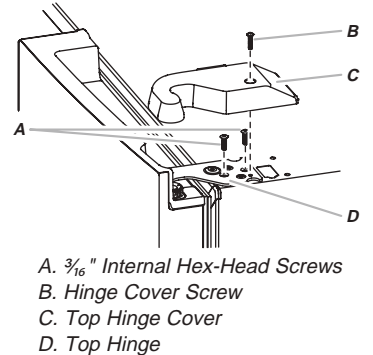

INSTALLATION

Remove Right-Hand Refrigerator Door

⚠️ WARNING



Electrical Shock Hazard

Disconnect power before removing doors.
Failure to do so can result in death or electrical shock.

1. Unplug refrigerator or disconnect power.
2. Keep the refrigerator doors closed until you are ready to lift them free from the cabinet.
NOTE: Provide additional support for the refrigerator door while the hinges are being removed. Do not depend on the door gasket magnets to hold the door in place while you are working.
3. Using a Phillips screwdriver, remove the cover from the Top Hinge.
4. Using the $\frac{3}{16}$ " hex key wrench, remove the two internal hex head screws from the top hinge, and set aside.
NOTE: Do not remove the two locator screws. These screws will help you align the hinge when you replace the door.

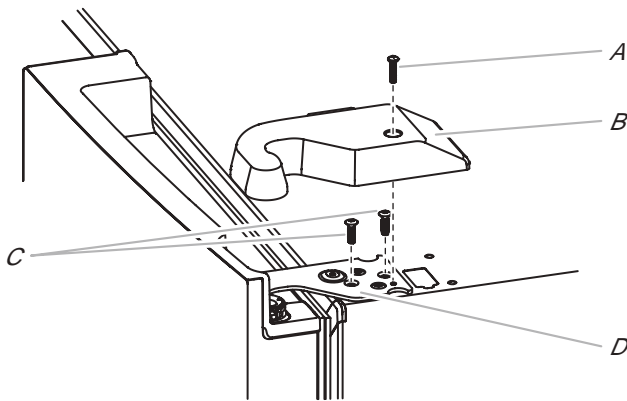

A. Top hinge cover screw C. $\frac{3}{16}$ " Internal hex head screws
B. Top hinge cover D. Top hinge

⚠️ WARNING

Excessive Weight Hazard

Use two or more people to lift the refrigerator door.
Failure to do so can result in back or other injury.

5. Lift the refrigerator door from the bottom hinge pin. The top hinge will come away with the door.

Remove Left-Hand Refrigerator Door

IMPORTANT: The tubing and wiring for the water dispenser run through the left-hand door hinge, so they must be disconnected before removing the door.

1. Using a Phillips screwdriver, remove the cover from the top hinge.

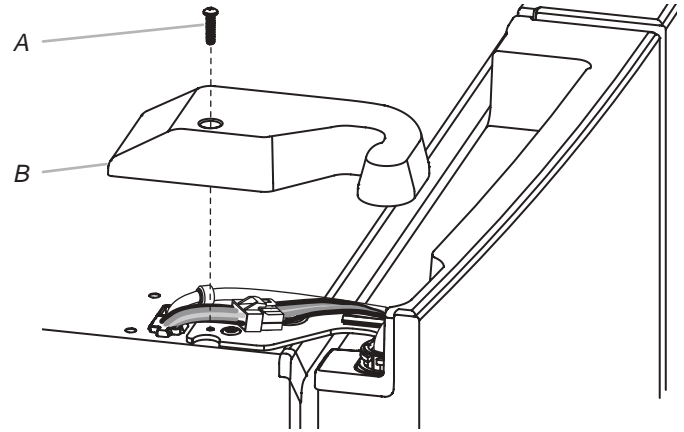

A. Top hinge cover screw B. Top hinge cover

2. Disconnect the water dispenser tubing located on top of the door hinge.

Style 1 - Press the outer ring against the face of the fitting and gently pull the dispenser tubing free.

NOTE: The water dispenser tubing remains attached to the left-hand refrigerator door.

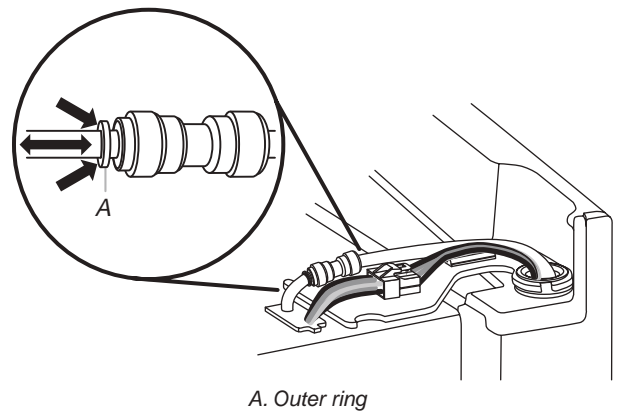

A. Outer ring

Style 2 - Firmly pull up on the clasp. Then, pull the tubing out of the fitting.

NOTE: The water dispenser tubing remains attached to the left-hand refrigerator door.

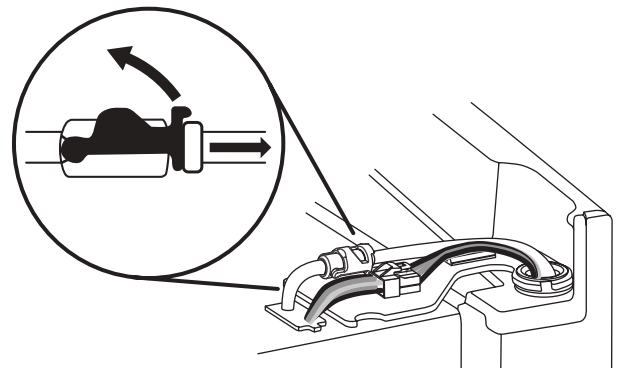

3. Disconnect the wiring plug located on top of the door hinge.
 - Grasp each side of the wiring plug. With your left thumb, press down to release the catch and pull the sections of the plug apart.

NOTE: Do not remove the green, ground wire. It should remain attached to the door hinge.

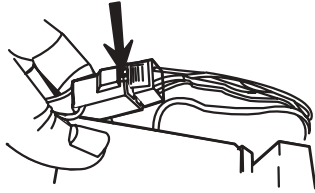

4. Using the $\frac{3}{16}$ " hex key wrench, remove the two internal hex head screws from the top hinge, and set aside.

NOTES:

- Provide additional support for the refrigerator door while the hinges are being removed. Do not depend on the door gasket magnets to hold the door in place while you are working.
- Do not remove the two locator screws. These screws will help you align the hinge when you replace the door.

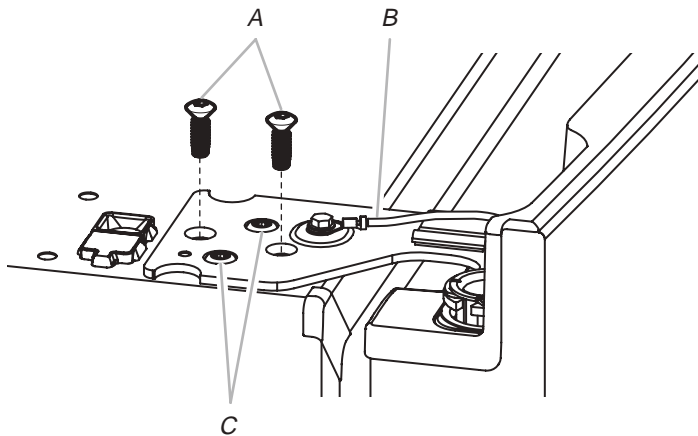

A. $\frac{3}{16}$ " Internal hex head screws
B. Ground wire (do not remove)

C. Locator screws (do not remove)

5. Lift the refrigerator door from the bottom hinge pin. The top hinge will come away with the door.

NOTE: It may not be necessary to remove the bottom hinges and brake feet assemblies to move the refrigerator through a doorway.

 - Only if necessary, use a driver with a #2 square bit tip to remove the bottom hinges and a $\frac{3}{8}$ " nut driver to remove the brake feet screws.

Replace Right-Hand Refrigerator Door

1. Set the right-hand door onto the bottom hinge pin.
2. Insert the top hinge pin into the open hole in the top of the refrigerator door.
3. Using the two $\frac{3}{16}$ " internal hex head screws, fasten the hinge to the cabinet. Do not tighten the screws completely.

Replace Left-Hand Refrigerator Door

IMPORTANT: Do not intertwine the water tubing and wiring bundles when reconnecting them.

1. Set the left-hand door onto the bottom hinge pin.
2. Using the two $\frac{3}{16}$ " internal hex head screws, fasten the hinge to the cabinet. Do not tighten the screws completely.
3. Reconnect the water dispenser tubing.

Style 1 - Insert the tubing into the fitting until it stops and the outer ring is touching the face of fitting.

Style 2 - Insert the tubing firmly into the fitting until it stops. Close the clasp around the tubing. The clasp snaps into place between the fitting and the collar.
4. Reconnect the electrical wiring.
 - Push together the two sections of the wiring plug.

Final Steps

1. Completely tighten the four internal hex head screws (two on the right-hand door hinge and two on the left-hand door hinge).
2. Replace both top hinge covers.

INSTALLATION

Remove and Replace Freezer Drawer Front

Depending on the width of your door opening, it may be necessary to remove the freezer drawer front to move the refrigerator into your home.

IMPORTANT:

- If the refrigerator was previously installed and you are moving it out of the home, before you begin, turn the refrigerator control OFF, and unplug the refrigerator or disconnect power. Remove food from the freezer drawer.
- Two people may be required to remove and replace the freezer drawer front.

Tool Needed: ¼" hex driver

Remove Drawer Front

1. Open the freezer drawer to its full extension.
2. Remove the two screws at the top, inside the drawer front (one on the left-hand side and one on the right-hand side) that fasten the drawer front to the drawer glides.
3. Lift up on the drawer front to release the plastic studs from the drawer glide bracket slots.

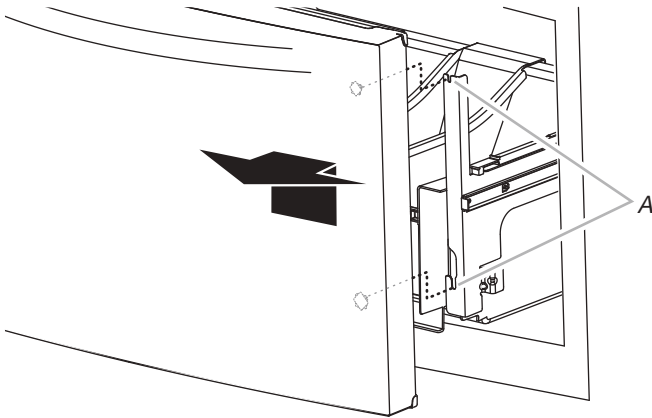

A. Drawer glide bracket slots

4. Slide the drawer glides back into the freezer.

Replace Drawer Front

1. Pull out the freezer drawer glides to their full extension.
2. Holding the drawer front by its sides, align the two plastic studs, located at the bottom, inside the drawer front, with the drawer glide bracket slots.

NOTE: It helps if one person holds the drawer glides steady while another person aligns the drawer front and inserts the studs into the slots.

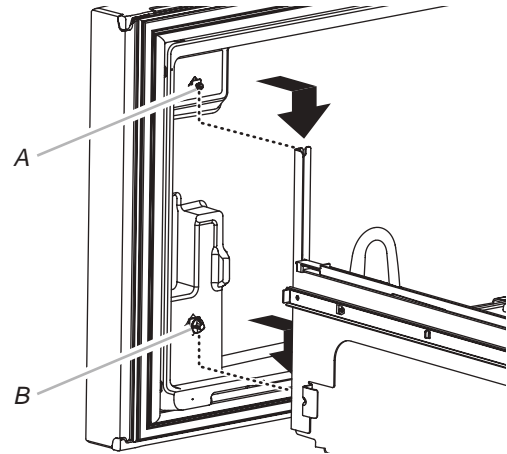

A. Drawer front screw

B. Drawer front plastic stud

3. Replace and tighten the two screws at the top of the drawer front (one on the left-hand side and one on the right-hand side).

Final Steps

⚠ WARNING



Electrical Shock Hazard

Plug into a grounded 3 prong outlet.

Do not remove ground prong.

Do not use an adapter.

Do not use an extension cord.

Failure to follow these instructions can result in death, fire, or electrical shock.

1. Plug into a grounded 3 prong outlet.
2. Reset the controls. See "Using the Control(s)."
3. Return all removable door parts to doors and the food to refrigerator.

Electrical Requirements

⚠ WARNING



Electrical Shock Hazard

Plug into a grounded 3 prong outlet.

Do not remove ground prong.

Do not use an adapter.

Do not use an extension cord.

Failure to follow these instructions can result in death, fire, or electrical shock.

Before you move your refrigerator into its final location, it is important to make sure you have the proper electrical connection.

Recommended Grounding Method

A 115 volt, 60 Hz, AC only 15- or 20-amp fused, grounded electrical supply is required. It is recommended that a separate circuit serving only your refrigerator be provided. Use an outlet that cannot be turned off by a switch. Do not use an extension cord.

NOTE: Before performing any type of installation, cleaning, or removing a light bulb, turn Cooling OFF, and then disconnect the refrigerator from the electrical source. When you have finished, reconnect the refrigerator to the electrical source and turn Cooling ON. See "Using the Control(s)."

Water Supply Requirements

A cold water supply with water pressure between 35 and 120psi (241 and 827kPa) is required to operate the water dispenser and ice maker. If you have questions about your water pressure, call a licensed, qualified plumber.

NOTE: If the water pressure is less than what is required, the flow of water from the water dispenser could decrease or ice cubes could be hollow or irregular shaped.

Reverse Osmosis Water Supply

IMPORTANT: The pressure of the water supply coming out of a reverse osmosis system going to the water inlet valve of the refrigerator needs to be between 35 and 120psi (241 and 827kPa).

If a reverse osmosis water filtration system is connected to your cold water supply, the water pressure to the reverse osmosis system needs to be a minimum of 40 to 60psi (276 to 414kPa).

- Check to see whether the sediment filter in the reverse osmosis system is blocked. Replace the filter if necessary.
- Allow the storage tank on the reverse osmosis system to refill after heavy use. The tank capacity could be too small to keep up with the requirements of the refrigerator.

NOTE: Faucet mounted reverse osmosis systems are not recommended.

If you have questions about your water pressure, call a licensed, qualified plumber.

Connect the Water Supply

Read all directions before you begin.

IMPORTANT:

- Plumbing shall be installed in accordance with the International Plumbing Code and any local codes and ordinances.
- To avoid off-taste or odor in your ice or water, it is recommended that you use copper tubing or Whirlpool® supply tubing, Part Number 8212547RP to connect the household water line with the water line or water fitting coming from the back of the refrigerator. Check for leaks.
- Install tubing only in areas where temperatures will remain above freezing.

TOOLS NEEDED:

Gather the required tools and parts before starting installation.

- Flat-blade screwdriver
- $\frac{7}{16}$ " and $\frac{1}{2}$ " open-end wrenches or two adjustable wrenches
- $\frac{1}{4}$ " nut driver

NOTE: Do not use a piercing-type or $\frac{3}{16}$ " (4.76 mm) saddle valve which reduces water flow and clogs easier.

INSTALLATION

Connect to Water Line

IMPORTANT: If you turn the refrigerator on before the water is connected, turn the ice maker OFF.

1. Unplug refrigerator or disconnect power.
2. Turn OFF main water supply. Turn ON nearest faucet long enough to clear line of water.
3. Use a quarter-turn shutoff valve or the equivalent, served by a ½" household supply line.

NOTE: To allow sufficient water flow to the refrigerator, a minimum ½" size household supply line is recommended.

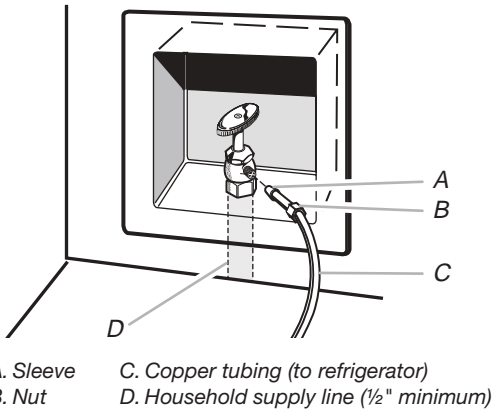

4. Now you are ready to connect the copper tubing to the shutoff valve. Use ¼" (6.35 mm) OD soft copper tubing to connect the shutoff valve and the refrigerator.
 - Ensure that you have the proper length needed for the job. Be sure both ends of the copper tubing are cut square.
 - Slip compression sleeve and compression nut onto copper tubing as shown. Insert end of tubing into outlet end squarely as far as it will go. Screw compression nut onto outlet end with adjustable wrench. Do not overtighten.

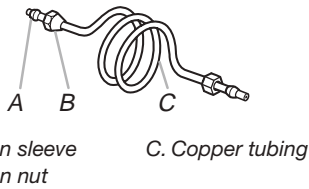

5. Place the free end of the tubing into a container or sink, and turn on main water supply to flush out tubing until water is clear. Turn off shutoff valve on the water pipe.

NOTE: Always drain the water line before making the final connection to the inlet of the water valve, to avoid possible water valve malfunction.
6. Bend the copper tubing to meet the water line inlet, which is located on the back of the refrigerator cabinet as shown. Leave a coil of copper tubing to allow the refrigerator to be pulled out of the cabinet or away from the wall for service.

Connect to Refrigerator

Follow the connection instructions specific to your model.

Style I

1. Remove plastic cap from water valve inlet port. Attach the copper tube to the valve inlet using a compression nut and sleeve as shown. Tighten the compression nut. Do not overtighten. Confirm copper tubing is secure by pulling on copper tubing.
2. Create a service loop with the copper tubing. Avoid kinks when coiling the copper tubing. Secure copper tubing to refrigerator cabinet with a "P" clamp.

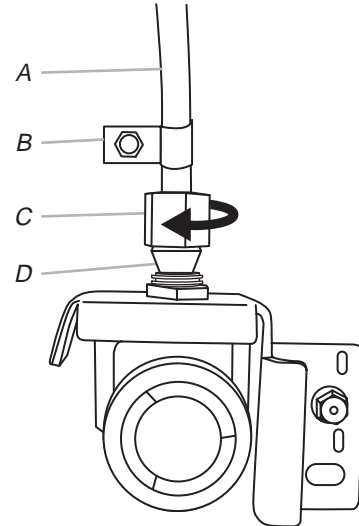

A. Copper tubing
B. "P" clamp
C. Compression nut
D. Compression sleeve

3. Turn on water supply to refrigerator and check for leaks. Correct any leaks.

Style 2

1. Unplug refrigerator or disconnect power.
2. Remove and discard the short, black plastic part from the end of the water line inlet.
3. Thread the nut onto the end of the tubing. Tighten the nut by hand. Then tighten it with a wrench two more turns. Do not overtighten.

NOTE: To avoid rattling, be sure the copper tubing does not touch the cabinet's side wall or other parts inside the cabinet.

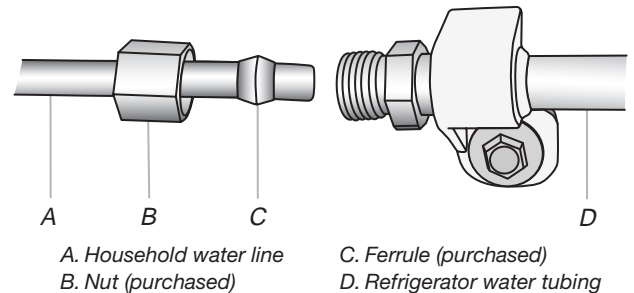

4. Install the water supply tube clamp around the water supply line to reduce strain on the coupling.
5. Turn shutoff valve ON.
6. Check for leaks. Tighten any connections (including connections at the valve) or nuts that leak.
7. On some models, the ice maker is equipped with a built-in water strainer. If your water conditions require a second water strainer, install it in the 1/4" (6.35 mm) water line at either tube connection. Obtain a water strainer from your appliance dealer.

Complete the Installation

⚠ WARNING



Electrical Shock Hazard

Plug into a grounded 3 prong outlet.

Do not remove ground prong.

Do not use an adapter.

Do not use an extension cord.

Failure to follow these instructions can result in death, fire, or electrical shock.

1. Plug into a grounded 3 prong outlet.
2. Flush the water system. See "Water and Ice Dispensers."

NOTE: Allow 24 hours to produce the first batch of ice. Discard the first three batches of ice produced. Allow 3 days to completely fill the ice storage bin.

Handle Installation and Removal

Parts Included: Refrigerator door handles (2), Freezer drawer handle (1), 1/8" hex key, spare setscrew(s)

Install Handles

NOTE: Handle mounting setscrews are preinstalled inside the handle.

1. Remove the handles from the packaging inside the refrigerator, and place them on a soft surface.
2. Open a refrigerator compartment door. On the closed door, place a handle onto the shoulder screws so that the setscrews are facing the adjacent door.

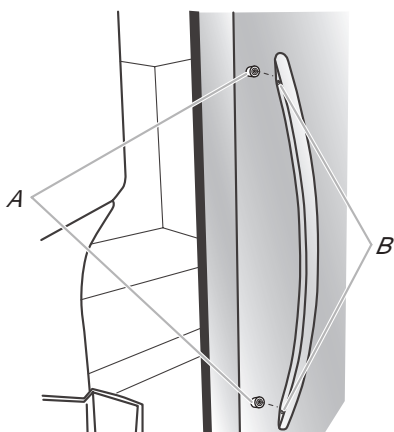

A. Shoulder screws
B. Setscrews inside the handle

3. Firmly push the handle toward the door until the handle base is flush against the door.
4. While holding the handle, insert the short end of the hex key into the upper hole and slightly rotate the hex key until it is engaged in the setscrew.

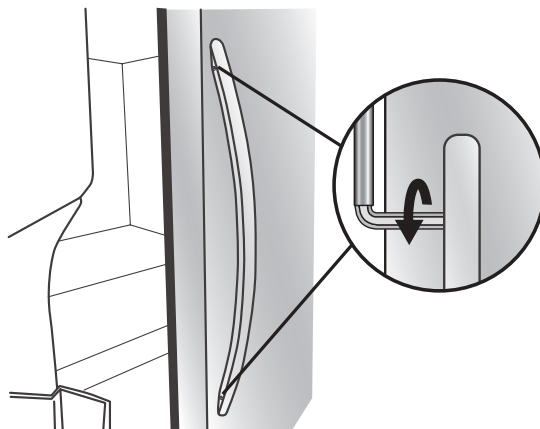

5. Using a clockwise motion tighten the setscrew just until it begins to contact the shoulder screw. Do not fully tighten.
6. Repeat steps 4 and 5 to fasten the lower setscrew.
7. Once both setscrews have been partially tightened as instructed in the previous steps, fully tighten both setscrews.

IMPORTANT: When the screws feel tight, tighten them an additional quarter-turn. The handle is not properly installed without this extra tightening.

INSTALLATION

- Repeat steps 2 through 7 to install the other handle onto the adjacent refrigerator door.
- With the freezer drawer closed, place the handle onto the shoulder screws so that the setscrews are facing down toward the floor.

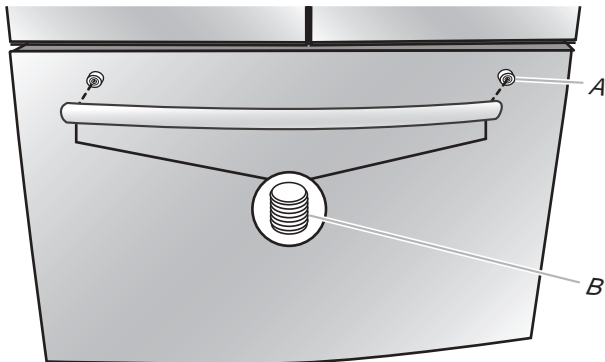

A. Shoulder screw
B. Setscrews inside the handle

- Firmly push the handle toward the drawer until the handle base is flush against the drawer.
- Insert the short end of the hex key into the left-hand hole and slightly rotate the hex key until it is engaged in the setscrew.

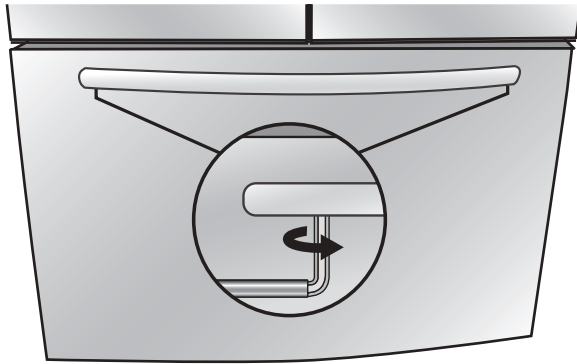

- Using a left to right motion tighten the setscrew a quarter-turn at a time just until it begins to contact the shoulder screw. Do not fully tighten.
- Repeat steps 11 and 12 to fasten the right-hand setscrew to the shoulder screw.
- Once both setscrews have been partially tightened as instructed in the previous steps, fully tighten both setscrews.
IMPORTANT: When the screws feel tight, tighten them an additional quarter-turn. The handle is not properly installed without this extra tightening.
- Save the hex key and all instructions.

Remove the Handles

- While holding the handle, insert the short end of the hex key into a setscrew hole and slightly rotate the hex key until it is engaged in the setscrew.
- Using a right to left motion loosen the setscrew a quarter-turn at a time.
- Repeat steps 1 and 2 for the other setscrew. Slowly pull the handle away from the door or drawer.
- If necessary, use a Phillips screwdriver to remove the shoulder screws from the door.

Refrigerator Leveling, Door Closing and Alignment

The base grille covers the adjustable brake feet and roller assemblies located at the bottom of the refrigerator below the freezer drawer. Before making any adjustments, remove the base grille and move the refrigerator to its final location.

Tools Needed: 1/4" hex driver

Tools Provided: 1/8" hex key wrench

- Remove the base grille. Grasp the grille firmly and pull it toward you. Open the freezer drawer to access the brake feet.
NOTE: To allow the refrigerator to roll easier, raise the brake feet by turning them counterclockwise. The front rollers will be touching the floor.

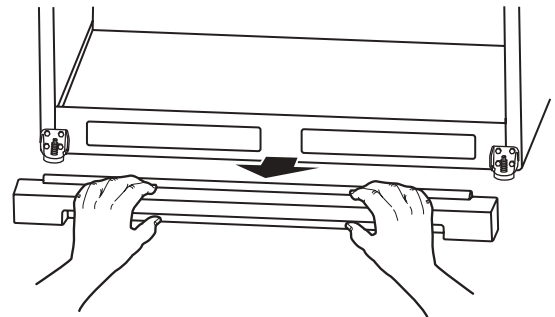

- Move the refrigerator to its final location.
- Lower the brake feet, by turning them clockwise, until the rollers are off the floor and both brake feet are snug against the floor. This keeps the refrigerator from rolling forward when opening the refrigerator doors or freezer drawer.

IMPORTANT: If you need to make further adjustments involving the brake feet, you must turn both brake feet the same amount to keep the refrigerator level.

4. Make sure the doors close easily. If you are satisfied with the door opening and closing, skip the next section and go to "Align the Doors." If, however, the doors do not close easily or the doors pop open, adjust the tilt.

To Adjust the Cabinet Tilt:

- Open the freezer drawer. Use a 1/4" hex driver to turn both brake feet clockwise the same amount. This will raise the front of the refrigerator. It may take several turns to allow the doors to close easier.

NOTE: Having someone push against the top of the refrigerator takes some weight off the brake feet. This makes it easier to turn them.

Style 1

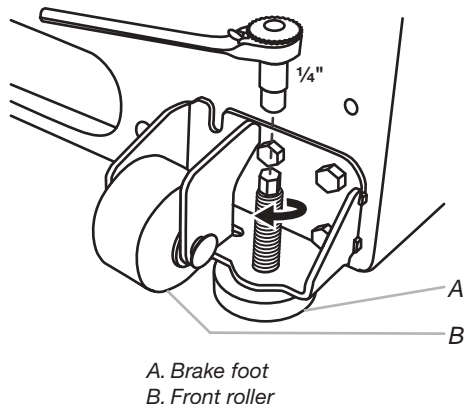

Style 2

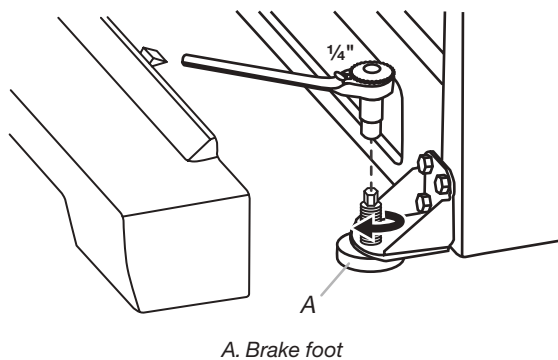

5. Make sure the doors are even at the top and that the space between the bottom of the refrigerator doors and the top of the freezer drawer is even. If necessary, align the doors.

To Align the Doors:

- Keeping both refrigerator doors closed, pull out the freezer drawer. Locate the bottom hinge pin of the right-hand refrigerator door. The alignment screw is inside the bottom hinge pin.

- Insert the short end of the 1/8" hex key wrench (packed with the Door Handle Installation Instructions) into the bottom hinge pin until it is fully engaged in the alignment screw.

To raise the refrigerator door, turn the hex key to the right. To lower the door, turn the hex key to the left.

- Continue to turn the alignment screw until the doors are aligned.

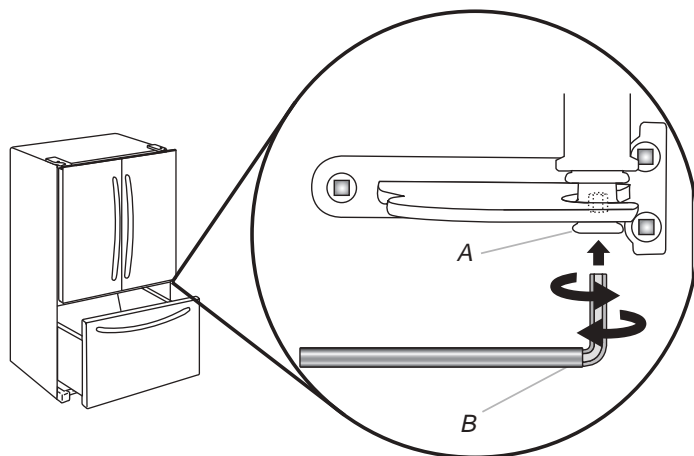

6. Make sure the refrigerator is steady. If the refrigerator seems unsteady or rolls forward when the door or drawer is pulled open, adjust the brake feet.

To Steady the Refrigerator:

- Open the freezer drawer. Using a 1/4" hex driver, turn both brake feet clockwise the same amount until the brake feet are snug against the floor. Check again. If not satisfied, continue to adjust the brake feet by half turns of the screw until the refrigerator does not roll forward when the drawer is opened.

NOTE: Having someone push against the top of the refrigerator takes some weight off the brake feet. This makes it easier to turn the screws.

7. Replace the base grille by aligning the ends of the grille with the leveling assemblies on each side and snapping the grille into place.

INSTALLATION

Water Filtration System

Do not use with water that is microbiologically unsafe or of unknown quality without adequate disinfection before or after the system. Systems certified for cyst reduction may be used on disinfected waters that may contain filterable cysts.

Install the Water Filter

1. Locate the accessory packet in the refrigerator and remove the water filter.
2. Take the water filter out of its packaging and remove the cover from the O-rings. Be sure the O-rings are still in place after the cover is removed.

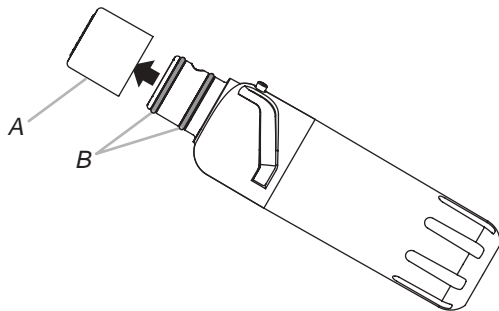

A. O-ring cover
B. O-rings

3. The water filter compartment is located in the right-hand side of the refrigerator ceiling. Push up on the compartment door to release the catch, then lower the door.

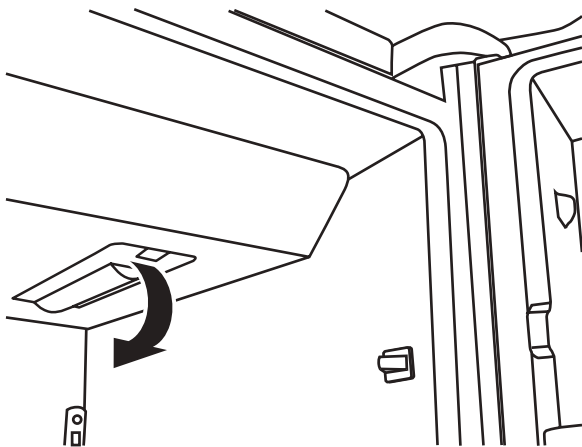

4. Align the arrow on the water filter label with the cutout notch in the filter housing and insert the filter into the housing.

5. Turn the filter clockwise 90 degrees (¼ turn), until it locks into the housing.

NOTE: If the filter is not correctly locked into the housing, the water dispenser will not operate. Water will not flow from the dispenser.

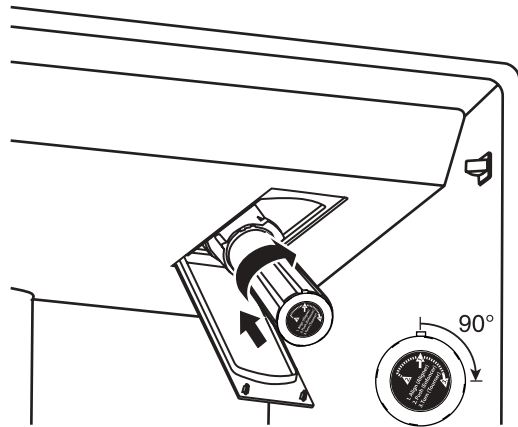

6. While the compartment door is still open, lift the filter up into the compartment. Then, close the filter compartment door completely.
7. Flush the water system. See “Flushing the Water Filter” in the “Water and Ice Dispensers” section.

IMPORTANT: If you do not flush the water system, you may experience dripping and/or decreased flow from the water dispenser.

The Water Filter Status Light

Press **OPTIONS** on the control panel to launch the Options menu. Press **OPTIONS**, under Filter Status, again to display the percentage of filter life remaining (from 100% to 0%). Press **ICE MODE** to return to the Normal screen.

The water filter status lights will help you know when to change your water filter.

- **ORDER** (yellow) - it is almost time to change the water filter. While you are dispensing water, “Order Filter” will blink seven times and sound an alert tone three times.
- **REPLACE** (red) - Replace the water filter. While you are dispensing water, “Replace Filter” will blink seven times and an alert tone will sound three times.
- **RESET** the water filter status tracking feature. After you replace the disposable water filter with a new filter, closing the filter compartment door will automatically reset the filter status tracking feature. See “Using the Controls.”

NOTE: “Replace Filter” will remain illuminated if a filter is not installed or is installed incorrectly.

Replace the Water Filter

To purchase a replacement water filter, see “Accessories.”

Replace the disposable water filter when indicated on the water filter status display or at least every 6 months. If water flow to your dispenser or ice maker decreases noticeably, change the water filter sooner.

1. Locate the water filter compartment in the right-hand side of the refrigerator ceiling. Push up to release and lower the compartment door.

2. Turn the water filter counterclockwise (to the left), and pull it straight out of the compartment.

NOTE: There may be some water in the filter. Some spilling may occur. Use a towel to wipe up any spills.

3. Install the replacement water filter by following steps 2 through 7 in the “Install the Water Filter” section.

Install Air Filter (on some models)

An air filter is 15 times more powerful than baking soda at reducing common food odors inside the refrigerator.

On some models, your refrigerator's accessory packet includes an air filter, which must be installed prior to use.

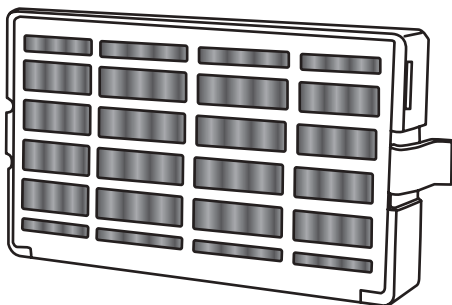

Installing the Air Filter

Install the air filter behind the vented door, located on the rear wall near the top of the refrigerator compartment.

1. Remove the air filter from its packaging.
2. Lift open the vented door.
3. Snap the filter into place.

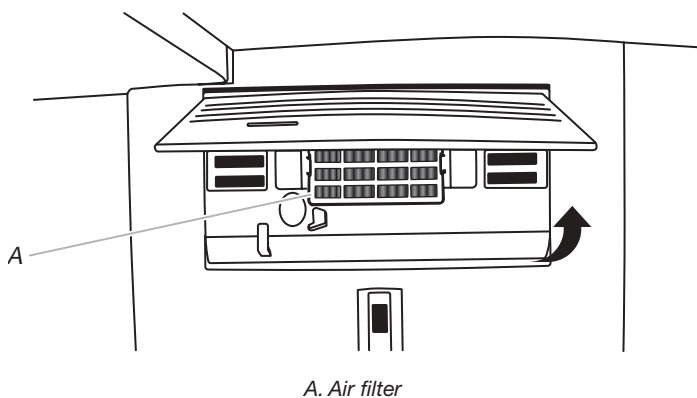

Installing the Filter Status Indicator

The filter comes with a status indicator, which should be activated and installed at the same time the air filter is installed.

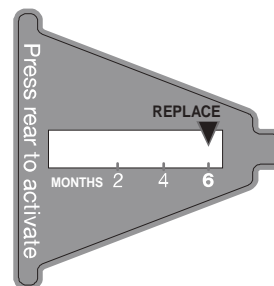

1. Place the indicator face-down on a firm, flat surface.
2. Apply pressure to the bubble on the back of the indicator until the bubble pops to activate the indicator.
3. Lift open the vented air filter door. On some models, there are notches behind the door.

Models with notches:

- With the indicator screen facing outward, slide the indicator down into the notches.

NOTE: The indicator will not easily slide into the notches if the bubble has not been popped.

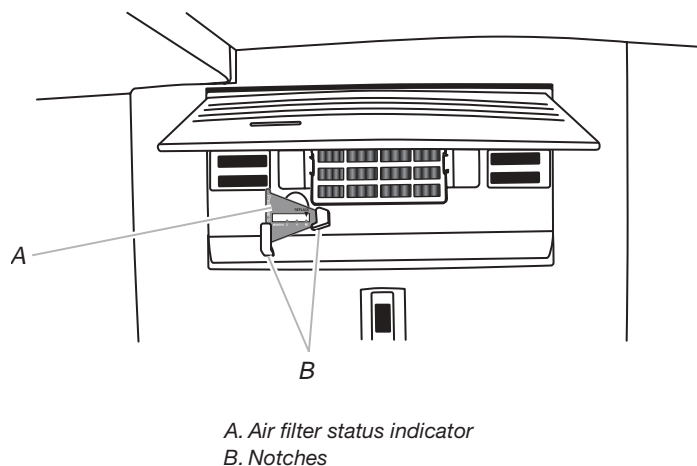

INSTALLATION

- Close the air filter door, and check that the indicator is visible through the window in the door.

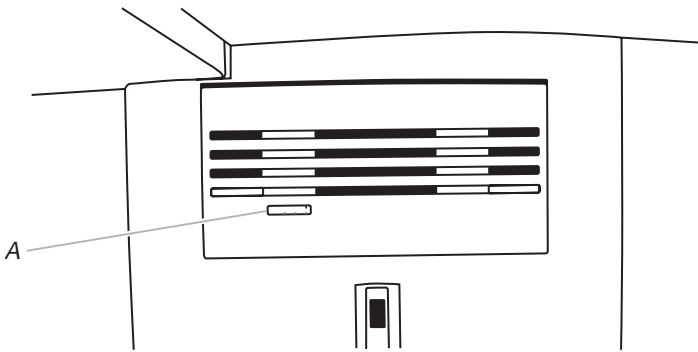

A. Status indicator window

Models without notches:

- Place the indicator somewhere it is easily visible - either inside the refrigerator, or elsewhere in your kitchen or home.

Replacing the Air Filter

The disposable air filter should be replaced every 6 months, when the status indicator has completely changed from white to red.

To order a replacement air filter, contact us. See "Accessories" for information on ordering.

1. Remove the used air filter by squeezing in on the side tabs.
2. Remove the used status indicator.
3. Install the new air filter and filter status indicator using the instructions in the previous sections.

Install Produce Preserver

The produce preserver absorbs ethylene, to slow the ripening process of many produce items. As a result, certain produce items will stay fresh longer.

Ethylene production and sensitivity varies depending on the type of fruit or vegetable. To preserve freshness, it is best to separate produce with sensitivity to ethylene from fruits that produce moderate to high amounts of ethylene.

	Sensitivity to Ethylene	Ethylene Production
Apples	High	Very High
Asparagus	Med.	Very Low
Berries	Low	Low
Broccoli	High	Very Low
Cantaloupe	Med.	High
Carrots	Low	Very Low
Citrus Fruit	Med.	Very Low
Grapes	Low	Very Low
Lettuce	High	Very Low
Pears	High	Very High
Spinach	High	Very Low

Installing the Produce Preserver

CAUTION: IRRITANT

MAY IRRITATE EYES AND SKIN. DANGEROUS FUMES FORM WHEN MIXED WITH OTHER PRODUCTS.

Do not mix with cleaning products containing ammonia, bleach or acids. Do not get in eyes, on skin or clothing. Do not breathe dust. Keep out of reach of children.

FIRST AID TREATMENT: Contains potassium permanganate. If swallowed, call a Poison Control Center or doctor immediately. Do not induce vomiting. If in eyes, rinse with water for 15 minutes. If on skin, rinse with water.

1. Find the Produce Preserver housing inside the refrigerator.

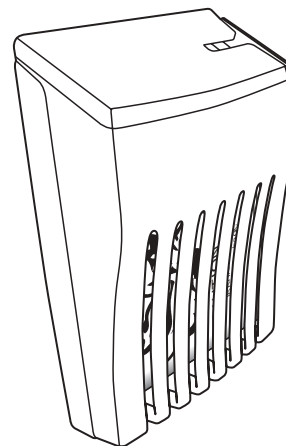

2. Open the housing by pulling up and out on the back.
3. Remove the FreshFlow™ Produce Preserver pouches from the packaging and place them into the housing.
NOTE: For best performance, always use two pouches.
4. Place the Produce Preserver housing onto the tab located on the back wall of the crisper drawer.

Installing the Status Indicator

The produce preserver comes with a status indicator, which should be activated and installed at the same time the pouches are installed.

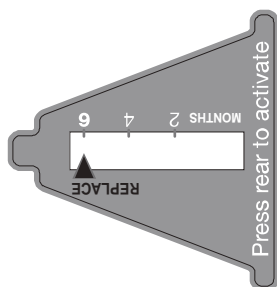

1. Place the indicator face-down on a firm, flat surface.
2. Apply pressure to the bubble on the back of the indicator until the bubble pops, to activate the indicator.

3. Slide open the cap on the top of the produce preserver housing.
4. Place the indicator in the top of the housing, facing outward.
5. Slide the cap closed, and check that the indicator is visible through the rectangular hole in the cap.

NOTE: The cap will not easily close if the indicator's bubble has not been popped.

Replacing the Produce Preserver

The disposable pouches should be replaced every 6 months or when the status indicator changes completely from white to red. To order replacements, contact us. See "Accessories" for information on ordering.

1. Remove the used pouches from the produce preserver housing.
2. Remove the used status indicator.
3. Install the replacement pouches and status indicator using the instructions in the previous sections.

Accessories

The following accessories are available for your refrigerator. To order an accessory, contact us and ask for the part number.

In the U.S.A., visit our web site www.kitchenaid.com/accessories or call 1-800-901-2042.

In Canada, visit our web site www.whirlpoolparts.ca or call 1-800-807-6777.

affresh® Stainless Steel Cleaner:

In U.S.A., order Part #W10355016

In Canada, order Part #W10355016B

affresh® Stainless Steel Wipes:

In U.S.A., order Part #W10355049

In Canada, order Part #W10355049B

affresh® Kitchen & Appliance Cleaner:

In U.S.A., order Part #W10355010

In Canada, order Part #W10355010B

Water Filter:

Order Part #W10413645A or FILTER2

Air Filter:

Order Part #W10311524 or AIR1

Produce Preserver:

Order Part # W10346771A or FRESH1

Water Filter, Air Filter and Produce Preserver Bundle Pack:

Order Part # W10413643BL

Opening and Closing Doors

There are two refrigerator compartment doors. The doors can be opened and closed either separately or together.

There is a vertically-hinged seal on the left refrigerator door.

- When the left side door is opened, the hinged seal automatically folds inward so that it is out of the way.
- When both doors are closed, the hinged seal automatically forms a seal between the two doors.

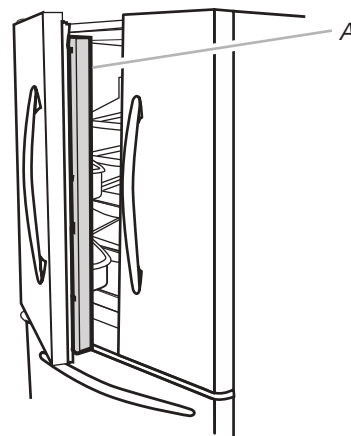

A. Hinged seal

Section 3: Controls and Operating Instructions

This section provides operational use and care information for KitchenAid, Maytag and Whirlpool Dual Evaporator French Door Refrigerators.

- Using the Controls
- Water and Ice Dispensers
- Ice Maker and Storage Bin
- Refrigerator Shelves
- Crisper and Crisper Cover
- Temperature-Controlled Drawer
- Door Bins
- Pizza Pocket and Drawer Divider
- Cleaning
- Lights
- Vacation and Moving Care

CONTROLS AND OPERATING INSTRUCTIONS

Using the Controls

The controls are located above the external dispenser.

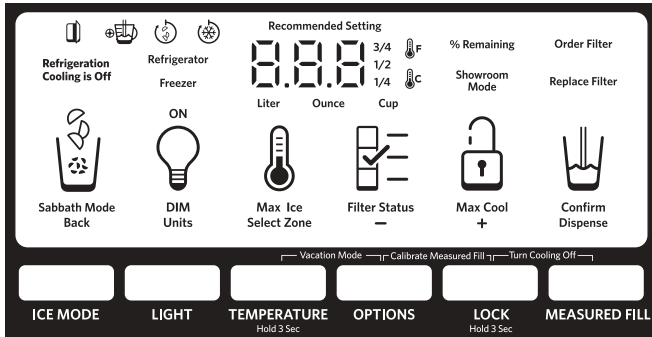

IMPORTANT: The display screen on the dispenser control panel will turn off automatically and enter “sleep” mode when the control buttons and dispenser paddles have not been used for 2 minutes or more. Press any control button to reactivate the display screen. The home screen will appear as shown.

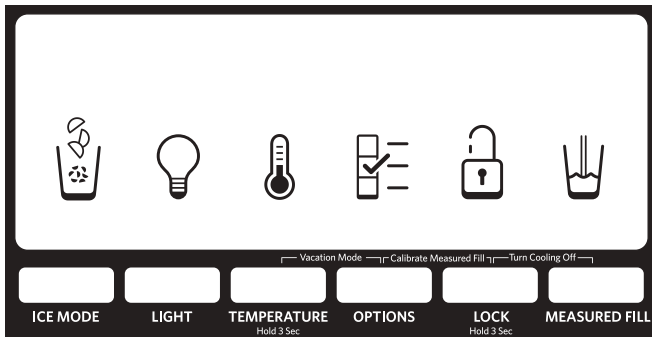

Viewing and Adjusting Temperature Set Points

For your convenience, your refrigerator and freezer temperature controls are set to the recommended set points at the factory. When you first install your refrigerator, make sure the temperature controls are still set to the recommended set points. The recommended set points are 37°F (3°C) for the refrigerator and 0°F (-18°C) for the freezer.

IMPORTANT:

- Wait 24 hours before you put food into the refrigerator. If you add food before the refrigerator has cooled completely, your food may spoil.

NOTE: Adjusting the set points to a colder than recommended setting will not cool the compartments any faster.

- If the temperature is too warm or too cold in the refrigerator or freezer, first check the air vents to be sure they are not blocked before adjusting the controls.
- The recommended set points should be correct for normal household use. The controls are set correctly when milk or juice is as cold as you like and when ice cream is firm.

NOTE: Areas such as a garage or porch, may experience hotter or colder temperatures and higher humidity than inside the home. You may need to adjust the temperature away from the recommended set points to accommodate for these conditions.

- Wait at least 24 hours between adjustments. Recheck the temperatures before other adjustments are made.

View Temperature Set Points

1. Press and hold TEMPERATURE for 3 seconds to activate Temperature mode.
2. When Temperature mode is activated, press TEMPERATURE to toggle between the Refrigerator zone and the Freezer zone. The display will show the temperature set point of the selected compartment, as shown.

NOTE: When Temperature mode is activated, to view temperatures in degrees Celsius, press the LIGHT button, under Units. To return the display setting to Fahrenheit, press the LIGHT button again.

Recommended Refrigerator Temperature

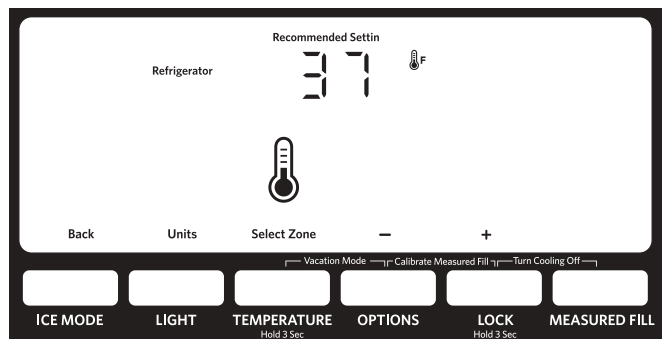

Recommended Freezer Temperature

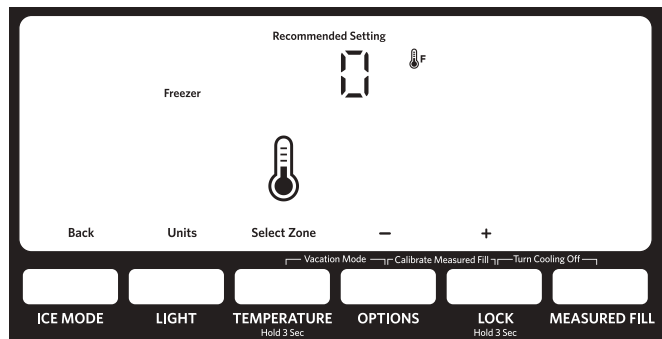

Adjust Temperature Set Points

Refrigerator set point range: 33°F to 45°F (0°C to 7°C).

Freezer set point range: -5°F to 5°F (-21°C to -15°C).

1. Press and hold TEMPERATURE for 3 seconds to activate Temperature mode.
2. When Temperature mode is activated, press TEMPERATURE to select the Refrigerator zone. The display will show the temperature set point of the selected compartment, as shown.
3. Press LOCK, under plus, to raise the set point, or press OPTIONS, under minus, to lower the set point.
4. When you have finished adjusting the refrigerator set point, press TEMPERATURE to change the display to show the freezer set point. When the zone has been changed, “FREEZER” appears on the display screen.

- Press LOCK, under plus, to raise the set point, or press OPTIONS, under minus, to lower the set point.

Save/Confirm Temperature Settings

- When you have finished adjusting both the refrigerator and freezer set points, press MEASURED FILL “Confirm” to save the settings.

NOTE: To exit Temperature mode without saving changes, press the ICE MODE button under Back at any time, or allow about 60 seconds of inactivity. The temperature mode will turn off automatically and return to the normal screen.

When adjusting temperature set points, use the following chart as a guide:

CONDITION:	TEMPERATURE ADJUSTMENT:
REFRIGERATOR too cold	REFRIGERATOR Setting 1° higher
REFRIGERATOR too warm	REFRIGERATOR Setting 1° lower
FREEZER too cold	FREEZER Setting 1° higher
FREEZER too warm / Too little ice	FREEZER Setting 1° lower

Cooling On/Off

Your refrigerator and freezer will not cool when cooling is turned off.

- To turn cooling off, press and hold the LOCK and MEASURED FILL buttons at the same time for 3 seconds. When cooling is off, “Refrigeration Cooling is Off” will appear on the display screen as shown.

IMPORTANT: To avoid unintentionally locking the dispenser or changing other settings, be sure to press both buttons at exactly the same time.

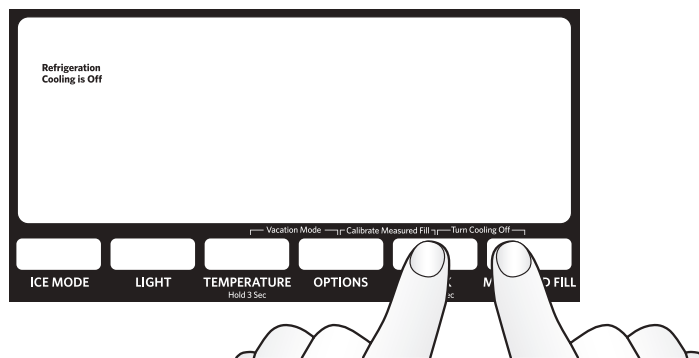

A. Press LOCK and MEASURED FILL at the same time.

- To turn cooling back on, press and hold LOCK and MEASURED FILL for 3 seconds again. “Cooling is Off” will disappear from the display screen.

Options

Press the OPTIONS button to open the Options menu and select between Max Cool, Max Ice and Water Filter Status.

Press the ICE MODE button at any time to return to the Normal screen.

Max Cool

The Max Cool feature assists with periods of high refrigerator use, full grocery loads, or temporarily warm room temperatures.

- To turn on the Max Cool feature, press the OPTIONS button to enter Options mode, then press the LOCK button, under Max Cool, to activate the feature. When the feature is on, the Max Cool icon will appear on the dispenser display screen. The Max Cool feature will remain on for 24 hours unless manually turned off.



- To manually turn off the Max Cool feature, press the OPTIONS button to enter Options mode (unless you are already in Options mode), then press LOCK again. When the feature has been turned off, the Max Cool icon will disappear from the dispenser display.
- NOTE:** Setting the freezer to a colder temperature may make some foods, such as ice cream, harder.

Max Ice

The Max Ice feature assists with temporary periods of heavy ice use by increasing ice production.

- To turn on the Max Ice feature, press the OPTIONS button to enter Options mode, then press the TEMPERATURE button, under Max Ice, to activate the feature. When the feature is on, the Max Ice icon will appear on the dispenser display screen. The Max Ice feature will remain on for 24 hours unless manually turned off.



- To manually turn off the Max Ice feature, press the OPTIONS button to enter Options mode (unless you are already in Options mode), then press TEMPERATURE again. When the feature has been turned off, the Max Ice icon will disappear from the dispenser display.

Water Filter Status

Press FILTER STATUS to display the percentage of use remaining in the water filter (from 100% to 0%).

ALSO

The water filter status lights will let you know when to change your water filter.

- ORDER FILTER (Yellow)** - Order a replacement water filter.
- REPLACE FILTER (Red)** - Replace the water filter. Replacing the disposable water filter will automatically reset the water filter status tracking feature. See “Water Filtration System.”

CONTROLS AND OPERATING INSTRUCTIONS

NOTE: REPLACE FILTER will remain illuminated if a filter is not installed or installed incorrectly.

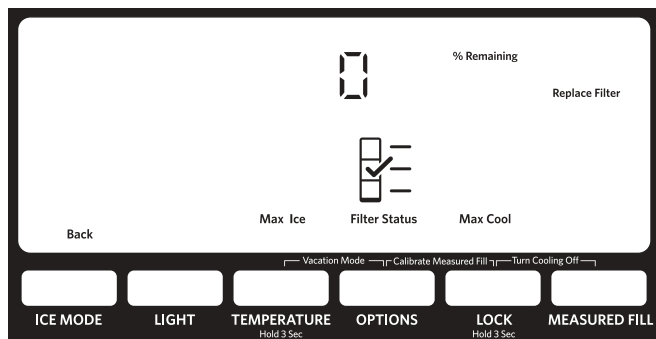

Additional Features

Sabbath Mode

Sabbath Mode is designed for those whose religious observances require turning off the lights and dispensers.

In Sabbath Mode, the temperature set points remain unchanged, but the interior and dispenser lights turn off, all sounds and alarms, and the dispenser paddles are disabled.

- To turn on Sabbath Mode, press and hold LIGHT and OPTIONS at the same time for 3 seconds. When the feature turns on, “Sabbath Mode” will appear on the dispenser display.
- To turn off Sabbath Mode, press and hold LIGHT and OPTIONS, at the same time, for 3 seconds. The screen will display the settings as they were before Sabbath Mode was turned on. However, the Max Cool and Max Ice features, will remain off until they are selected again.

NOTES:

- Turning “Cooling Off” will cancel Sabbath Mode
- If a power outage occurs while in Sabbath Mode, Power Outage will not be indicated on the display no matter how long the power was out.

Vacation Mode

In Vacation Mode, the freezer will defrost less often to conserve energy.

- To turn on Vacation Mode, press and hold TEMPERATURE and OPTIONS at the same time for 3 seconds. When the feature turns on, “VAC” will appear on the dispenser display.
- To turn off Vacation Mode, press and hold TEMPERATURE and OPTIONS at the same time, again, for 3 seconds. The screen will display the settings as they were before Vacation Mode was turned on.

NOTES:

- During the first hour after Vacation Mode is turned on, opening and closing the refrigerator door will not affect the setting. After 1 hour has passed, opening and closing the refrigerator door will turn off Vacation Mode.
- While in Vacation Mode, if Max Ice, Max Cool or Sabbath Mode is turned on, it will cancel Vacation Mode.

Power Outage Indicator

The power outage indicator lets you know if the power supply to the refrigerator has been cut off and the freezer temperature has risen to 18°F (-8°C) or higher.

When power has been restored, “PO” repeatedly flashes on the control panel display. All other control and dispenser functions are disabled and “PO” will continue to blink until you acknowledge the power outage.

- Press the MEASURED FILL button to confirm. The Power Outage icon “PO” will disappear, and the control panel will return to the Normal screen.

Door Ajar Alarm

The Door Ajar Alarm feature sounds an alarm when the refrigerator door(s) or freezer drawer is open for 5 minutes and cooling is turned on. The alarm will repeat every 2 minutes. Close all doors and drawer to turn it off. The feature then resets and will reactivate when either door is left open again for 5 minutes.

NOTE: To mute the audible alarm while keeping the doors open, such as while cleaning the inside of the refrigerator, press any button on the control panel. The alarm sound will be temporarily turned off, but the Door Ajar icon will still be displayed on the dispenser control panel.



Disabling Sounds

- To turn off control and dispenser sounds, press and hold ICE MODE and MEASURED FILL at the same time for 3 seconds. All normal operating tones are disabled. Only alert tones will be audible.
- To turn all sounds back on, press and hold ICE and MEASURED FILL at the same time for 3 seconds again.

Showroom Mode

This mode is used only when the refrigerator is on display in a retail store. If you unintentionally turn on Showroom mode, the words “Showroom Mode” will light up on the display. Exit Showroom mode by pressing and holding LIGHT and LOCK at the same time for 3 seconds.

Water and Ice Dispensers

IMPORTANT:

- Allow 3 hours for the refrigerator to cool down and chill water.
- Allow 24 hours to produce the first batch of ice. Discard the first three batches of ice produced.
- The dispensing system will not operate when either the refrigerator door or freezer drawer is open.

Flush the Water System

Air in the water dispensing system can cause the water dispenser to drip. After connecting the refrigerator to a water source or replacing the water filter, flush the water system.

Flushing the water dispensing system, forces air from the water line and filter and prepares the water filter for use. Additional flushing may be required in some households.

NOTE: As air is cleared from the system, water may spurt out of the dispenser.

1. Using a sturdy container, depress and hold the water dispenser paddle for 5 seconds.
2. Release the dispenser paddle for 5 seconds. Repeat steps 1 and 2 until water begins to flow.
3. Once water begins to flow, continue depressing and releasing the dispenser pad (5 seconds on, 5 seconds off) until a total of 3 gal. (12 L) has been dispensed.

Calibrate Measured Fill

Household water pressure may affect the accuracy of the Measured Fill feature. So, for optimum performance of your water dispenser, you must first calibrate Measured Fill.

IMPORTANT: Flush the water system before calibrating Measured Fill.

1. Place a sturdy measuring cup (1 cup [237 mL] size) on the dispenser tray centered in front of the water dispenser paddle.

NOTE: Depending on your model, a measuring cup may be provided.

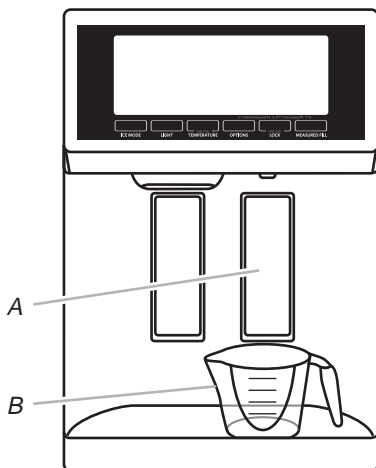

A. Water dispenser paddle
B. Measuring cup (1 cup)

2. Press and hold the OPTIONS and LOCK buttons at the same time for 3 seconds. The words “Back” and “1 Cup” will appear on the display screen. Also, the Calibrate Measured Fill icon will illuminate and remain lit while the Measured Fill feature is being calibrated.



NOTE: You may press ICE MODE “Back” at any time to exit calibration mode. The Calibrate Measured Fill icon will turn off.

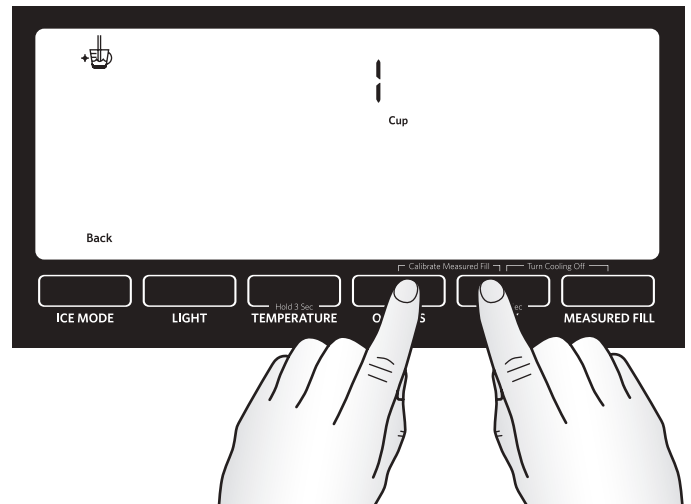

3. Press and release the water dispenser paddle, as needed, to dispense water to the 1 cup fill line.

NOTE: If overfilling or spilling occurs, discard the water and press ICE MODE “Back” to restart the calibration process.

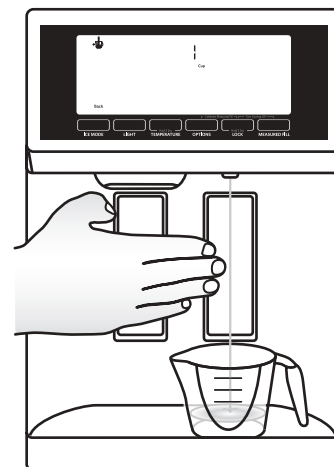

CONTROLS AND OPERATING INSTRUCTIONS

- When 1 cup of water has been correctly dispensed into the measuring cup, press the MEASURED FILL button under the word “Confirm” to confirm the calibration.

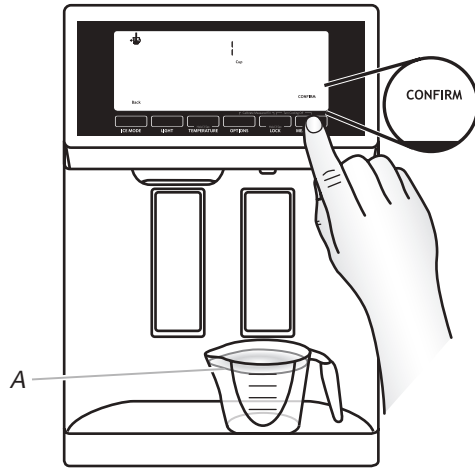

A. 1 cup of water

- When Measured Fill calibration has been confirmed the icons will disappear and the display will return to the home screen.

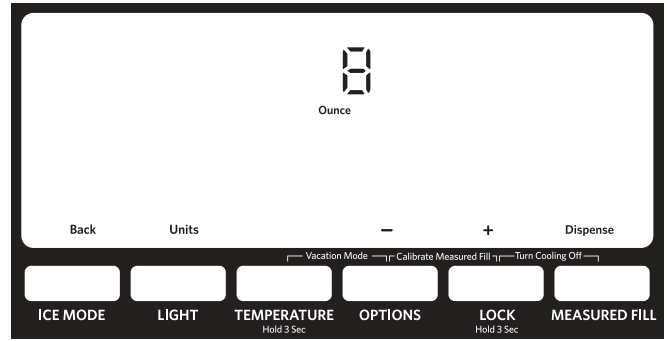

Press ICE MODE, under Back, to manually turn off the Measured Fill feature and return to the home screen.

NOTE: The dispenser will automatically turn off Measured Fill after 1 minute of inactivity. When Measured Fill is turned off, any changes you have made will be lost and all defaults will be restored.

- You can dispense water by the ounce, cup, or liter. The default unit is ounces. To switch to cups or liters, press the LIGHT button under Units.

Default, minimum, and maximum volumes are listed in the following chart:

Units	Default	Minimum	Maximum
Ounces	8	1	128
Cups	1	1/4	16
Liters	0.25	0.05	4.00

- Press the LOCK (+) and OPTIONS (-) buttons to adjust the volume as desired. The LOCK button increases the volume, and the OPTIONS button lowers the volume.

NOTES:

- When increasing or decreasing the dispense volumes, if an adjustment button (-/+) is held for approximately 10 seconds or longer the control may stop responding. Release the button for approximately 2 seconds and then continue making the adjustment.
- Most coffee cups (commonly 4 to 6 oz [118 to 177 mL] per cup) are not the same size as a measuring cup (8 oz [237 mL]). You may need to adjust the volume to avoid unintentionally overfilling coffee cups.

- To dispense water, press a sturdy glass against the water dispenser lever OR place the glass below the water dispenser and press the MEASURED FILL button.

NOTE: While dispensing water, the digital display will count down how much water remains to be dispensed, according to the volume you selected. The flow of water will automatically stop once the desired volume has been dispensed.

- To stop dispensing before the selected volume has been dispensed, remove the glass from the dispenser lever OR press the MEASURED FILL button a second time.

NOTE: If you stop dispensing before the desired volume has been dispensed, the digital display will continue to show how much water remains to be dispensed. The display will turn off after 1 minute of inactivity.

- To select a new volume or start dispensing the same volume again, you must first finish dispensing the selected volume, or turn off the Measured Fill feature (either by waiting 1 minute so it will automatically turn off or by pressing ICE MODE to manually turn it off) and then turn it back on.

The Water Dispenser

IMPORTANT:

- Dispense at least 1 qt (1 L) of water every week to maintain a fresh supply.
- If the flow of water from the dispenser decreases, it could be caused by low water pressure.
 - With the water filter removed, dispense 1 cup (237 mL) of water. If 1 cup (237 mL) of water is dispensed in 8 seconds or less, the water pressure to the refrigerator meets the minimum requirement.
 - If it takes longer than 8 seconds to dispense 1 cup (237 mL) of water, the water pressure to the refrigerator is lower than recommended. See “Water Supply Requirements” and “Troubleshooting” for suggestions.

To Dispense Water - Standard:

- Press a sturdy glass against the dispenser paddle.
- Remove the glass to stop dispensing

To Dispense Water - Measured Fill:

Measured Fill allows you to dispense a specified amount of water with the touch of a few buttons.

NOTE: The amount of water you select will be dispensed. Make sure the container is empty and that it can hold the entire volume. If ice is in the container, you may need to adjust your selection.

- Press MEASURED FILL to turn the feature on. When the feature is on, the Measured Fill screen appears on the display.

The Ice Dispenser

Ice dispenses from the ice maker storage bin. To turn off the ice maker, see “Ice Maker and Storage Bin.”

The dispenser may continue to make noise and ice may continue to dispense for several seconds after releasing the dispenser button or paddle.

IMPORTANT: If the ice cubes are hollow or have an irregular shape, it could be because of low water pressure. See “Water Supply Requirements.”

To Clean the Ice Dispenser Chute:

Humidity causes ice to naturally clump together. Ice particles can build up until the ice dispenser chute becomes blocked.

If ice is not dispensed regularly, it may be necessary to empty the ice storage bin and clean the ice delivery chute, the ice storage bin and the area beneath the storage bin every 2 weeks.

- If necessary, remove the ice clogging the storage bin and delivery chute, using a plastic utensil.
- Clean the ice delivery chute and the bottom of the ice storage bin using a warm, damp cloth and dry thoroughly.

To Dispense Ice:

⚠ WARNING



Cut Hazard

Use a sturdy glass when dispensing ice.

Failure to do so can result in cuts.

IMPORTANT: You do not need to apply a lot of pressure to the paddle to activate the ice dispenser. Pressing hard will not make the ice dispense faster or in greater quantities.

1. Press ICE MODE to select cubed ice (default) or crushed ice. The display screen indicates which type of ice is selected.

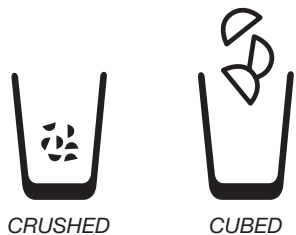

2. Press a sturdy glass against the dispenser paddle. Remove the glass to stop dispensing. Hold the glass close to the dispenser opening so ice does not fall outside of the glass.

NOTE: When changing from crushed to cubed, a few ounces of crushed ice will be dispensed along with the first cubes.

The Dispenser Drip Tray

There is an insert in the dispenser drip tray. The insert can be removed from the drip tray to carry to the sink to empty or clean.

- Push down on the rear edge of the insert to tilt up the front edge for easy removal.

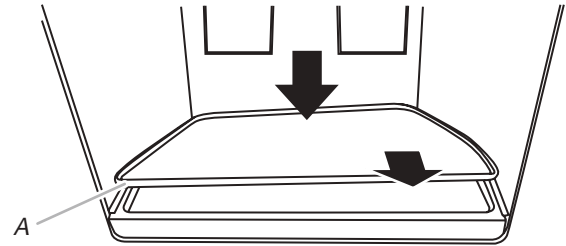

A. Dispenser tray insert

The Dispenser Light

When you use the dispenser, the light will automatically turn on.

To turn on the light when you are not dispensing:

Press LIGHT to toggle through the following choices in a continuous loop:

- OFF (default): The dispenser light is off.
- ON: The dispenser light is on at 100% brightness
- DIM: The dispenser light is on at 50% brightness

The dispenser lights are LEDs that cannot be changed. If it appears that your dispenser lights are not working, see “Troubleshooting” for more information.



The Dispenser Lock

The dispenser can be disabled for easy cleaning or to avoid unintentional dispensing by small children and pets.

NOTE: The lock feature does not shut off power to the refrigerator, to the ice maker, or to the dispenser light. It simply deactivates the controls and dispenser levers. To turn off the ice maker, see “Ice Maker and Storage Bin.”

- Press and hold LOCK for 3 seconds to lock the dispenser.
- Press and hold LOCK for 3 seconds to unlock the dispenser.

The display screen indicates when the dispenser is locked.



CONTROLS AND OPERATING INSTRUCTIONS

Ice Maker and Ice Storage Bin

IMPORTANT: To avoid low ice production and poor quality ice, flush the water system before turning on the ice maker. See “Water Dispenser.”

- Allow 24 hours to produce the first batch of ice. Discard the first three batches of ice produced. Allow 2 to 3 days for the storage bin to fill completely following installation.
- The quality of your ice will be only as good as the quality of the water supplied to your ice maker. Avoid connecting the ice maker to a softened water supply. Water softener chemicals (such as salt) can damage parts of the ice maker and lead to poor quality ice. If a softened water supply cannot be avoided, make sure the water softener is operating properly and is well maintained.
- If the ice in the storage bin clumps together, break up ice using a plastic utensil and discard. Do not use anything sharp to break up the ice. This can cause damage to the ice bin and the dispenser mechanism.
- Do not store anything in the ice storage bin.

Ice Production Rate

- The ice maker should produce approximately 3 lbs (1.4 kg) of ice per day under normal operation.
- To increase ice production, select the increased ice production feature from the Options menu on the control panel. See “Using the Control(s).”

Style I - Ice Maker in the Refrigerator (on some models)

The ice maker is located on the left-hand side of the refrigerator compartment ceiling. Ice cubes are ejected into the ice storage bin, located on the left-hand refrigerator door.

Turn the Ice Maker On/Off

1. Push up on the latch on the left-hand side of the ice compartment to open the door.

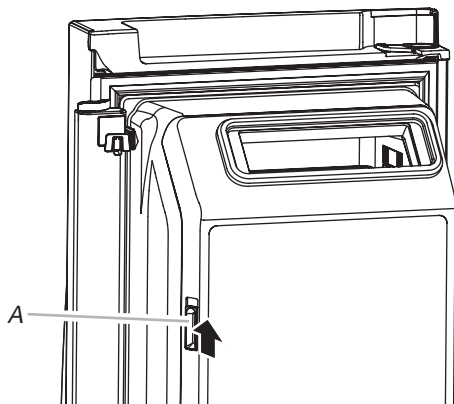

A. Ice compartment door latch

2. Turn on the ice maker by moving the switch to the (left) ON position.

NOTES:

- To manually turn off the ice maker, move the control to the OFF (right) position.

- Your ice maker has an automatic shutoff. The sensor will automatically stop ice production if the storage bin is full, if the door is open or the storage bin is removed. The control will remain in the ON (left) position.

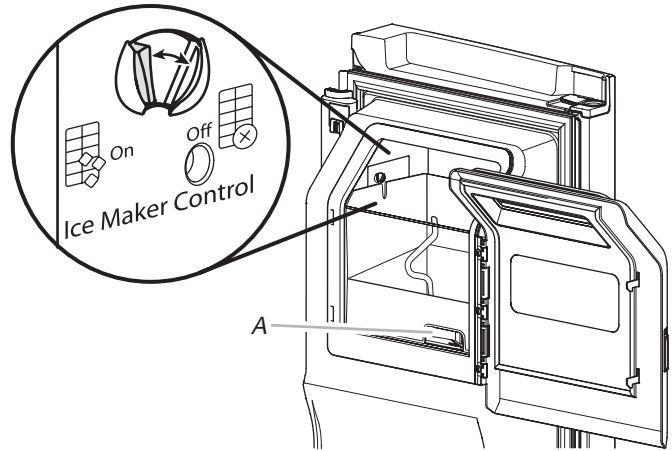

A. Ice storage bin release latch

3. Close the ice compartment door.

Remove and Replace the Ice Storage Bin

- Remove the ice storage bin by inserting your fingers into the hole at the base of the bin and squeezing the latch to release the bin from the compartment. Lift the storage bin up and pull it straight out.
- Replace the storage bin inside the ice compartment and push down to make sure it is firmly in place.

Important information to know about glass shelves and covers:

Do not clean glass shelves or covers with warm water when they are cold. Shelves and covers may break if exposed to sudden temperature changes or impact, such as bumping. Tempered glass is designed to shatter into many small, pebble-size pieces. This is normal. Glass shelves and covers are heavy. Use both hands when removing them to avoid dropping.

Refrigerator Shelves

The shelves in your refrigerator are adjustable to meet your individual storage needs.

Storing similar food items together in your refrigerator and adjusting the shelves to fit different heights of items will make finding the exact item you want easier. It will also reduce the amount of time the refrigerator door is open, and save energy.

Shelves and Shelf Frames

To remove and replace a shelf/shelf frame:

1. Remove the shelf/frame by tilting it up at the front and lifting it out of the shelf supports.
2. Replace the shelf/frame by guiding the rear shelf hooks into the shelf supports. Tilt the front of the shelf up until rear shelf hooks drop into the shelf supports.
3. Lower the front of the shelf and make sure that the shelf is in position.

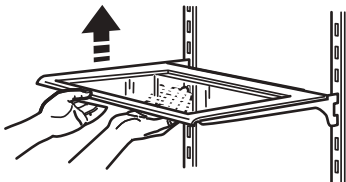

Tuck Away Shelf

To remove and replace a shelf/shelf frame:

1. Remove the shelf/frame by tilting it up at the front and lifting it out of the shelf supports.
2. Replace the shelf/frame by guiding the rear shelf hooks into the shelf supports. Tilt the front of the shelf up until rear shelf hooks drop into the shelf supports.
3. Lower the front of the shelf and make sure that the shelf is in position.

To retract and extend the front section of the shelf:

1. To retract the front-section of the shelf, slightly lift up on the front edge and push the adjustable portion of the shelf back toward the rear of the refrigerator.
2. Extend the front of the shelf by pulling the retracted portion of the shelf outward until it is fully extended.

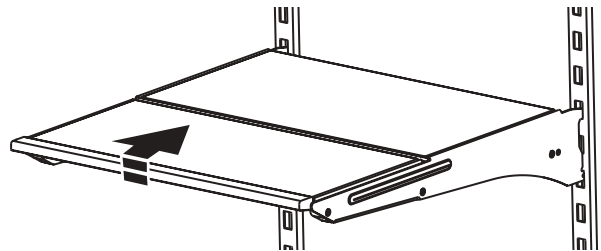

CONTROLS AND OPERATING INSTRUCTIONS

Crisper and Crisper Cover

The humidity level in the crisper drawers is automatically regulated, so there is no humidity control.

To remove and replace a crisper drawer:

1. Remove the drawer by pulling it open halfway. Then, lift up on the drawer to remove it completely.

NOTE: If you unintentionally pull open the drawer to the drawer stop, it will lock in place and you will not be able to lift the drawer up and out.

2. Replace a drawer by placing it on the slide rails and pushing it back into position past the drawer stop.

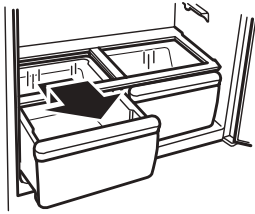

To remove the crisper(s) cover:

1. Remove crisper(s).
2. Holding the glass insert firmly with one hand, press up in center of glass insert until it rises above the plastic frame. Gently slide the glass insert forward to remove.
3. Lift the cover frame up and remove it.

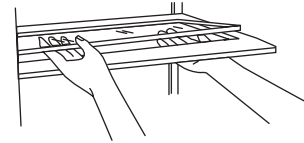

To replace crisper(s) cover:

1. Fit back of cover frame into supports on side walls of the refrigerator and lower the front of the cover frame into place.
2. Slide rear of glass insert into cover frame and lower front into place.

Temperature-Controlled Drawer (on some models)

The full-width, temperature-controlled drawer can be used to store large deli trays, fresh meat, beverages or other items that you want to store at a specific temperature.

NOTE: Do not place leafy vegetables in the temperature-controlled drawer. Colder temperatures could damage leafy produce.

Preset Temperature Control

IMPORTANT: The control is for this drawer only. It will not affect the temperature of, or turn off cooling to the refrigerator or freezer compartments.

For your convenience, temperatures have been preset for the optimum storage of fresh meat, party trays, deli and wine.

Press PRESET to toggle among the following four temperature settings. Each icon will light up, in turn, and the preset temperature will display:

- Fresh Meat - 32°F (0°C)
- Party - 36°F (2°C)
- Deli (default setting) - 39°F (4°C)
- Wine - 41°F (5°C)

NOTE: If no button is pressed, the control will revert to Deli, the default setting as shown.

Custom Temperature Control

Allows you to select the optimum temperature, within the temperature range of the drawer, for your storage needs.

The temperature range for the drawer is 32°F (0°C) to 41°F (5°C).

- Press (+) or (-) to increase or decrease the temperature by 1 degree.

NOTES:

- If you adjust the temperature to a non-preset temperature, the word “custom” will light up. If you adjust the temperature to a preset temperature, the preset food icon will light up.
- If you try to select a temperature outside the temperature range of the drawer, the temperature display will not change.

Drawer Removal and Replacement

To remove the drawer:

1. Push the drawer completely closed.
2. Lift up the front of the drawer and pull it straight out.

To replace the drawer:

1. Push the metal glide rails to the rear of the refrigerator.
2. Place the drawer onto the glide rails. While tilting the rear of the drawer upward, slide the drawer toward the rear of the refrigerator.



CONTROLS AND OPERATING INSTRUCTIONS

Drawer Divider

To remove the divider:

1. Pull the drawer out to its full extension.
2. Lift the front of the divider and lift the divider out.

To replace the divider:

1. Position the divider so that the features on the bottom of the divider align with the matching features in the drawer.
2. Lower the divider into place.

Meat Storage Guide

Store most meat in original wrapping as long as it is airtight and moisture-proof. Rewrap if necessary. See the following chart for storage times. When storing meat longer than the times given, freeze the meat.

Fresh fish or shellfish.....use same day as purchased
Chicken, ground beef, variety meats (liver) 1-2 days
Cold cuts, steaks/roasts3-5 days
Cured meats7-10 days
Leftovers - Cover leftovers with plastic wrap, aluminum foil, or plastic containers with tight lids.

Door Bins

To remove and replace the bins:

1. Remove the bin by lifting it up and pulling it straight out.
2. Replace the bin by sliding it in above the desired support and pushing it down until it stops.

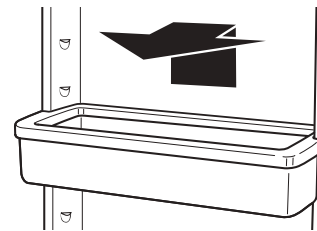

Pizza Pocket and Drawer Divider

The drawer divider is not removable. For storage flexibility, the divider can be moved a few inches to either side allowing you to store larger items in one section of the freezer drawer.

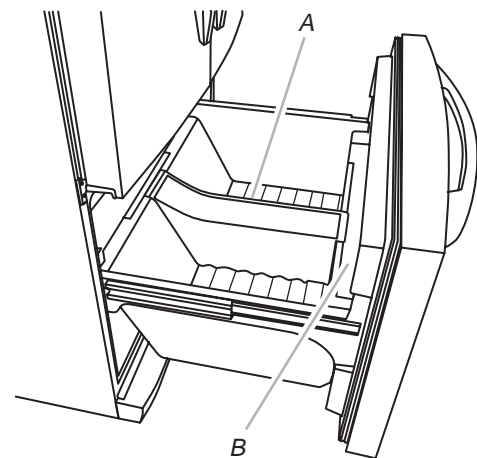

A. Drawer divider
B. Pizza pocket

CONTROLS AND OPERATING INSTRUCTIONS

Cleaning

⚠ WARNING



Explosion Hazard
Use nonflammable cleaner.
Failure to do so can result in death, explosion, or fire.

Both the refrigerator and freezer sections defrost automatically. However, clean both sections about once a month to avoid buildup of odors. Wipe up spills immediately.

Exterior Cleaning

Please see the exterior cleaning information specific to your model.

Style I - Smooth Door

IMPORTANT: Damage to smooth finish due to improper use of cleaning products, or using non-recommended cleaning products, is not covered under the warranty. Sharp or blunt instruments will mar the finish.

DO USE	DO NOT USE
<ul style="list-style-type: none"> ✓ Soft, clean cloth 	<ul style="list-style-type: none"> ✗ Abrasive cloths ✗ Paper towels or newsprint ✗ Steel-wool pads
<ul style="list-style-type: none"> ✓ Warm, soapy water - use a mild detergent 	<ul style="list-style-type: none"> ✗ Abrasive powders or liquids ✗ Window sprays ✗ Ammonia ✗ Acidic or vinegar based cleaners ✗ Oven cleaners ✗ Flammable fluids

NOTE: Paper towels scratch and may dull the clear coat of the painted door. To avoid possible damage use only soft clean clothes to polish and wipe the door.

Style 2 - Stainless Steel

IMPORTANT:

- Damage to stainless steel finish due to improper use of cleaning products, or using non-recommended cleaning products, is not covered under the warranty.

DO USE	DO NOT USE
<ul style="list-style-type: none"> ✓ Soft, clean cloth 	<ul style="list-style-type: none"> ✗ Abrasive cloths ✗ Paper towels or newsprint ✗ Steel-wool pads
<ul style="list-style-type: none"> ✓ Warm, soapy water 	<ul style="list-style-type: none"> ✗ Abrasive powders or liquids ✗ Ammonia ✗ Citrus-based cleaners ✗ Acidic or vinegar-based cleaners ✗ Oven cleaners
<ul style="list-style-type: none"> ✓ For heavy soil, ONLY a stainless steel cleaner designed for appliances. To order the cleaner, see "Accessories." 	<ul style="list-style-type: none"> ✗ Stainless steel cleaner is for stainless steel parts only! Do not allow the Stainless Steel Cleaner and Polish to come into contact with any plastic parts such as the trim pieces, dispenser covers or door gaskets.

NOTES:

- If unintentional contact does occur, clean plastic part with a sponge and mild detergent in warm water. Dry thoroughly with a soft cloth.
- Just because a cleaner is a liquid does not mean it is nonabrasive. Many liquid cleansers formulated to be gentle on tile and smooth surfaces still damage stainless steel.
- Citric acid permanently discolors stainless steel. To avoid damaging the finish of your stainless steel refrigerator:

Do not allow these substances to remain on the finish

- | | |
|------------------|-------------------------|
| ✗ Mustard | ✗ Citrus-based sauces |
| ✗ Tomato juice | ✗ Citrus-based products |
| ✗ Marinara sauce | |

Interior Cleaning

1. Unplug refrigerator or disconnect power.
2. Hand wash, rinse, and dry removable parts and interior surfaces thoroughly. Use a clean sponge or soft cloth and a mild detergent in warm water.

NOTE: Do not use abrasive or harsh cleaners such as window sprays, scouring cleansers, flammable fluids, cleaning waxes, concentrated detergents, bleaches or cleansers containing petroleum products on plastic parts, interior and door liners or gaskets.

3. Plug in refrigerator or reconnect power.

Condenser Cleaning

There is no need for routine condenser cleaning in normal home operating environments. If the environment is particularly greasy or dusty, or there is significant pet traffic in the home, the condenser should be cleaned every 2 to 3 months to ensure maximum efficiency.

If you need to clean the condenser:

1. Unplug refrigerator or disconnect power.
2. Remove the base grille.
3. Use a vacuum cleaner with a soft brush to clean the grille, the open areas behind the grille and the front surface area of the condenser.
4. Replace the base grille when finished.
5. Plug in refrigerator or reconnect power.

Lights

The lights in both the refrigerator and freezer compartments are LEDs which do not need to be replaced. If the lights do not illuminate when the door or drawer is opened, call for assistance or service. In the U.S.A., call **1-800-253-1301**. In Canada call **1-800-807-6777**.

Vacation and Moving Care

Vacations

If You Choose to Leave the Refrigerator On While You're Away:

1. Use up any perishables and freeze other items.
2. If your refrigerator has an automatic ice maker, and is connected to the household water supply, turn off the water supply to the refrigerator. Property damage can occur if the water supply is not turned off.
3. If you have an automatic ice maker, turn off the ice maker.
NOTE: Depending on your model, raise the wire shutoff arm to OFF (up) position, or press the switch to OFF.
4. Empty the ice bin.

If You Choose to Turn Off the Refrigerator Before You Leave:

1. Remove all food from the refrigerator.
2. If your refrigerator has an automatic ice maker:
 - Turn off the water supply to the ice maker at least one day ahead of time.
 - When the last load of ice drops, raise the wire shutoff arm to the OFF (up) position or press the switch to OFF, depending on your model.
3. Turn off the Temperature control(s). See "Using the Control(s)."
4. Clean refrigerator, wipe it, and dry well.
5. Tape rubber or wood blocks to the tops of both doors to prop them open far enough for air to get in. This stops odor and mold from building up.

Moving

When you are moving your refrigerator to a new home, follow these steps to prepare it for the move.

1. If your refrigerator has an automatic ice maker:
 - Turn off the water supply to the ice maker at least one day ahead of time.
 - Disconnect the water line from the back of the refrigerator.
 - When the last load of ice drops, raise the wire shutoff arm to the OFF (up) position or press the switch to OFF, depending on your model.
2. Remove all food from the refrigerator and pack all frozen food in dry ice.
3. Empty the ice bin.
4. Turn off the Temperature control(s). See "Using the Control(s)."
5. Unplug refrigerator.
6. Clean, wipe, and dry thoroughly.
7. Take out all removable parts, wrap them well, and tape them together so they don't shift and rattle during the move.
8. Depending on the model, raise the front of the refrigerator so it rolls more easily OR raise the leveling screws so they don't scrape the floor. See "Adjust the Door(s)."
9. Tape the doors closed and tape the power cord to the back of the refrigerator.

When you get to your new home, put everything back and refer to the "Installation Instructions" section for preparation instructions. Also, if your refrigerator has an automatic ice maker, remember to reconnect the water supply to the refrigerator.

Section 4: Theory of Operation

This section provides general information concerning the theory of operation for KitchenAid, Maytag and Whirlpool Dual Evaporator French Door Refrigerators.

- XXL French Door Bottom Mount Cut Away
- High Side Assembly
- Dual Evaporator Refrigerant System
- Cooling Operation - Pull Down
- Cooling Operation - Normal Cooling

THEORY OF OPERATION

XXL French Door Bottom Mount Cut Away

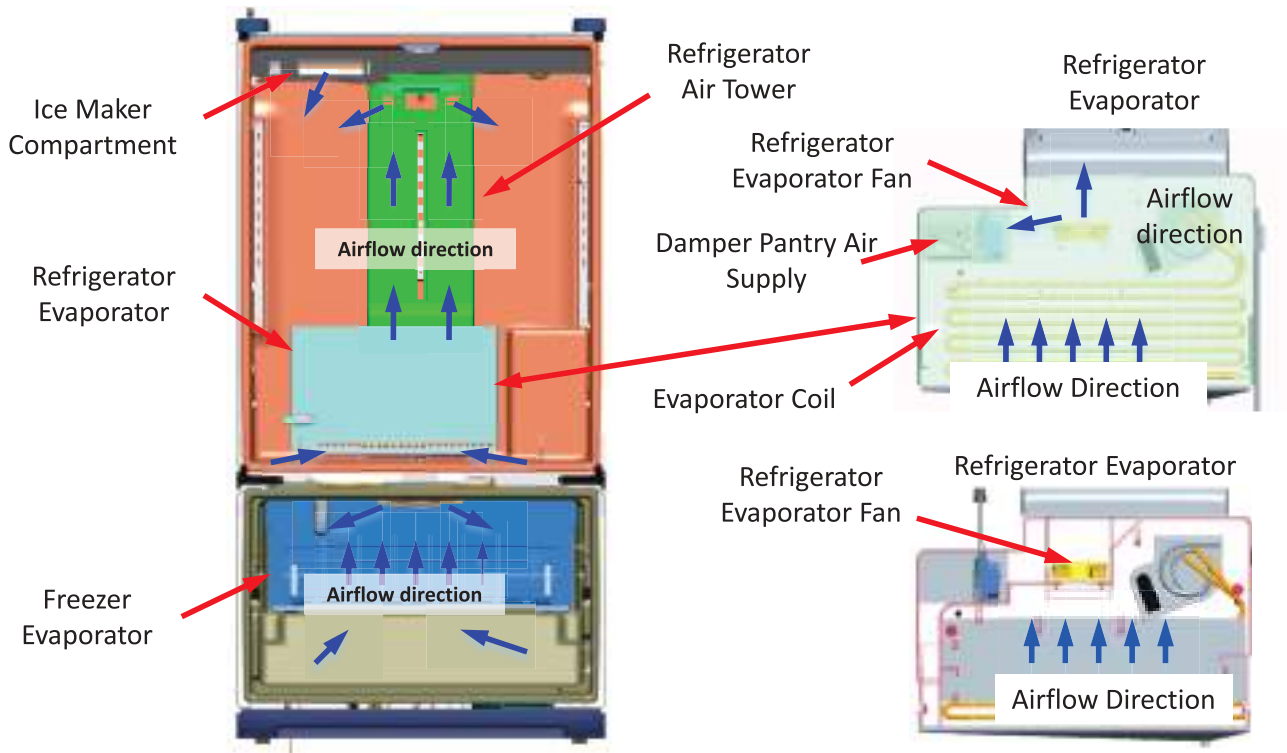
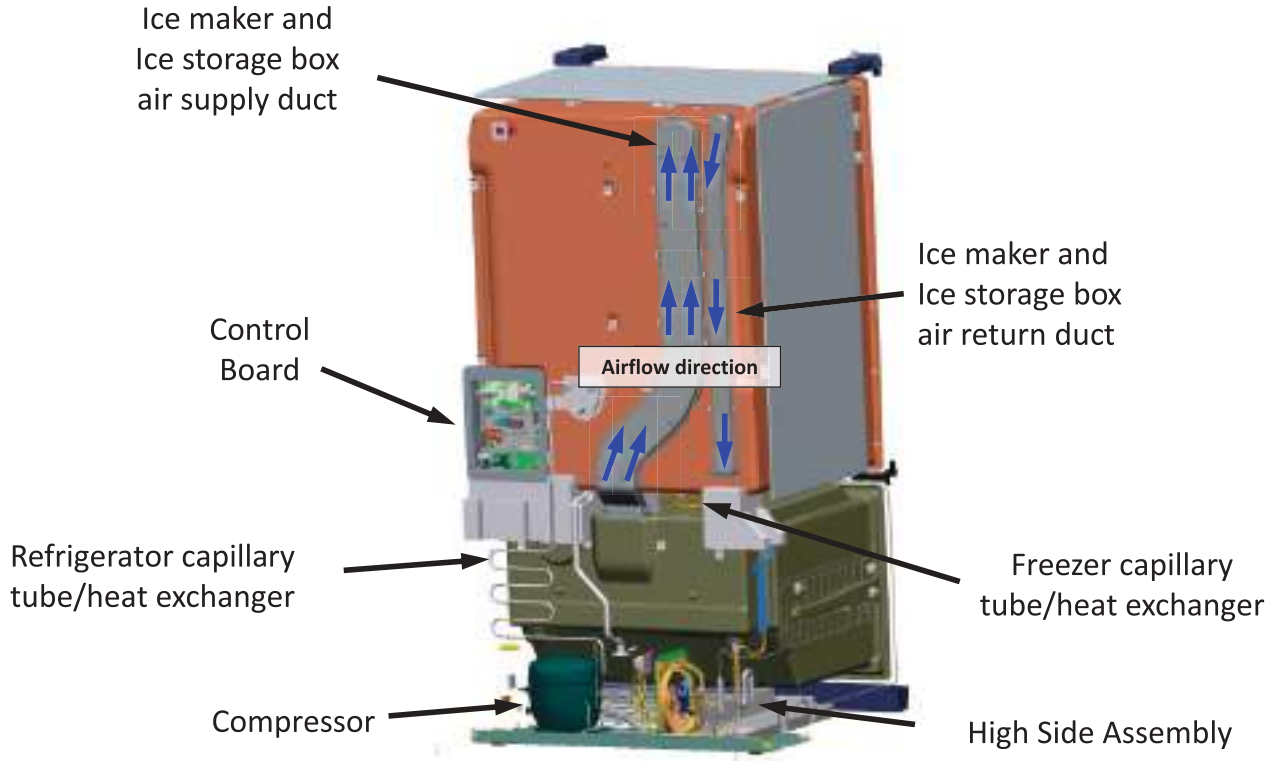

High Side Assembly

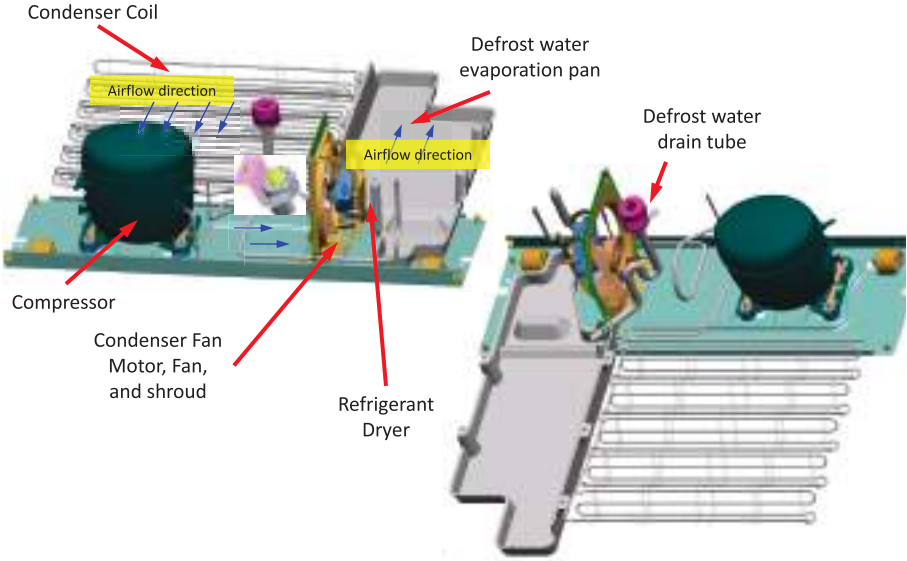

Notes

Dual Evaporator Refrigerant System

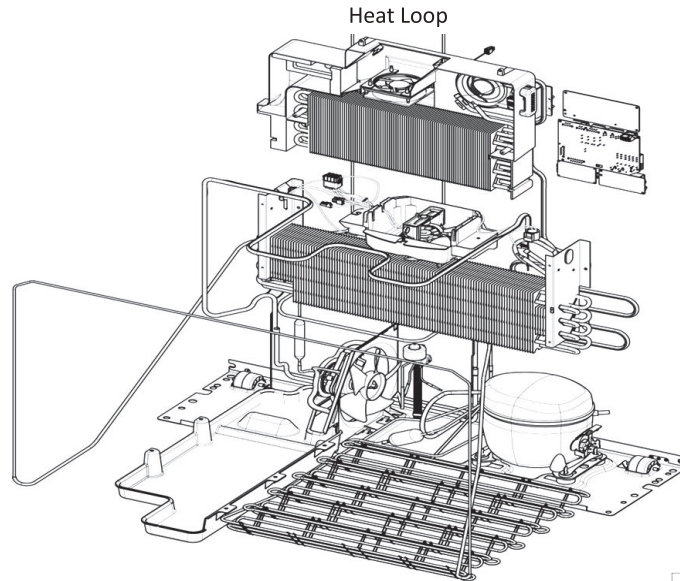

Refrigeration system is called a sequential dual evaporator system.

- Uniqueness
 - Two separate evaporator coils and capillary tubes
 - One for the refrigerator
 - One for the freezer
 - A 3 way valve is used to direct refrigerant flow to either the refrigerator or freezer evaporator coil depending on the compartment in need of cooling.
 - Refrigerant flow is only directed through one evaporator at a time and therefore the use of the word sequential cooling.

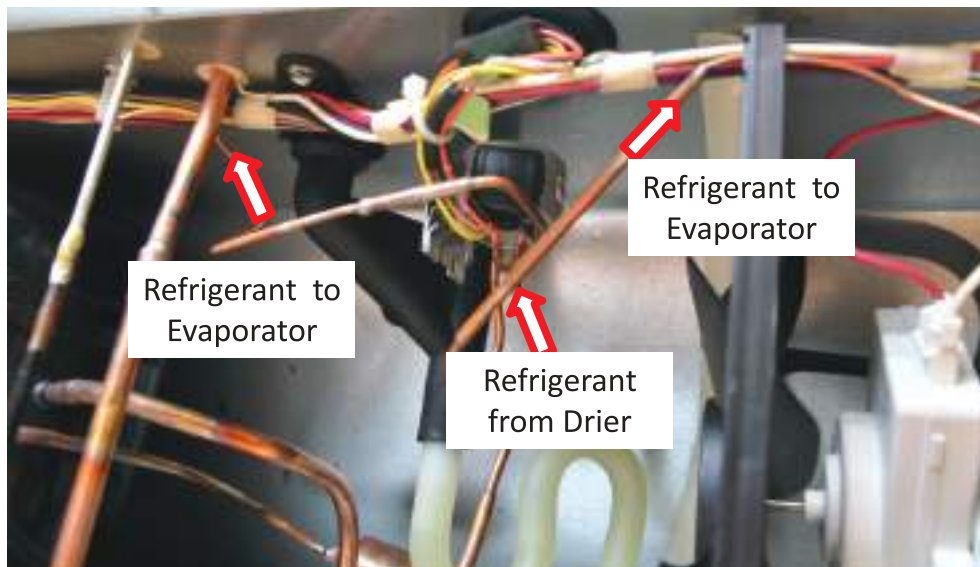

RKV 3-Way Rotary Valve

Dual Evaporator Refrigerant System (cont.)

Machine Compartment

The components located in the machine compartment have been used on previously manufactured bottom freezer refrigerators with these exceptions:

- 3 way refrigeration valve.
- Refrigerant check valve.
- Noise mufflers.

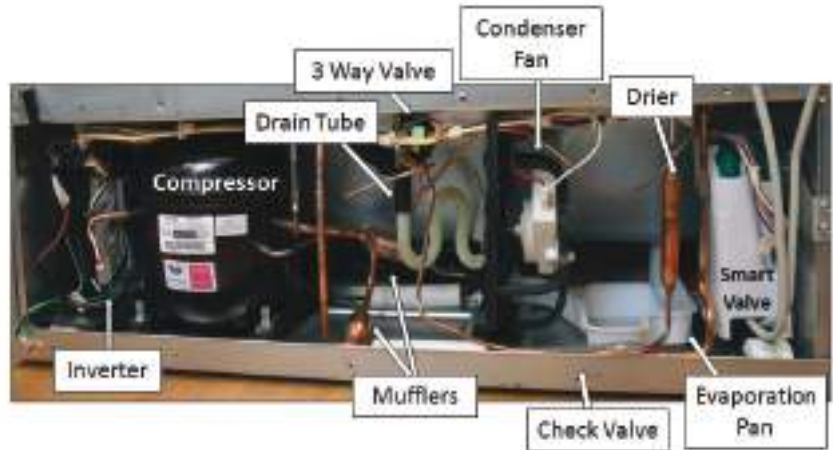

Embraco Variable Speed 3 Phase Compressors (Inverter Controlled)

This is not the split-phase design that you are familiar with. The new Variable Capacity Compressor modulates the motor speed depending upon the cooling capacity required. Speeds vary from 1650 R.P.M. up to maximum speed of 4500 R.P.M. These compressors are driven by " inverter technology" (PCB inverter board) using 170 VDC and a square waveform (Varying frequencies) This high voltage DC can then be switched to provide output for the windings of the compressor motor. The control circuitry has two functions, determine the proper speed for the compressor and develop drive voltages that will provide that speed. The new compressor has 3 windings which are alternately "switched off & on" by solid state transistors contained within the inverter board. Apart from the noise reduction of a compressor running at a lower speed, efficiency, and the obvious advantages of being able to call upon full speed by the indication of a temperature requirement, these new breed of compressors will eventually replace existing split phase designs being used at present.

Variable Speed
Compressor



THEORY OF OPERATION

Dual Evaporator Refrigerant System (cont.)

Compressor Drive Voltage (Example Only)

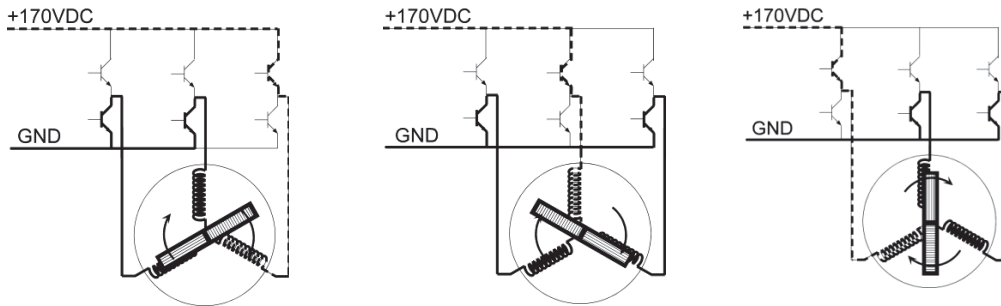

The frequency of the drive voltages determines the speed of the compressor. The motor is started at high speed to allow sufficient torque to get the system started. Once the compressor is turning, the frequency can be decreased to match the speed calculated by the control circuit.

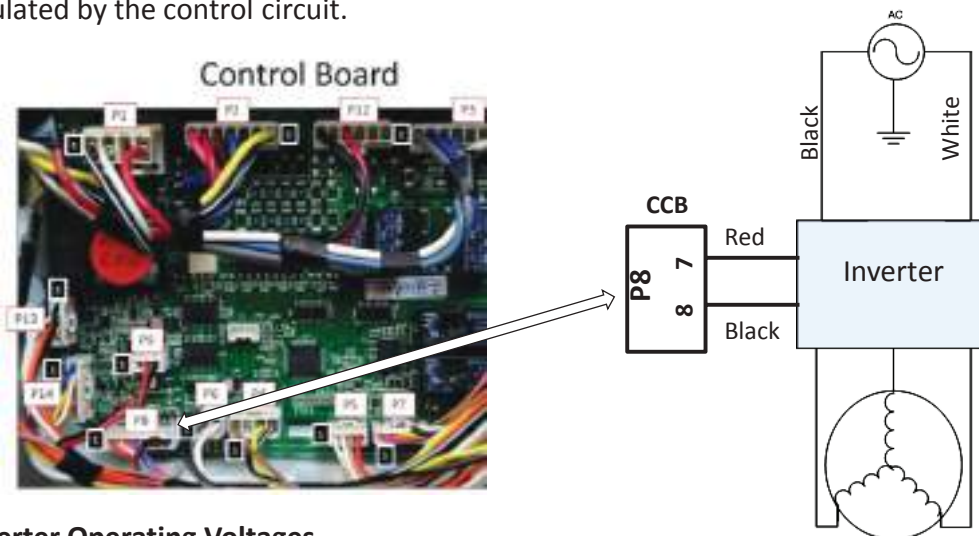

Inverter Operating Voltages

There are two operating voltages supplied to the Inverter. 120VAC supplied directly from the voltage source and 2-3 VDC across the red and black wires from P8 pins 7 and 8 located on the control circuit board.

Compressor	BTUH.....	Variable VEGZ7H
	Watt.....	80 Hz / 113 watts
	Current Lock rotor.....	3.3 amps± 15%
	Current Full load.....	3.3 amps± 15%
	Resistance Run windings.....	6.4 ohms± 15%
	Resistance Start windings.....	6.4 ohms± 8%@77°F
	Inverter.....	red and black wires = 3-8VDC,
		black and white wires= 120VAC

Compressor Resistance Check

Winding resistances:

A and B = 6.4 Ohms

A and C = 6.4 Ohms

B and C = 6.4 Ohms

Note: Tolerance plus or minus 15%

Checking for short to ground:

A to chassis ground = infinite Ohms

B to chassis ground = infinite Ohms

C to chassis ground = infinite Ohms

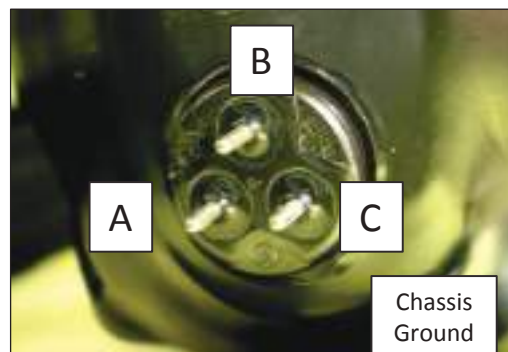

Dual Evaporator Refrigerant System (cont.)

3 Way Refrigerant Valve (RKV Valve)

The refrigeration system is called a sequential dual evaporator system.

Uniqueness:

- Two separate evaporator coils and capillary tubes.
- One for the refrigerator evaporator
- One for the freezer evaporator.
- A 3 way valve (RKV) is used to direct refrigerant flow to either the refrigerator or freezer evaporator coil depending on the compartment in need of cooling.
- Refrigerant flow is only directed through one evaporator at a time.

When replacing the magnetic coil, position the coil on the valve body and align the bendable tabs on the coil with the slots in the valve body.

Firmly seat the coil and use pliers to bend tabs over to lock the coil in place.

When brazing a new valve body, apply heat trap to the base of the valve body to reduce heat transfer to the valve.

Note: Do not heat the valve above 250 degrees F. (120 C.)

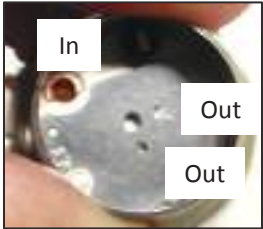
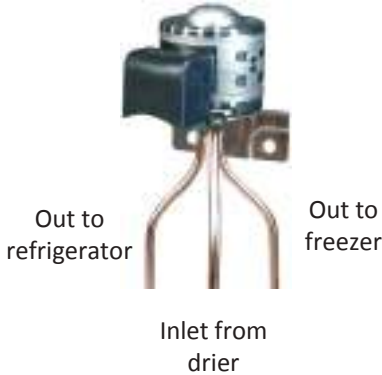
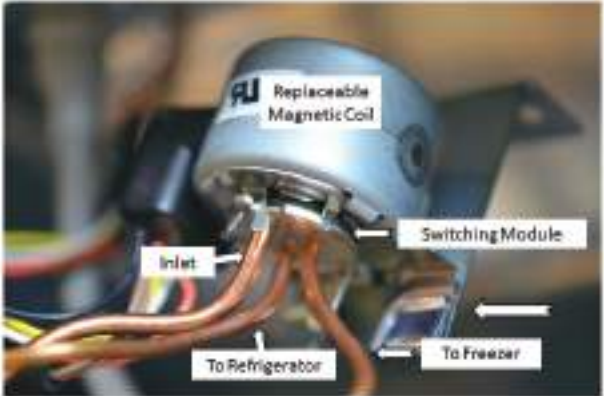

What's inside the valve body

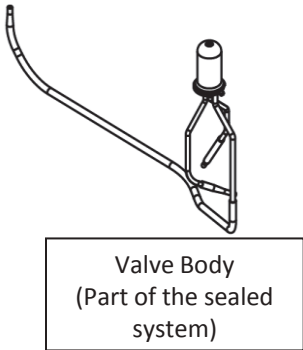

THEORY OF OPERATION

Dual Evaporator Refrigerant System (cont.)

Checking 3 way valve

The signal voltage used to position the 3 way valve is supplied by connector P13 located on the control circuit board. The signal is a binary signal that cannot be measured with a meter.

To test the 3 way valve operation use test 4 located on the Technical Data Sheet to energize the valve. Place your hand on the valve as you perform the test and you should be able to feel movement as the valve switches position.

Control Circuit Board

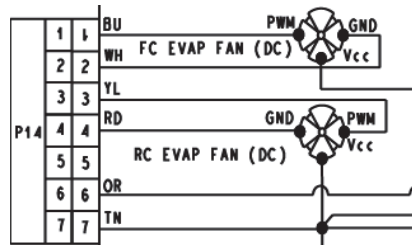

Power Supply Board

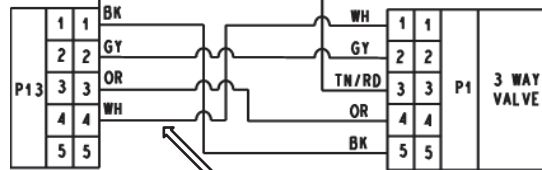
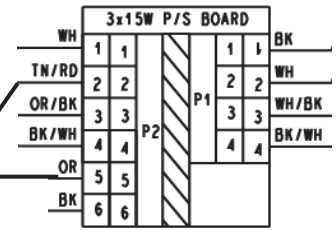

3 way refrigerant Valve

Checking the 3 way valve coil:

The 5 wire coil can be checked with an Ohmmeter. There are 5 wires on the coil that plug into the control circuit board. The Tan/Red wire is the power feed to the valve from the power supply board. The coil can be checked using the Tan wire at P14 pin# 6 and:

- P13, pin #1 Black wire
- P13, pin #2 Gray wire
- P13, pin #3 Orange wire
- P13, pin# 4 White wire

If you check between the TAN wire and any of the other 4 wires, you should get a reading between 47-50 ohms.

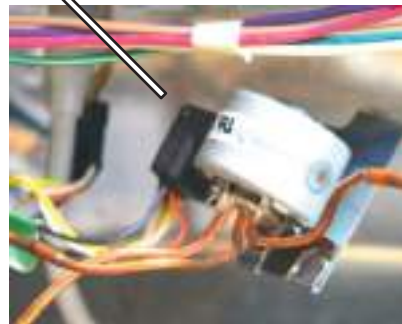

Condenser Fan

The condenser fan motor is classified as a 4 Watt stepper motor and driven by a solid state board inside the motor housing. A resistance check cannot be made on this type of motor.

If the motor does not operate, check for 120 VAC input to the motor. If the voltage is present and the motor does not operate replace the motor.

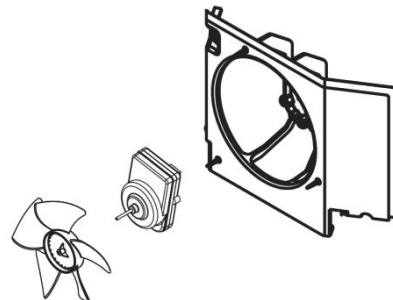

Condenser motor	Rotation..... Clockwise (facing end opposite shaft)
	RPM..... 1190 RPM
	Watt..... 4.1watts±15%
	Note: Fan blade must be fully seated on shaft to achieve proper airflow.

Dual Evaporator Refrigerant System (cont.)

Notes

THEORY OF OPERATION

Cooling Operation - Pull Down

- When first plugged in and the cabinet is warm the 3 way valve moves to the closed position. At the same time the compressor, condenser fan, refrigerator evaporator fan turn on.
- With the 3 way valve still in the closed position the compressor evacuates the refrigerant from the low side of the system and pumps it into the high side of the refrigerant system.
- After a predetermined time (approximately 2 minutes) the 3 way valve changes position allowing refrigerant to flow from the high side, through a capillary tube, and into the refrigerator evaporator coil allowing cooling of the refrigerator compartment. The refrigerator evaporator fan also turns on and circulates air across the evaporator coil. Heat is removed from the air and recirculated back to the compartment.
- The refrigerator compartment cooling will always be first.
- After 20 minutes the 3 way valve changes position from cooling the refrigerator to cooling the freezer. At this point refrigerant flows from the high side, through a capillary tube, and into the freezer evaporator coil allowing the cooling of the freezer compartment. The freezer evaporator fan also turns on and circulates air across the evaporator coil. Heat is removed from the air and recirculated back to the compartment.
- Cooling of the freezer compartment continues for 15 minutes and then switches back to the refrigerator.
- This operation continues until either compartment is satisfied at which point normal cooling mode begins.

Cooling Operation - Normal Cooling

- If the refrigerator compartment is calling for cooling the control determines if the refrigerator evaporator coil temperature has been above a predetermined temperature (approximately 35°F) for 15 minutes. This is to assure the evaporator coil is defrosted.
 - If the evaporator coil is below the predetermined temperature the refrigerator fan turns on to circulate air over the evaporator coil to defrost it. The fan will operate until the evaporator coil is above the predetermined temperature for 15 minutes.
 - If the evaporator coil is above the predetermined temperature but for less than 15 minutes the refrigerator fan turns on to circulate air over the evaporator coil to defrost it. This continues until the 15 minute time is met.
- When the evaporator coil is above the predetermined temperature for 15 minutes or more the 3 way valve moves to the closed position. At the same time the compressor, condenser fan, refrigerator evaporator fan turn on.
- With the 3 way valve still in the closed position the compressor evacuates the refrigerant from the low side of the system and pumps it into the high side of the refrigerant system.
- After a predetermined time (approximately 2 minutes) the 3 way valve changes position allowing refrigerant to flow from the high side, through a capillary tube, and into the refrigerator evaporator coil allowing cooling of the refrigerator compartment. The refrigerator evaporator fan also turns on and circulates air across the evaporator coil. Heat is removed from the air and recirculated back to the compartment.
- When the refrigerator temperature cools below the control setting it will either:
 - Turn the compressor, condenser fan, and evaporator fan off and switch the 3 way valve to the open position.
 - Or, if the temperature in the freezer compartment is above the control setting or is within a predetermined amount from the cut in temperature the 3 way valve changes position allowing refrigerant to flow from the high side, through a capillary tube, and into the freezer evaporator coil allowing the cooling of the freezer compartment. The freezer evaporator fan also turns on and circulates air across the evaporator coil. Heat is removed from the air and recirculated back to the compartment.
- If the freezer compartment is calling for cooling and the refrigerator is satisfied the compressor, condenser fan, evaporator fan turn on and 3 way valve changes position allowing refrigerant to flow from the high side, through a capillary tube, and into the freezer evaporator coil allowing the cooling of the freezer compartment.
- When the freezer temperature cools below the control setting the control will either:
 - Turn the compressor and condenser fan off and switch the 3 way valve position to open.
 - Or, if the temperature in the refrigerator compartment is above the control setting the cooling system will switch to cooling the refrigerator compartment.
- In either case the freezer evaporator fan will turn off unless the ice storage temperature control is calling for cooling.

Cooling Operation - Normal Cooling (cont.)

- When the ice storage compartment temperature is above the control setting
 - Both the freezer evaporator fan and ice maker blower turn on to circulate cold air from the freezer compartment to the ice making compartment and ice storage bin
- When the ice storage compartment temperature is below the control setting either of the following will occur
 - Both the freezer evaporator fan and ice maker blower turn off
 - Or if the freezer compartment is in it cooling state only the ice maker blower will shut off.

Notes

Section 5: Component Access

This section provides service parts access, removal and installation information concerning KitchenAid, Maytag and Whirlpool dual evaporator French Door Refrigerators. Refer to the Repair Parts List for your specific model to see what parts are available for ordering. Access may be shown to some assemblies that can be disassembled further.

- Machine Compartment Components
- Refrigerator Compartment Components
- Freezer Compartment Components
- Ice Maker and Dispenser Components

COMPONENT ACCESS

Machine Compartment Components

⚠ WARNING



Electrical Shock Hazard
Disconnect power before servicing.
Replace all parts and panels before operating.
Failure to do so can result in death or electrical shock.

MACHINE COMPARTMENT COVER

1. Unplug refrigerator or disconnect power.
2. Access the machine compartment components by removing screws holding machine compartment cover on back of refrigerator.

NOTE: The components located in the machine compartment have been used on previously manufactured bottom freezer refrigerators with these exceptions:

- 3 way refrigeration valve.
- Refrigerant check valve.
- Noise mufflers.

See Figure 1.

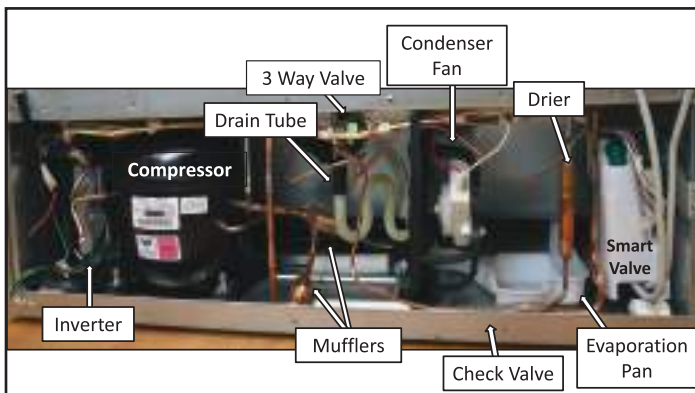

FIGURE 1

3 WAY REFRIGERANT VALVE

3. The 3 way refrigerant valve (RKV) consists of 2 separate components, a replaceable magnetic operating coil and the actuating valve (valve body). The valve body is part of the sealed system and requires no repair unless there is a leak at one of the joints (see *Refrigerant Recovery and Charging Procedures*, page 6-1). The magnetic operating coil is replaceable. See Figure 2.

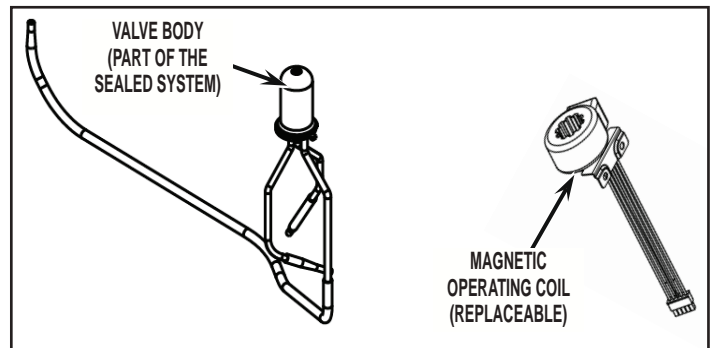

FIGURE 2

4. Disconnect wire harness connector to coil. Straighten the three metal tabs holding the coil on the valve and then lift off. See Figure 3.

NOTE: When replacing the magnetic coil, position the coil on the valve body and align the bendable tabs on the coil with the slots in the valve body. Firmly seat the coil and use pliers to bend tabs over to lock the coil in place.

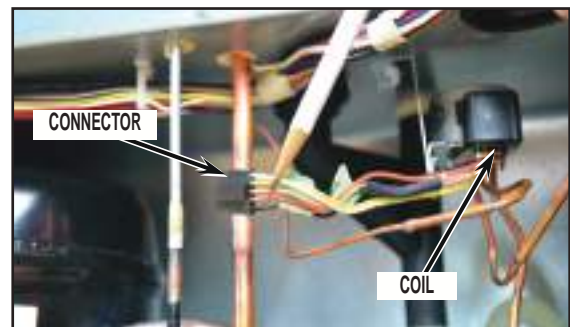

FIGURE 3

REFRIGERANT CHECK VALVE

NOTE: Complete *MACHINE COMPARTMENT COVER* instructions steps 1-2 (page 5-2 above).

1. The refrigerant check valve is used to isolate the evaporators and prevents refrigerant flow back into the evaporator. The refrigerant check valve is part of the sealed system and requires no repair unless there is a leak at one of the joints (see *Refrigerant Recovery and Charging Procedures*, page 6-1).

Machine Compartment Components (cont.)

SMART VALVE

NOTE: Complete *MACHINE COMPARTMENT COVER* instructions steps 1-2 (page 5-2).

1. To remove the smart valve, remove the screws securing the valve to the machine compartment base. See *Figure 4*.

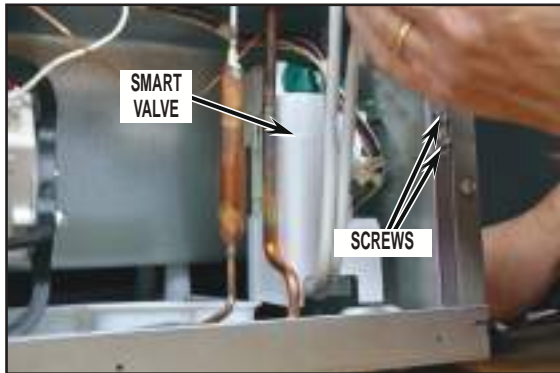

FIGURE 4

2. Unplug the wire harnesses. Disconnect the water lines. See *Figure 5*.



FIGURE 5

NOISE MUFLERS

NOTE: Complete *MACHINE COMPARTMENT COVER* instructions steps 1-2 (page 5-2).

1. The refrigerant noise mufflers are part of the sealed system and require no repair unless there is a leak at one of the joints (see *Refrigerant Recovery and Charging Procedures*, page 6-1). See *Figure 6*.

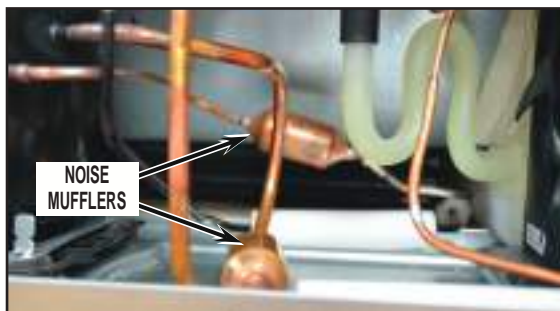

FIGURE 6

INVERTER

NOTE: Complete *MACHINE COMPARTMENT COVER* instructions steps 1-2 (page 5-2).

1. Remove the Phillips screw securing the inverter to the compressor terminal housing. See *Figure 7*.

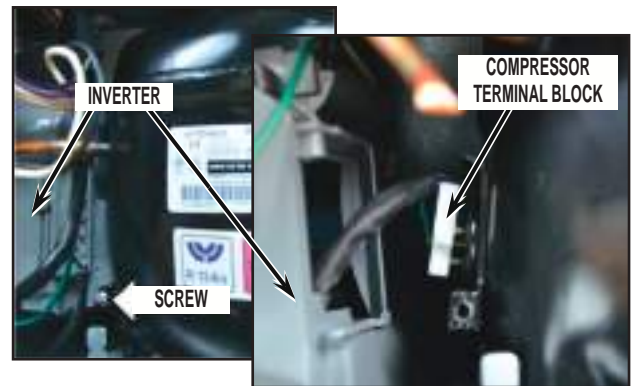

FIGURE 7

2. Position the main cabinet wiring harness out of the way to access the inverter. See *Figure 8*.



FIGURE 8

3. Pull the inverter far enough away from the compressor to disconnect the green chassis ground wire and the compressor terminal block. See *Figure 9*.

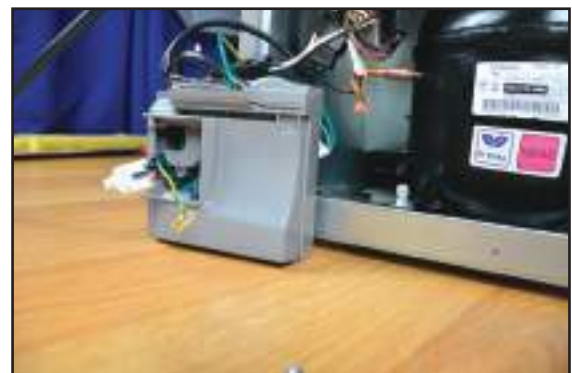

FIGURE 9

COMPONENT ACCESS

Machine Compartment Components (cont.)

COMPRESSOR

NOTE: Complete *MACHINE COMPARTMENT COVER* instructions steps 1-2 (page 5-2) and *INVERTER* instructions steps 1-3 (pages 5-3 to 5-4).

1. Access the compressor terminal block where shown in *Figure 10* to make resistance checks. The compressor is part of the sealed system, for replacement or repair of a leak at one of the joints see *Refrigerant Recovery and Charging Procedures*, page 6-1.



FIGURE 10

Notes

Refrigerator Compartment Components

⚠ WARNING



Electrical Shock Hazard

Disconnect power before servicing.

Replace all parts and panels before operating.

Failure to do so can result in death or electrical shock.

REFRIGERATOR DOORS, HINGES AND HANDLES

NOTE: See *Remove and Replace Refrigerator Doors* (page 2-3) for door and door hinge removal instructions. See *Handle Installation and Removal* (page 2-9) for door handle installation and removal instructions.

ICE BOX FASCIA

1. Unplug refrigerator or disconnect power.
2. Open both refrigerator compartment doors.
3. Remove all items from top shelves and remove shelves. See *Refrigerator Shelves* (page 2-9) for shelf installation and removal instructions.
4. Remove ice box fascia using a flat blade screwdriver. Pull out bottom of fascia to disengage upper tabs. See *Figure 1*.

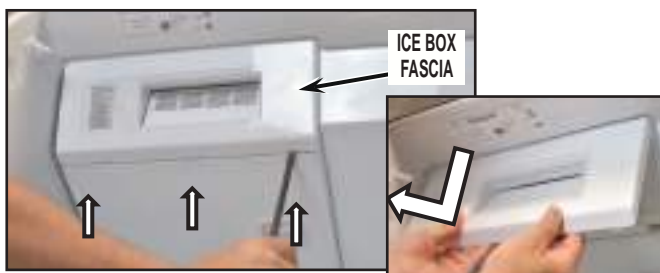

FIGURE 1

NOTE: If your ice box assembly has a revised ice box fascia with heater, you will need to disconnect the fascia heater wiring harness. See *Figure 2*.

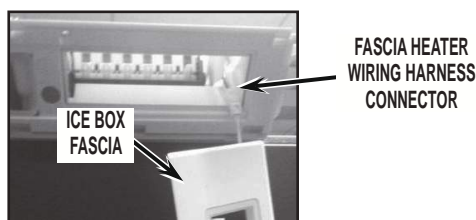

FIGURE 2

WATER FILTER

5. Locate water filter door, twist water filter counter-clockwise to remove. See *Figure 3*.



FIGURE 3

WATER RESERVOIR COVER

6. Using a 1/4" nut driver remove the two screws from under the water filter door. See *Figure 4*.



FIGURE 4

7. Starting from the ice box side, place a flat head screw driver between the water reservoir cover and refrigerator compartment liner creating enough room to place your hand between the two. See *Figure 5*.



FIGURE 5

8. Working from left to right, slide your hand between the water reservoir cover and refrigerator compartment liner to disengage the snaps. See *Figure 7*.



FIGURE 6

COMPONENT ACCESS

Refrigerator Compartment Components (cont.)

9. Disengage rear left snap. See *Figure 7*.



FIGURE 7

10. To remove the water reservoir cover, slide it forward and disconnect LED lighting connector. See *Figure 8*.



FIGURE 8

WATER RESERVOIR AND VALVE ASSEMBLY

11. Remove 3, 1/4" hex head screws. See *Figure 9*.



FIGURE 9

12. Disconnect ice maker fill tube from the isolation valve connected to the filter head. See *Figure 10*.



FIGURE 10

13. Disconnect electrical connections to water reservoir and valve assembly. Disconnect dispenser and ice maker fill tubes. See *Figure 11*.

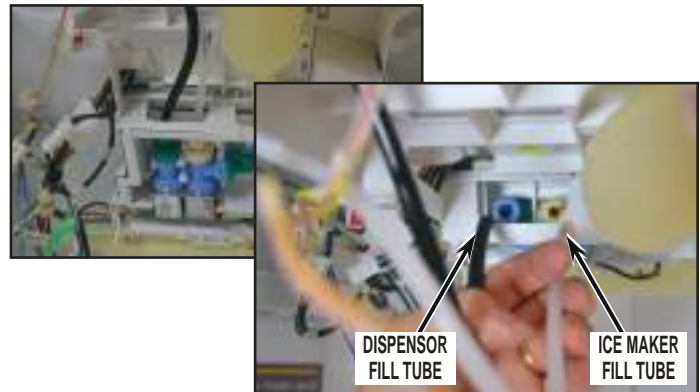

FIGURE 11

14. Drop the front of the housing and disengage the 3 rear tabs from the three slots in the top of the refrigerator cabinet. See *Figure 12*.



FIGURE 12

15. Disconnect 1/4" reservoir water tube from dual water valve and cut the 5 nylon wire ties to remove reservoir.

NOTE: Reservoir wire ties do not need to be removed to access remaining water reservoir and valve assembly components. See *Figure 13*.

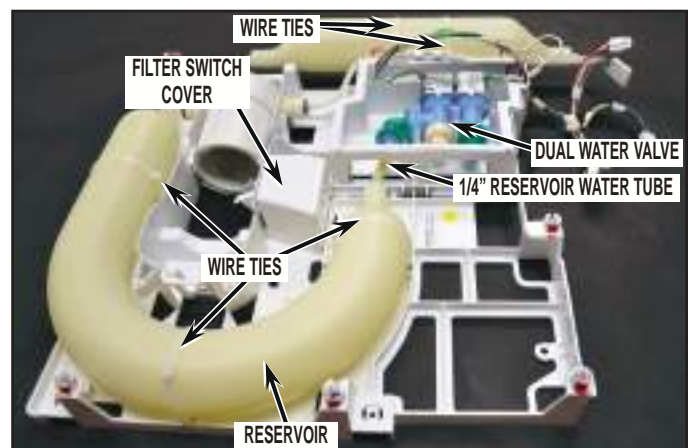

FIGURE 13

Refrigerator Compartment Components (cont.)

16. Lift dual water valve to remove. See *Figure 14*.

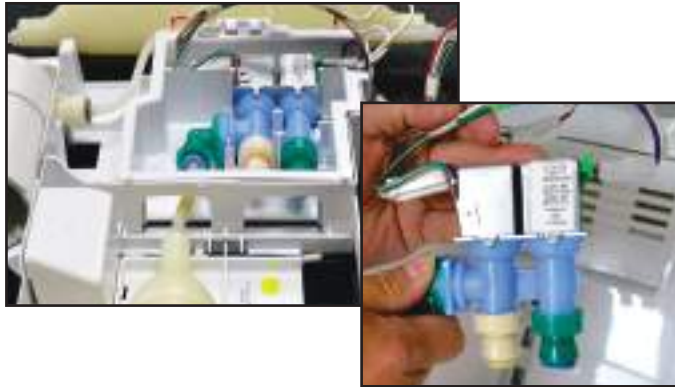

FIGURE 14

17. Depress tab and lift up on filter switch cover to disengage the 2 tabs on opposite side to remove cover. See *Figure 15*.

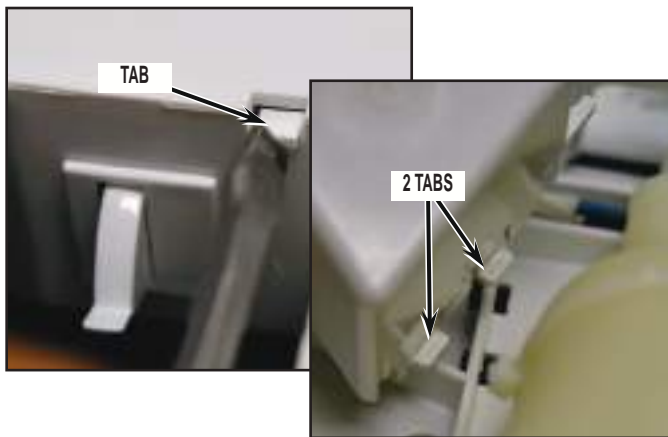

FIGURE 15

18. To remove filter switch, depress release tab and push the switch through, disconnect wires. See *Figure 16*.

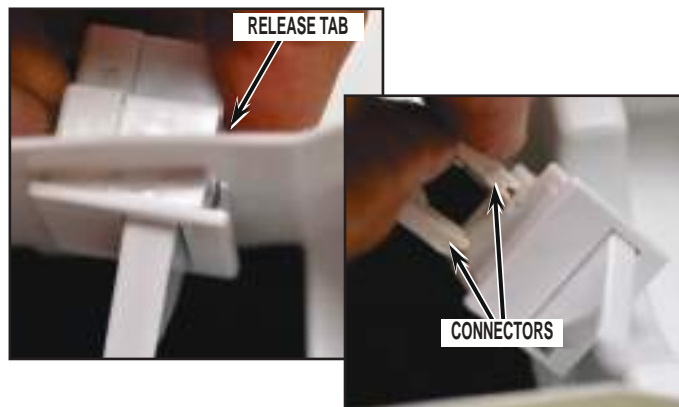

FIGURE 16

TEMPERATURE-CONTROLLED (DELI) DRAWER

NOTE: See *Temperature-Controlled Drawer* (page 3-10) for drawer removal instructions.

1. Unplug refrigerator or disconnect power.
2. Open both refrigerator compartment doors.
3. Remove all items on the bottom shelves. See *Refrigerator Shelves* (page 2-9) for shelf installation and removal instructions.
4. Remove the rail caps by inserting a wide straight blade between the cap and the rail approximately 1" from the bottom of the cap and twist. Repeat at the top of the cap if necessary. See *Figure 17*.

NOTE: There are 4 tabs securing the cap to the rail, 2 on the outside of the cap and 2 on the inside between the cap and the liner. A loud snap may be heard when the tabs release. Repeat process on the opposite side.

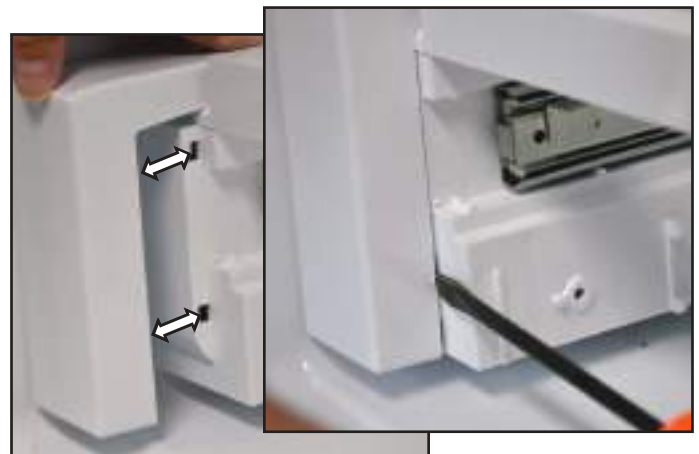

FIGURE 17

(DELI) DRAWER USER INTERFACE

5. To access the deli drawer user interface (UI) control board, release the 2 tabs in top of the wire harness cover and lift off. See *Figure 18*.



FIGURE 18

COMPONENT ACCESS

Refrigerator Compartment Components (cont.)

6. Remove the harness from the channels and unplug. See *Figure 19*.



FIGURE 19

7. Remove 2, 1/4" hex head screws (one on the left side and one on the right side) and release the 2 locking tabs to remove the deli UI front cover. See *Figure 20*.

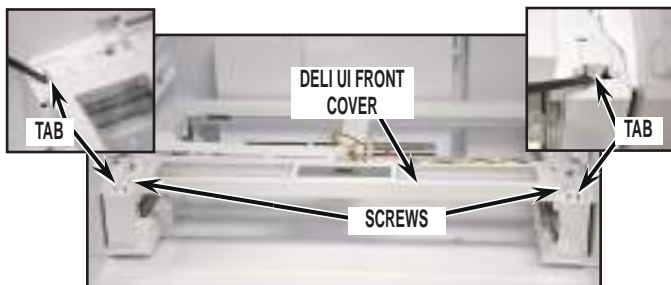

FIGURE 20

8. Remove the 2, 1/4" hex head screws on the bottom of the front cover and separate the deli user interface control board. See *Figure 21*.



FIGURE 21

9. Disconnect wire harness. Release thermistor locking tab and remove thermistor. See *Figure 22*.

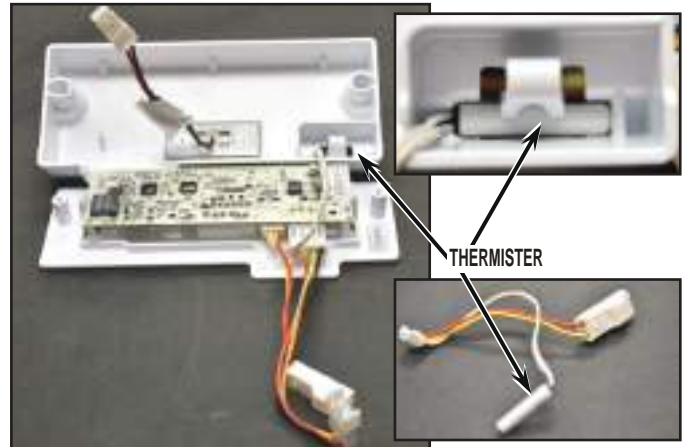

FIGURE 22

10. Remove side plate by lifting front and pulling forward off of tabs. See *Figure 23*.



FIGURE 23

11. Remove supports. See *Figure 24*.



FIGURE 24

Refrigerator Compartment Components (cont.)

AIR TOWER

NOTE: Complete *Refrigerator Compartment Components* instructions steps 1-10 (page 5-5 to 5-6) and *TEMPERATURE-CONTROLLED (DELI) DRAWER* instructions steps 1-7 (page 5-7 to 5-8) and steps 10 and 11 (page 5-8).

1. Remove any remaining items and shelves in Refrigerator Compartment. See *Refrigerator Shelves* (page 2-9) and *Crisper and Crisper Cover* (page 2-10) for shelf and crisper installation and removal instructions.
2. Release 6 locking tabs, there are 2 tabs at 3 locations along the center shelf rail. See *Figure 25*.

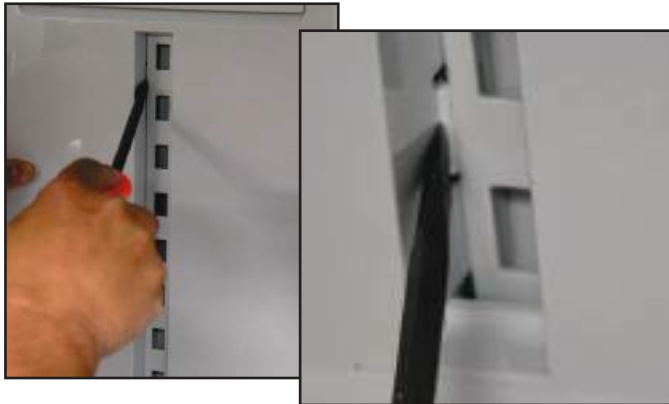

FIGURE 25

3. Drop down the air tower and remove. See *Figure 26*.



FIGURE 26

RC EVAPORATOR AND COMPONENT ACCESS

4. Remove 2, 1/4" hex head screws to remove RC evaporator cover to access RC evaporator and evaporator components. See *Figure 27*.

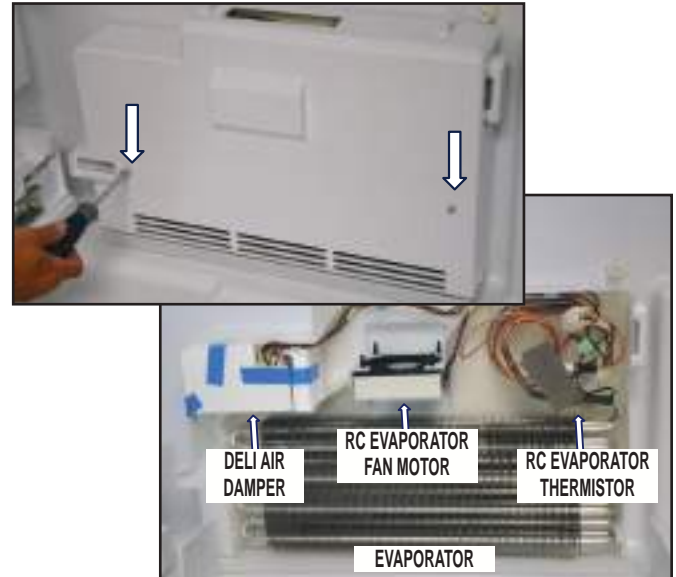

FIGURE 27

DELI AIR DAMPER

5. Remove tape to access deli air damper. See *Figure 28*.

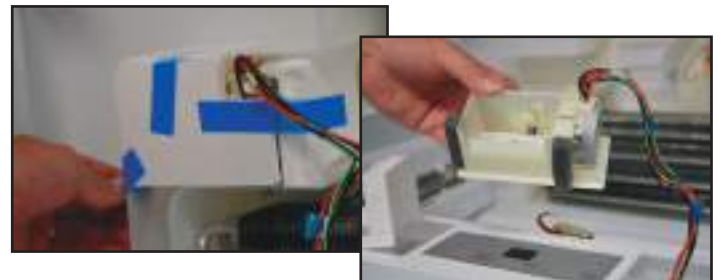

FIGURE 28

COMPONENT ACCESS

Refrigerator Compartment Components (cont.)

RC EVAPORATOR FAN MOTOR

6. Disconnect wire harness. See *Figure 29*.



FIGURE 29

7. Separate the fan motor from the housing. There are 4 rubber isolators that secure the motor to the housing. Remove the fan motor. See *Figure 30*.



FIGURE 30

RC EVAPORATOR THERMISTOR

8. Grasp the top and bottom of the thermistor housing and depress while you pull out on the housing. The evaporator thermistor is part of the RC wiring harness. See *Figure 31*.

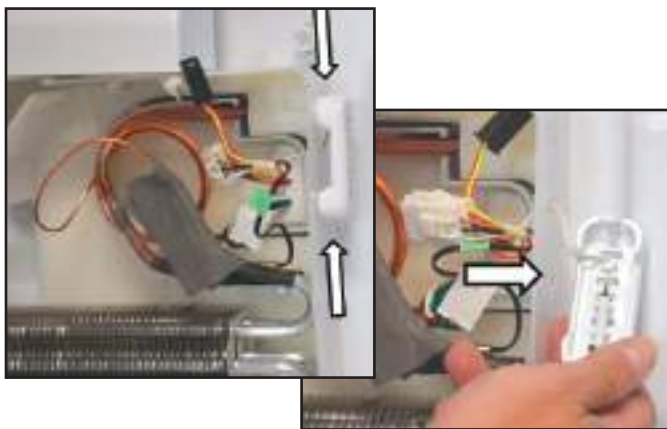

FIGURE 31

RC DEFROST THERMISTOR

9. RC defrost thermistor clips on the evaporator coil and senses the coil temperature. The defrost thermistor is part of the RC wiring harness. To replace, order the wiring harness. See *Figure 32*.



FIGURE 32

LED LIGHT MODULES

NOTE: Complete *Refrigerator Compartment Components* instructions steps 1-10 (page 5-5 to 5-6).

1. To remove LED light modules from water reservoir cover, lift out. See *Figure 33*.

NOTE: To remove LED modules from bottom of ice box assembly and cabinet walls, protect the liner while using a putty knife to pry them out.

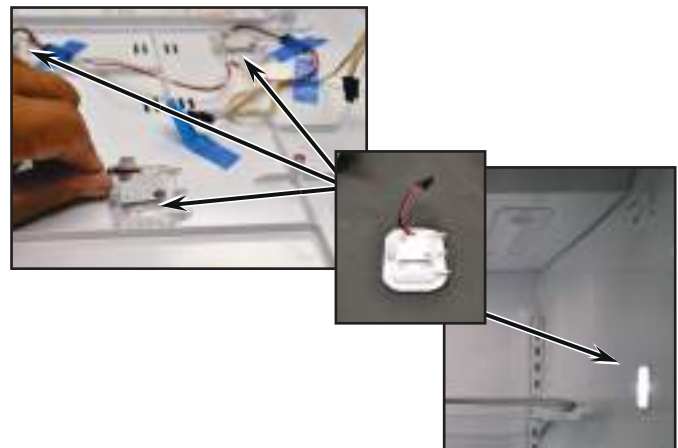

FIGURE 33

Refrigerator Compartment Components (cont.)

DOOR SWITCH

1. To remove the door switch from the cabinet wall, protect the liner while using a putty knife to pry it out. Disconnect harness connectors. See *Figure 34*.



FIGURE 34

Notes

COMPONENT ACCESS

Freezer Compartment Components

WARNING



Electrical Shock Hazard

Disconnect power before servicing.
Replace all parts and panels before operating.
Failure to do so can result in death or electrical shock.

FREEZER HANDLE

NOTE: See *Handle Installation and Removal* (page 2-9) for drawer handle installation and removal instructions.

FREEZER BASKETS AND RAILS

1. Remove 2, 1/4" screws on top/inside of freezer door and lift off the freezer drawer front.

NOTE: See *Remove and Replace Freezer Drawer Front* (page 2-6) for drawer front removal and replacement instructions.

2. Pull out lower basket as far as possible to access basket stops.
3. Insert a stiff blade putty knife behind the rail past the basket stop and force the rail inward while inserting a small blade screwdriver into the square slot in the rail. Pry out the freezer basket stop. Only one stop needs to be removed. See *Figure 1*.

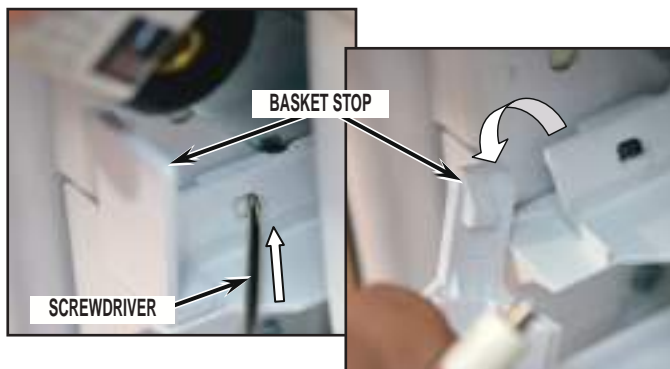

FIGURE 1

4. With a basket stop removed, pull out both baskets. Lift out the upper basket. Push the lower basket toward the rear slightly to disengage the hooks and lift out. See *Figure 2*.



FIGURE 2

5. Remove rail slides by pressing in tabs. See *Figure 3*.



FIGURE 3

6. Remove screw(s) and pull rail forward off of slots to remove complete rail. See *Figure 4*.



FIGURE 4

7. Remove rails by releasing tabs. See *Figure 5*.



FIGURE 5

Freezer Compartment Components (cont.)

FC EVAPORATOR AND COMPONENT ACCESS

NOTE: Complete *FREEZER BASKET AND RAILS* instructions steps 1-4 (page 5-12).

1. Remove the thermister cover by releasing 2 tabs on the right side. The freezer thermistor connector can be accessed behind the FC evaporator cover. See *Figure 6*.

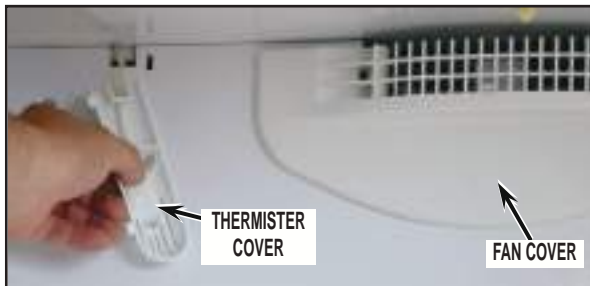

FIGURE 6

2. Release 2 tabs and then the center tab on the fan cover. See *Figure 7*.

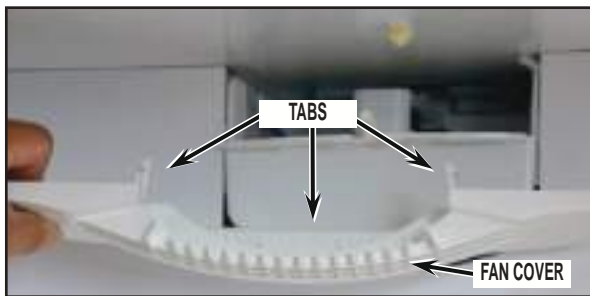

FIGURE 7

3. Remove the 4, 1/4" screws to remove FC evaporator cover to access FC evaporator and evaporator components. See *Figure 8*.

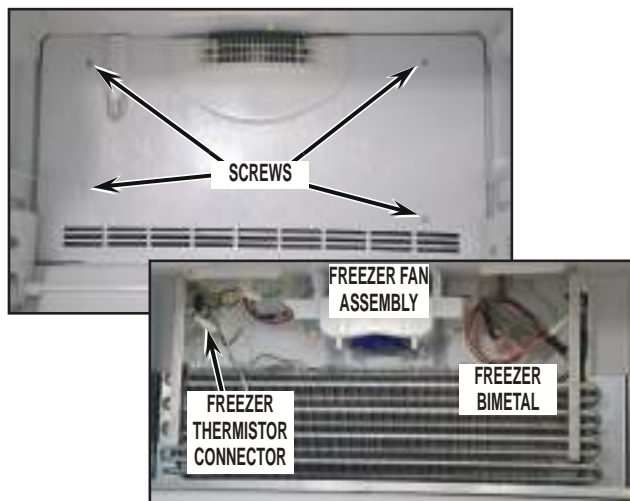

FIGURE 8

4. Remove 2 screws to remove the fan assembly. When installing fan make sure foam gaskets are in place. See *Figure 9*.

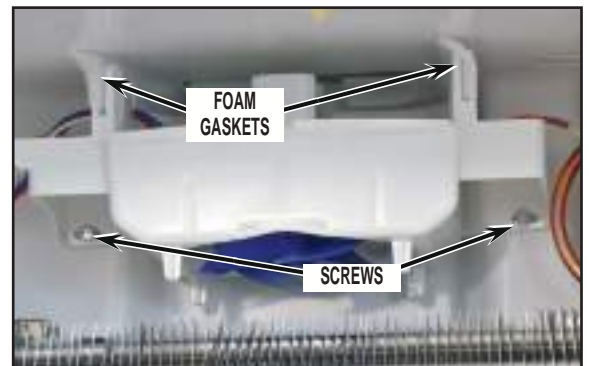

FIGURE 9

5. Remove noise mastic tape to access bimetal before installing. Unclip the bimetal from the suction line. See *Figure 10*.

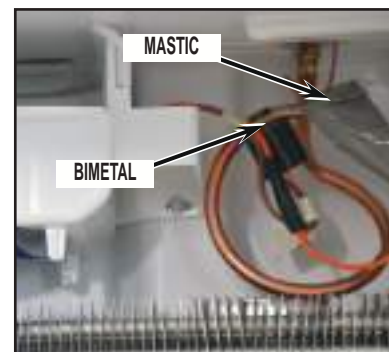

FIGURE 10

DOOR SWITCH

1. To remove the door switch from the cabinet wall, protect the liner while using a putty knife to pry it out. Disconnect harness connectors. See *Figure 11*.



FIGURE 11

Freezer Compartment Components (cont.)

Notes

Ice Maker and Dispenser Components

⚠ WARNING

<p style="text-align: center;">Electrical Shock Hazard</p> <p>Disconnect power before servicing.</p> <p>Replace all parts and panels before operating.</p> <p>Failure to do so can result in death or electrical shock.</p>

ICE BOX ASSEMBLY

1. Complete *Refrigerator Compartment Components* instructions steps 1-10 (page 5-6 to 5-7).
2. Disconnect electrical connections to ice box assembly. See *Figure 29*.



FIGURE 29

3. Disconnect ice maker fill tube from water valve. See *Figure 30*.

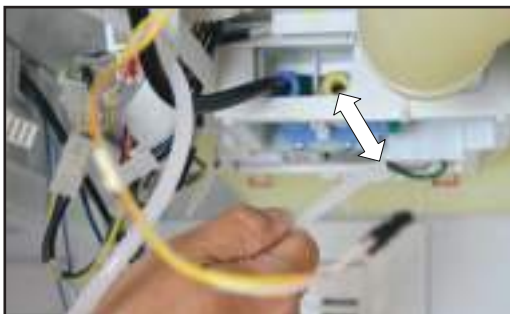

FIGURE 30

4. Locate the two 1/4" screws attaching the ice box assembly and remove using 1/4" nut driver while supporting ice maker. See *Figure 31*.



FIGURE 31

5. Drop down the front of the ice maker assembly and slide out to disengage the 2 tabs from the slots in the top of the cabinet. See *Figure 32*.



FIGURE 32

ICE MAKER FILL TUBE

6. Remove foil fill tube heater from the ice maker fill tube on the ice box. Remove all wires from channel on ice box assembly. See *Figure 33*.

NOTE: Some models have a ice box fascia with fascia heater wired through the foil fill tube heater, you may need to remove the fascia heater wires and grommet from the ice box cover.

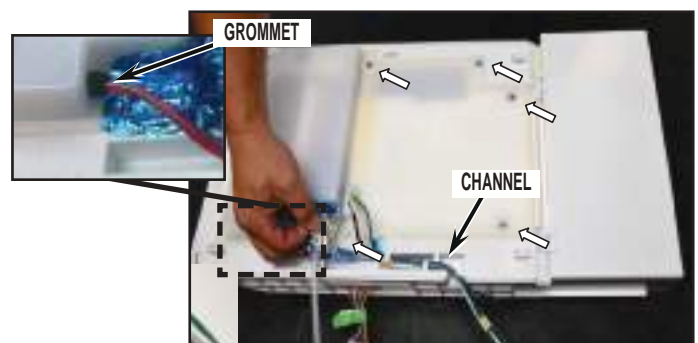

FIGURE 33

COMPONENT ACCESS

Ice Maker and Dispenser Components (cont.)

7. Use a straight blade screw driver to remove 5, 1/4" screws securing the ice box cover to the ice box assembly. See *Figure 33*.
8. Remove ice box cover while guiding ice maker harness through slot in ice box cover. Note lip for reassembly. See *Figure 34*.

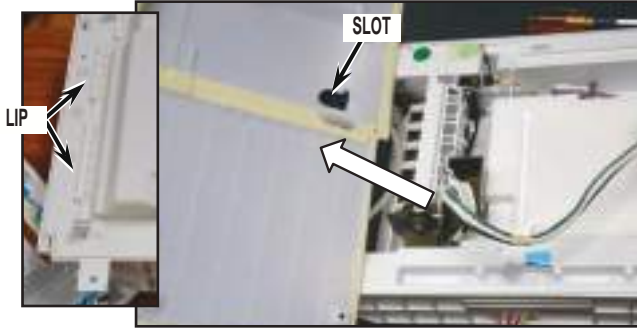

FIGURE 34

9. Remove ice maker fill tube by pushing into ice box cover and pulling through hole. See *Figure 35*.



FIGURE 35

ICE MAKER AND FAN MOTOR

10. Remove foam block. See *Figure 36*.

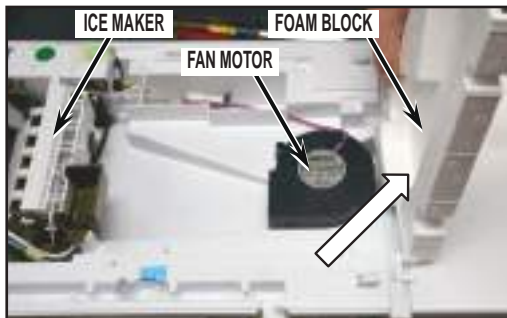

FIGURE 36

11. Lift out ice maker and disconnect the wire harness. See *Figure 37*.



FIGURE 37

12. Lift out the fan motor and disconnect the wire harness. See *Figure 38*.



FIGURE 38

DISPENSOR

1. To remove user interface (UI) assembly, insert small screwdriver to depress black tabs on underside of UI in these 3 locations. See *Figure 1*.

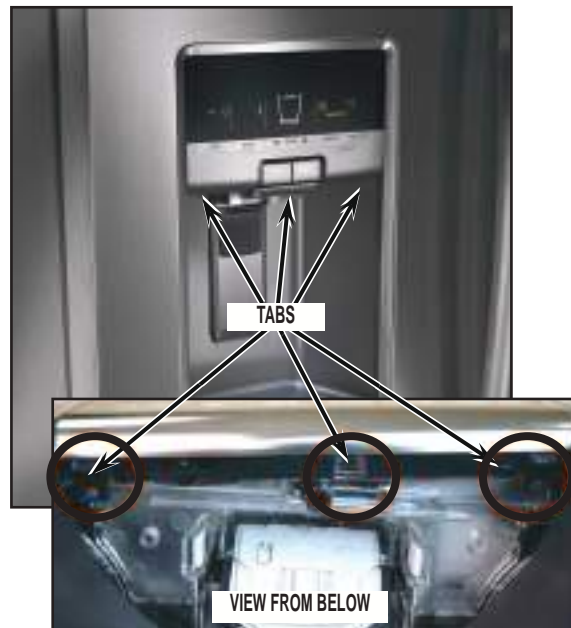

FIGURE 1

Ice Maker and Dispenser Components (cont.)

2. Pull out and lower UI, then disconnect board from wire harness connectors to remove. See *Figure 2*.

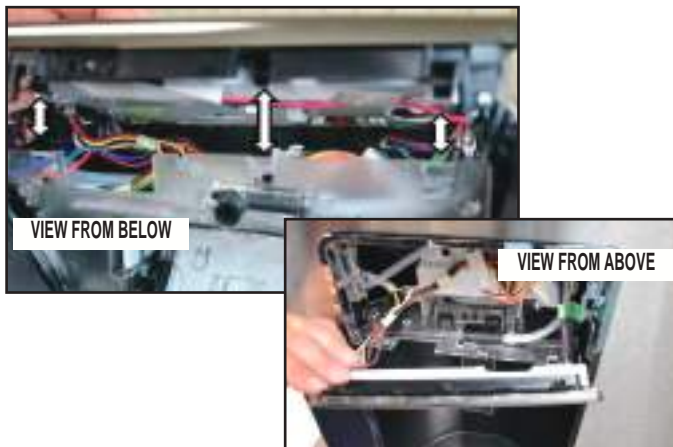

FIGURE 2

3. To remove ice door assembly, first remove (2) screws securing assembly to refrigerator door. See *Figure 3*.

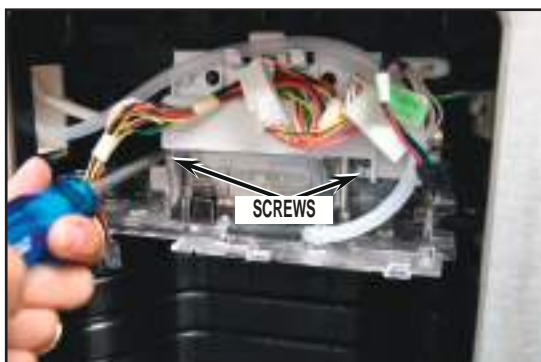

FIGURE 3

4. Disconnect dispenser hose by removing hose from locator channel and then by locating and depressing the tab to release. See *Figure 4*.

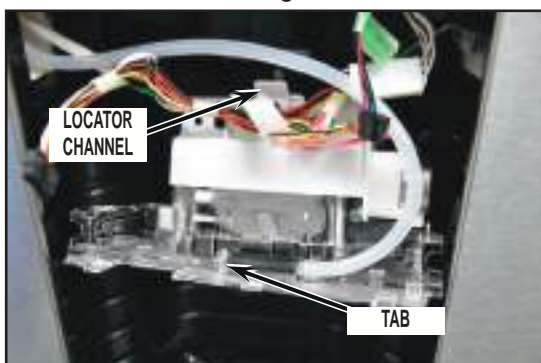

FIGURE 4

5. Pull out the assembly to service.

Notes

Section 6:

Diagnostics and Troubleshooting

This section contains an example of the Technical Data Sheet that is shipped with the refrigerator.

Note: Always refer to the Technical Data Sheet shipped with the refrigerator.

- Safety
- Tech Sheet Layout
- Service Diagnostics
- Troubleshooting

DIAGNOSTICS & TROUBLESHOOTING

Safety

⚠ WARNING



Electrical Shock Hazard

Disconnect power before servicing.

Replace all parts and panels before operating.

Failure to do so can result in death or electrical shock.

⚠ DANGER



Electrical Shock Hazard

Only authorized technicians should perform diagnostic voltage measurements.

After performing voltage measurements, disconnect power before servicing.

Failure to follow these instructions can result in death or electrical shock.

Voltage Measurement Safety Information

When performing live voltage measurements, you must do the following:

- Verify the controls are in the off position so that the appliance does not start when energized.
- Allow enough space to perform the voltage measurements without obstructions.
- Keep other people a safe distance away from the appliance to prevent potential injury.
- Always use the proper testing equipment.
- After voltage measurements, always disconnect power before servicing.

Tech Sheet Layout

IMPORTANT: Always use the Technical Data Sheet shipped with the product. The tech sheet information depicted in this Job Aid is an example only.

Technical Data Sheet

The Technical Data contains information needed for diagnosis and troubleshooting and is shipped with every refrigerator. There are 4 separate pages combined into one large double sided sheet. If the sheet is missing, the information can be found on Servicematters.com.

Page One:

Safety Panels

Performance chart

⚠ WARNING



Electrical Shock Hazard

Disconnect power before servicing. Replace all parts and panels before operating. Failure to do so can result in death or electrical shock.

⚠ DANGER



Electrical Shock Hazard

Only authorized technicians should perform diagnostic voltage measurements. After performing voltage measurements, disconnect power before servicing. Failure to follow these instructions can result in death or electrical shock.

FOR SERVICE TECHNICIANS USE ONLY

No-Load Performance, Controls in Normal Position						
Ambient °F	Kwh/24 hr ±0.4	Percent Run Time ±10	Cycles/24 hr ±10	Refrigerator Compartment Average Food Temperature ±4 °F	Freezer Compartment Average Food Temperature ±5 °F	Ice maker Compartment Average Food Temperature ±5 °F
70° 90° 110°*	70° 90° 110°*	70° 90° 110°*	70° 90° 110°*	70° 90° 110°*	70° 90° 110°*	70° 90° 110°*
29 ou ft	0.9 1.5 2.8	50 70 90	28 22 10	37 37 37	0 0 0	24 24 24

Temperature Relationship Test Chart

Ambient °F	Refrigerator Evaporator Inlet/Outlet ±5 °F	Freezer Evaporator Inlet/Outlet ±5 °F	Suction Line ±7 °F	Average Total WetBtag ±10%	Suction Pressure ±2 PSIG	Head Pressure ±0 PSIG
70° 90°*	70° 90°*	70° 90°*	70° 90°*	70° 90°*	70° 90°*	70° 90°*
29 ou ft	15 20	-11 -8	80 104	80-100 80-100	6.0 3.6	70 125

6-2 ■

Tech Sheet Layout (cont.)

Component Chart

This chart lists the major load component specifications including RPM, Rotation, voltage, resistance and Wattage.

Page One Continued:

1. Component Specifications
2. Controls
3. Ice & Water

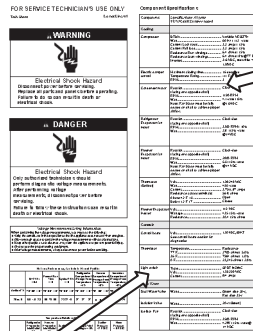

Controls	
Control board	Volt..... 120 VAC, 60 HZ See control board section for diagnostics
Thermistor	Temperature..... Resistance 77°F..... 2,700 ohms± 5.0% 36°F..... 964 ohms± 1.0% 0°F..... 23,345 ohms± 2.0%
Light switch	Type..... SPDT NO/NC Volt..... 125/250 VAC Current..... 8/4 amps
Ice & Water	
Dual Water Valve	Watts..... Green side 20w, Red side 35w
Isolation Valve	Watts..... 20w (Green)
Ice Box Fan	Rotation..... Clockwise (facing end opposite shaft) RPM..... 3500 RPM Watt..... 4.2W ±15% watts@ 14 VDC

Component	Specifications all parts 115VAC/60HZ unless noted
Cooling	
Compressor	BTUH..... Variable VE GZ7H Watt..... 60 Hz / 113 watts Current Lock rotor..... 3.3 amp± 15% Current Full load..... 3.3 amp± 15% Resistance Run windings..... 6.4 ohm± 15% Resistance Start windings..... 6.4 ohm± 8% @ 77°F Inverter..... 3-6 VDC, red/white = 120VAC
Electric damper control	Maximum closing time..... 16 seconds Temperature Rating..... -11°F - 110°F RPM..... 3
Condenser motor	Rotation..... Clockwise (facing end opposite shaft) RPM..... 1190 RPM Watt..... 4.1 watts± 15% Note: Fan blade must be fully seated on shaft to achieve proper airflow. @115VAC
Refrigerator Evaporator fan motor	Rotation..... Clockwise (facing end opposite shaft) RPM..... 3300 RPM ± 10% Watt..... 2.8 ± 15% watts @14VDC
Freezer Evaporator fan motor	Rotation..... Clockwise (facing end opposite shaft) RPM..... 2800 RPM Watt..... 5.5±15% watts Note: Fan blade must be fully seated on shaft to achieve proper airflow. @14 VDC
Thermostat (Defrost)	Volt..... 120/240 VAC Watt..... 495 watts Current..... 3.75/1.67 amps Resistance across terminals: Above 42°F ±5°..... Open Below 12°F ±7°..... Closed
Freezer Evaporator Heater	Volt..... 115 VAC Wattage..... 435 ±5% watts Resistance..... 30.4 ±5% ohms

Tech Sheet Layout (cont.)

Page Two

Page 2 Contains information on how to access and interpret the built in diagnostic program. This test is used to check the Control Circuit Board. The test are numbered from 1-73. Not all tests are used for servicing and are so noted. Select the test that corresponds to customers complaint. You do not have to access every test.

TO ENTER SERVICE DIAGNOSTICS Mode:

- Press SW1 and SW2 simultaneously for 3 seconds.
- Release both buttons when you hear the CHIME indicator.
- Unit must not be in Lockout prior to entering SERVICE MODE.
- The display will show 01 to indicate the control is in step 1 of the diagnostics

Examples of the test available

Service Test - 1 FC Thermistor• The board will check the resistance value of the Thermistor and display flashes results on the TempDisplay. (01 = Pass, 02 = Open, 03 = Short)

Service Test - 3 Evaporator fan motor and air baffle motor

- Control the RC & FC Evaporator Fan Mtrs. by depressing SW3 (01= Both Fan Mtr. off. 02 =FC Fan on.)
- Depress SW3 once to advance. Step 3 will flash quickly and advances to steps 13/23 very quickly. The result is RC Fan on, Pantry Air Damper on. Pantry Air Damper will open and close automatically. (13= Damper Open.23= Damper Closed). Verify air flow inside pantry on left hand side when damper is open, (13 displayed). Airflow in pantry will cease when 23 is displayed).
- Depress SW3 to advance to last step. (04 = Both RC & FC fans on).

Service Test - 4 Compressor/ condenser fan motor/evaporator fan

- Control the Sealed System loads selecting SW3 (01 = Initialize Dual Evap Valve in home position (4min), 02 =Close both RC&FC Evap Valve (1min), 03 = Turn compressor ON (1min), 04 = Keep compressor ON, drive the valve to RC position & turn RC fan ON, 05 = Keep compressor ON, drive the valve to FC position & turn FC fan ON. Verify air flow from the evaporator

Control board Troubleshooting

SWITCH DIAGRAM

SW1 SW2 SW3 SW4 SW5

Notes:

- SW1: Press and hold for 3 seconds to enter Service Mode.
- SW2: Press and hold for 3 seconds to exit Service Mode.
- SW3: Press once to advance to the next test step.
- SW4: Press once to return to the start of the test sequence.
- SW5: Press once to exit the diagnostic mode.

Test Results:

Test Step	Result
01	Pass
02	Open
03	Short

Service Test - 1 FC Thermistor

The board will check the resistance value of the Thermistor and display flashes results on the TempDisplay. (01 = Pass, 02 = Open, 03 = Short)

Service Test - 3 Evaporator fan motor and air baffle motor

Control the RC & FC Evaporator Fan Mtrs. by depressing SW3 (01= Both Fan Mtr. off. 02 =FC Fan on.)

- Depress SW3 once to advance. Step 3 will flash quickly and advances to steps 13/23 very quickly. The result is RC Fan on, Pantry Air Damper on. Pantry Air Damper will open and close automatically. (13= Damper Open.23= Damper Closed). Verify air flow inside pantry on left hand side when damper is open, (13 displayed). Airflow in pantry will cease when 23 is displayed).
- Depress SW3 to advance to last step. (04 = Both RC & FC fans on).

Service Test - 4 Compressor/ condenser fan motor/evaporator fan

Control the Sealed System loads selecting SW3 (01 = Initialize Dual Evap Valve in home position (4min), 02 =Close both RC&FC Evap Valve (1min), 03 = Turn compressor ON (1min), 04 = Keep compressor ON, drive the valve to RC position & turn RC fan ON, 05 = Keep compressor ON, drive the valve to FC position & turn FC fan ON. Verify air flow from the evaporator

Tech Sheet Layout (cont.)

Page 3

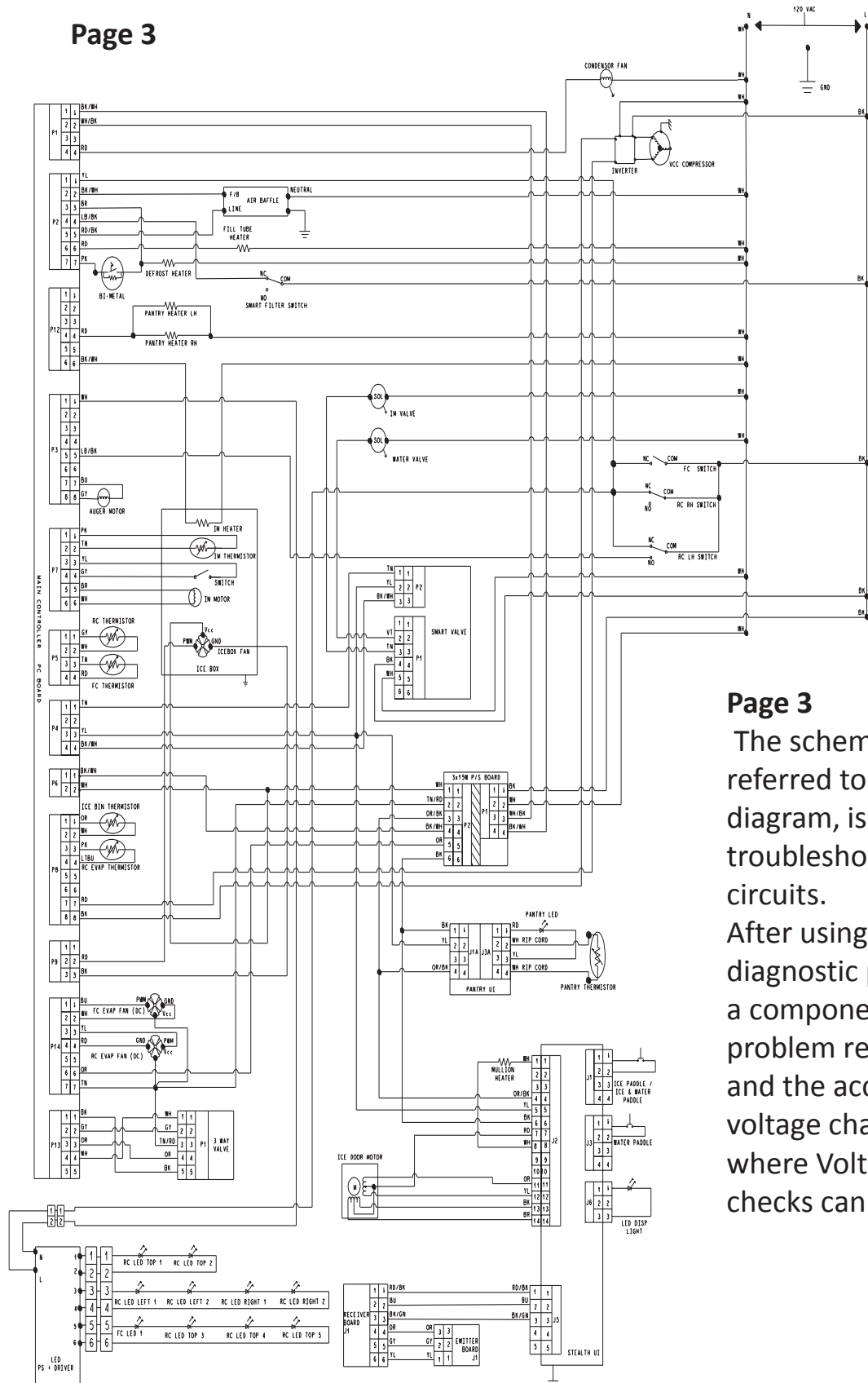

Page 3
 The schematic wiring, often referred to as a ladder diagram, is used for troubleshooting electrical circuits. After using the built in diagnostic program to identify a component or circuit problem refer to this sheet and the accompanying voltage chart to determine where Voltage and Resistance checks can be made.

Tech Sheet Layout (cont.)

Page 3 Cont.

A Voltage test Point chart is located on the wiring schematic . The chart is divided into sections:

- Power Supply
- Main Control
- Smart Valve
- Receiver/Emitter
- UI (Doty) Board
- Dispenser Board

Use the diagnostic program to energize the suspect circuit and check the corresponding Test Points identified in the chart.

	FROM	TO	DLTAG	Conditions		
POWER SUPPLY	P1	P1-1	P1-2	115VAC	Constant 115 VAC	
		P1-3	P1-4		Constant 115 VAC	
	P2	P2-1	P2-4		Constant 14VDC	
		P2-2	P2-5		Constant 14VDC	
		P2-3	P2-6		Constant 14VDC	
					Constant 14VDC	
MAIN CONTROL	P1	P1-1	P1-2	115VAC	Constant 115VAC	
		P1-2	P1-4		Constant 115VAC	
	P2	P2-1	P1-2		RC or FC Door open 115V. Doors Closed = 0V	
		P2-2	P1-2		Air Baffle feedback. Activate Service Test 3, Step 3	
		P2-3	P1-2		Heater, Bi-Metal bypass. Service Test 6. 115V if Bimetal closed.	
		P2-4	P1-2		Water Filter removed 115V. Filter Installed 0V	
		P2-5	P1-2		Air Baffle output. Activate Service Test 3, Step 3	
		P2-6	P1-2		Fill Tube heater output. Service Test 19. 01=115V, 02=0v	
	P3	P2-7	P1-2		Heater output, w/Bi-Metal. Service Test 6. 115V	
		P3-1	P2-1		RC or FC Door open 115V. Doors Closed = 0V	
	P4	P3-5	P1-2		Left RC door must be closed = 115V. Opens = 0V	
		P3-7	P3-8	130VDC	Auger output. LH RC door Closed, Activate Ice Paddle = 130-140VDC	
	SMART VALVE	P4	P4-1	P4-4	14 VDC	Constant 14VDC
			P4-3			COMMUNICATION
		P5	P5-1	P5-2	5VDC	RC thermistor output = 1.5-5.0 VDC
			P5-3	P5-4		FC thermistor output = 1.5-5.0 VDC
		P7	P7-1	P7-2	5VDC	IM thermistor output = 1.5-5.0 VDC
			P7-5	P7-6	14VDC	IM Mtr. Output. Test 57, Sw3 to activate. Up to 2min delay
		P8	P8-1	P8-2	5VDC	Ice Bin Thermistor output = 1.5-5.0 VDC
			P8-3	P8-4		RC Evap. thermistor output = 1.5-5.0 VDC
		P9	P8-7	P8-8	3-6VDC	Inverter output 3-6 VDC Constant
			P9-2	P9-3	14VDC	Icebox fan output. Test 36, Sw3 to activate. 01=14VDC
		P12	P12-4	P1-2		Pantry heater output. Test 73. 01=115VAC
			P12-6	P1-2		IM heater output. Test 58. Sw3 to activate 01= 115VAC
P13	P13-1	P13-2		3way refrigerant valve, Cannot check voltage output		
	P13-3	P13-4		3way refrigerant valve, Cannot check voltage output		
P14	P14-1	P14-2		FC Fan mtr. Output. Activate Service Test 3, step 2		
	P14-3	P14-4	14VDC	RC Fan Mtr. Output. Activate Service Test 3, step 3		
	P14-7	P14-6		Constant 14VDC		
Receiver / Emitter	P1	P1-2	P1-5	115VAC	Push water dispenser Paddle to activate	
		P1-3	P1-5	115VAC	Activate Service Test 45 in diagnostics, Press Sw3 = 115VAC	
	P2	P1-4	P1-5	115VAC	115VAC Constant	
		P2-1	P2-3	14VDC	14VDC Constant	
Dojink UI	J1A	J1A-1	J1A-1	14VDC	14VDC Constant	
		J1A-2			COMMUNICATION	
	J3A	J3A-1	J3A-3	14VDC	LED output. 14VDC when turned on.	
J3A-2		J3A-4	5VDC	Pantry Thermistor output = 1.5-5.0 VDC		
Dispenser Board	J1	J1-1	J1-2	14VDC	0 VDC when ice dispenser pad is pressed, 14VDC* when released	
		J1-1	J1-3	14VDC	Ice dispenser button is pressed* (if J1-3 used)	
		J1-2	J1-3	14VDC	Ice dispenser pad is pressed* (if J1-3 used)	
	J2	J2-1	J2-8	14VDC	Flipper Mullion Heater. Test 35, Press Sw3 = 14 VDC	
		J2-4	J2-6	14VDC	14VDC Constant	
		J2-7	J2-11	14VDC	Ice door stepper motor is active*	
		J2-7	J2-12	14VDC	Ice door stepper motor is active*	
		J2-7	J2-13	14VDC	Ice door stepper motor is active*	
	J3	J2-7	J2-14	14VDC	Ice door stepper motor is active*	
		J3-1	J3-2	14VDC	0 VDC when water dispenser pad is pressed, 14 VDC when released	
	J5	J3-1	J3-3	14VDC	'water dispenser button is pressed' (if J3-3 used)	
		J3-2	J3-3	14VDC	'water dispenser pad is pressed' (if J3-3 used)	
	J6	J5-1	J5-3	14VDC	14VDC Constant	
		J5-2			COMMUNICATION	
	J6-1	J6-3	14VDC	Dispenser light on.		

*Pulsing DC signal. May not be read with all meters.

Tech Sheet Layout (cont.)

Page 4

The pictorial diagram on page 4 of the Technical Data Sheet identifies the location of all wire harness connectors and list the associated wire colors. Use this diagram when looking for loose connections or open wires in foamed in wire harnesses.

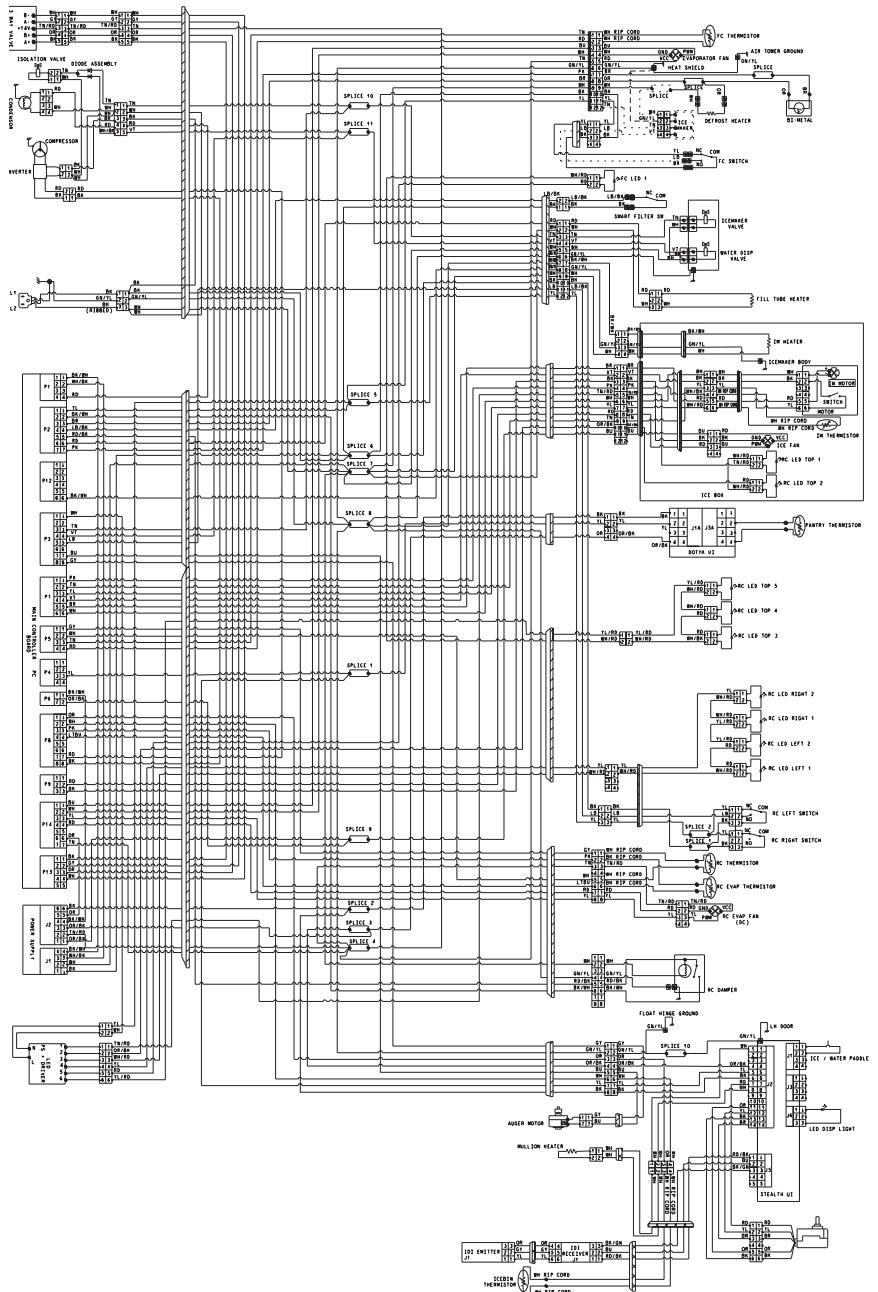

Service Diagnostics

FOR SERVICE TECHNICIAN'S USE ONLY

⚠ WARNING

<p>Electrical Shock Hazard Disconnect power before servicing. Replace all parts and panels before operating. Failure to do so can result in death or electrical shock.</p>

⚠ DANGER

<p>Electrical Shock Hazard Only authorized technicians should perform diagnostic voltage measurements. After performing voltage measurements, disconnect power before servicing. Failure to follow these instructions can result in death or electrical shock.</p>

Voltage Measurement Safety Information
<p>When performing live voltage measurements, you must do the following:</p> <ul style="list-style-type: none"><input type="checkbox"/> Verify the controls are in the off position so that the appliance does not start when energized.<input type="checkbox"/> Allow enough space to perform the voltage measurements without obstructions.<input type="checkbox"/> Keep other people a safe distance away from the appliance to prevent potential injury.<input type="checkbox"/> Always use the proper testing equipment.<input type="checkbox"/> After voltage measurements, always disconnect power before servicing.

IMPORTANT: Always used the Technical Data Sheet shipped with the product. The tech sheet information depicted in this Job Aid is an example only.

Service Diagnostics (cont.)

Diagnostics Mode:

Use the diagnostic program to isolate and verify customer complaint.

Select the Service test(s) that correspond to the complaint.

Some tests listed are used in the manufacturing process only and are identified as such.

IMPORTANT: Always used the Technical Data Sheet shipped with the product. The tech sheet information depicted in this Job Aid is an example only.

Control board Troubleshooting

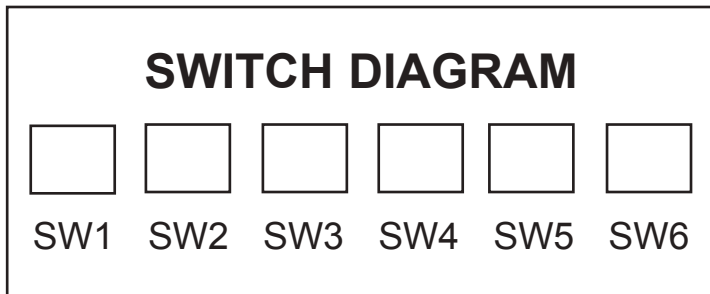

To ENTER SERVICE DIAGNOSTICS Mode:

Press SW1 and SW2 simultaneously for 3 seconds. Release both buttons when you hear the CHIME indicator.

Unit must not be in Lockout prior to entering SERVICE DIAGNOSTIC MODE.

The display will show 01 to indicate the control is in step 1 of the diagnostics routine.

To EXIT SERVICE DIAGNOSTICS Mode: do one of the following 3 options:

- Press SW1 and SW2 simultaneously for 3 seconds.
- Disconnect the product from power.
- Allow 20 minutes to pass.

Following the exit of the diagnostic mode, the controls will then resume normal operation.

Cooling diagnostics are steps 1 through 7 and 32 through 39. Dispensing diagnostics are steps 8 through 31. Each step must be manually advanced. Press SW5 to move to the next step in the sequence. Press SW4 to back up in the sequence to the previous step. Diagnostics will begin at Step 1. Each step is displayed in the two digits of the dispenser user interface display. The step results are displayed in the two digits on dispenser user interface display 2 seconds after the step number is displayed. An amber order filter light will be shown to designate that the step number is being displayed and a red replace filter light will be shown to designate that the status of the step is being displayed. All button and pad inputs shall be ignored and all inputs shall be off except as described in the actions for each step.

Service Test - 1 FC thermistor

- The board will check the resistance value of the thermistor and display flashes results on the Temp Display. (01 = Pass, 02 = Open, 03 = Short)

Service Test - 2 RC thermistor

- The board will check the resistance value of the thermistor and display the results on the Temp Display (01 = Pass, 02 = Open, 03 = Short)

Service Test - 3 Evaporator fan motor and air baffle motor

- Control the RC & FC Evaporator Fan Mtrs. by depressing SW3 (01= Both Fan Mtr. off. 02 =FC Fan on.)
- Depress SW3 once to advance. Step 3 will flash quickly and advances to steps 13/23 very quickly. The result is RC Fan on, Pantry Air Damper on. Pantry Air Damper will open and close automatically. (13= Damper Open. 23= Damper Closed). Verify air flow inside pantry on left hand side when damper is open, (13 displayed). Air flow in pantry will cease when 23 is displayed).
- Depress SW3 to advance to last step. (04 = Both RC & FC fans on).

DIAGNOSTICS & TROUBLESHOOTING

Service Diagnostics (cont.)

Service Test - 4 Compressor/ condenser fan motor/evaporator fan

- There will be a delay of 3 seconds before start of sub step 01. Each step is timed and be automatically proceed to the next step. User will not be allowed to exit step. If exit is attempted, an invalid chime will be produced.
 - Control the Sealed System loads selecting SW3 (01 = Initialize Dual Evap Valve in home position (4min), 02 = Close both RC&FC Evap Valve (1min), 03 = Turn compressor ON (1min), 04 = Keep compressor ON, drive the valve to RC position & turn RC fan ON, 05 = Keep compressor ON, drive the valve to FC position & turn FC fan ON. Verify air flow from the evaporator fan.
- Note: Advance quickly through step 4 to keep from locking in. Once locked in you can't exit, must wait wait ten minutes approximately.

Service Test - 5 Compressor Status / Speed

- Initial Display 02 = Minimum speed
- Depress SW3. Display = 03. Compressor Ramps up to Max speed. When Max speed reached, 01 displayed.
- Depress SW3. Display = 04 Speed ramps down from Max to minimum speed. Display = 02

Service Test - 6 Defrost heater/Bi-metal

- Note: if bi-metal is open, it will need to be by-passed for heater to operate. Heater should be on. Display will be blank until a valid reading is displayed. (01 = Bi-metal closed, 02 = Bi-metal open)

Service Test - 7 Defrost mode Selection

- The defrost mode can be set by using SW3. In ADC Mode the product will automatically defrost after a minimum of 8 hours of compressor runtime up to maximum of 96 hours of compressor runtime, depending upon product usage. In Basic Mode the product will automatically defrost after 8 hours of compressor runtime. (01 = ADC ON, 02 = Basic Mode ON 8 hour timer.)

Service Test - 8 All UI indicators

- Verify that all LED indicators and UI display digits turn on automatically. All indicators ON for 30 second timeout.

Service Test - 9 UI Button and Pad Test

- Displays the user Interface Buttons and Ice and Water Pads status as described in the Component Status Indicator column,below.

NOTE: Do not use SW4 and SW5 as these are used only to navigate through the Service Diagnostics.

Press	Digit 1	Digit 2
SW1	1	
SW2	2	
SW3	3	
SW6	6	
Ice Pad		1
Water Pad		2
Ice &		3
Water Pads		

NOTE: SW4 and SW5 are used for navigation and are not displayed.

Service Test - 11 Dispenser Lighting

- Pressing SW3 will change the dispenser lighting setting from OFF (0%) to ON (100%) to DIM (50%) Status indicator is Blank

Service Test - 12 Accent Light Turns on

Service Test - 15 Ice Level Sensor

- Displays the Ice Bin Status in real time on the UI display. Verify that the full and not full levels display correctly. (01 = Bin Full, 02 = Bin Not Full)

Service Test - 16 RC Door Switch Input

- Displays the RC Door status in real time on the UI display. Verify that the open and close status display correctly. (01 = RC Door open, 02 = RC Door closed)

Service Diagnostics (cont.)

Service Test - 17 FC Door Switch Input

- Displays the FC Door status in real time on the UI display. Verify that the open and close status display correctly. (01 = FC Door Open, 02 = FC Door Closed)

Service Test - 18 Ice Door Motor

- Displays the Ice Door stepper motor state on the UI display. Press ice paddle and verify that the mechanical operation of the ice door corresponds to the component status indicator. NOTE: Ice door will have a delay in closing after an ice paddle is released. (01 = Closed, 02 = Opening, 03 = Open, 04 = Closing)

Service Test - 19 Ice Maker Fill Tube Heater and Facia Heater Status

- Control the Ice Maker Fill Tube Heater and Facia Heater selecting SW3 (toggle between On and Off) (01 = ON, 02 = OFF)

Service Test - 20 Water Filter Usage Rating

- Displays in two sequential flashes the total water usage rating in gallons for the water filter on the UI display. Wait until dash is displayed which means end of the number. (00/0- to 99/9-)

Example: 123 will be displayed as 12 3-

Service Test - 21 Water Filter Time Rating

- Displays in two sequential flashes the total time rating in days for the water filter on the UI display. Wait until dash is displayed which means end of the number. (00/0- to 99/9-) Example: 123 will be displayed as 12 3-

Service Test - 22 Water Filter Usage

- Displays in two sequential flashes the current water filter status in gallons used since last reset on the UI display. Wait until dash is displayed which means end of the number. (00/0- to 99/9-) Example: 123 will be displayed as 12 3-

Service Test - 23 Water Filter Time

- Displays in two sequential flashes the current water filter status in days since last reset on the UI display. Wait until dash is displayed which means end of the number. (00/0- to 99/9-)

Example: 123 will be displayed as 12 3-

Service Test - 24 Water Filter Reset

- Display in two sequential flashes the current times the water filter was reset on the UI display. Wait until dash is displayed which means end of the number. (00/0- to 99/9-) Example: 123 will be displayed as 12 3-

Service Test - 26 Main Control Software Version NOTE: Not normally used

- Displays in three sequential flashes the Main Control software version on the UI display. NOTE: This is repeatedly displayed during all time in this step. 00/00/00 to 99/99/99

Service Test - 27 Dispenser UI Control Software Version NOTE: Not normally used

- Displays in three sequential flashes the Dispenser UI Control software version on the UI display. NOTE: This is repeatedly displayed during all time in this step. 00/00/00 to 99/99/99

Service Test - 28 Smart Valve Software Version NOTE: Not normally used

- Displays in three sequential flashes the Smart Valve software version on the UI display. NOTE: This is repeatedly displayed during all time in this step. 00/00/00 to 99/99/99

Service Test - 29 Low Voltage IDI Software Version NOTE: Not normally used

- Displays in three sequential flashes the low voltage software version on the UI display. NOTE: This is repeatedly displayed during all time in this step. 00/00/00 to 99/99/99

Service Test - 31 Touch Input Module Software NOTE: Not normally used

- Displays in three sequential flashes the Dispenser UI Control software version on the UI display. NOTE: This is repeatedly displayed during all time in this step. 00/00/00 to 99/99/99

Service Test - 32 Ambient Thermistor UI Control

- This is an internal board test. The board will check the resistance value of the thermistor and display the results. (01 = Pass, 02 = Open, 03 = Short)

Service Test - 33 Humidity Sensor UI Control

- Relative Humidity Test (Humidity % Value 0-99 = pass or Er = Fail)

Service Test - 34 Vertical Mullion Heater Mode

- Set the Vertical Mullion Heater Sensor Mode by selecting SW3. (01 = Sensor Operation On, 02 = Sensor Operation Off) (Heater on 100%)

Service Test - 35 Vertical Mullion Heater Status

- Control the Vertical Mullion Heater selecting SW3 (toggle between On and Off) (01 = ON, 02 = OFF)

DIAGNOSTICS & TROUBLESHOOTING

Service Diagnostics (cont.)

Service Test - 36 Ice Box Fan

- Check for fan operation. Control Ice Box Fan using SW3. Display the status on Temp Display. (01 = ON, 02 = OFF). Verify air flow from the IB fan.

Service Test - 37 Ice Box Thermistor

- The board will check the resistance value of the thermistor and display the results on the Temp Display (01 = Pass, 02 = Open, 03 = Short)

Service Test - 38 Forced Defrost mode

- Set the Forced Defrost Mode by selecting SW3. OF = No Forced Defrost, Sh = Short Defrost, Lo = Long Defrost

Service Test - 39 RC Evap Thermistor

- The board will check the resistance value of the thermistor and display the results on the Temp Display. (01 = Pass, 02 = Open, 03 = Short)

Service Test - 42 UI EEPROM Control Software Version NOTE: Not normally used

- Displays in three sequential flashes the Dispenser UI Control software version on the UI display.

NOTE: This is repeatedly displayed during all time in this step. 00/00/00 to 99/99/99

Service Test - 43 UI FLASH Control Software Version NOTE: Not normally used

- Displays in three sequential flashes the Dispenser UI Control software version on the UI display.

NOTE: This is repeatedly displayed during all time in this step. 00/00/00 to 99/99/99

Service Test - 45 Ice Maker Water Fill Test

NOTE: BEFORE INITIATING THIS TEST, GO TO STEP 57, INITIATE ICE MAKER HARVEST TO INSURE ALL ICE IS EJECTED FROM MOLD BEFORE FILLING.

- After an initial 3 second delay, displays the Ice Maker water fill state on the UI display. Press SW3 to start awater fill. Pressing SW3 will toggle between ON and PAUSE. (02 = Off, 03 = On, 04 = Paused

Service Test - 46 Water dispensing Test

- Displays the status of the water dispense valve. Press the water pad to initiate a water dispense. (00 = Water Dispense Valve Off, 01 = Water Dispense Valve On)

Service Test - 56 Ice Maker Error Codes

- Displays active Ice Maker Error Codes on the UI display. (E0 = No Errors, E1 = No Cooling, E2 = Motor Lost Position, E3 = Heater Timeout, E4 = Dry Cycle, E5 = Timed Ice Making)

Service Test - 57 Ice Maker Harvest

- Press SW3 to activate a Harvest sequence. Digit 1 displays the state of the sequence. Digit 2 displays the outcome of the sequence. Once initiated, the sequence cannot be exited.

Digit 1 0 = Heater and Motor OFF, 1 = IM Heater ON, 2 = Motor Rotating CW until it finds home position

Digit 2 0 = In Progress, 1 = Harvesting Completed, 2 = Harvesting Not Completed, Doors must be closed.

NOTE: Harvesting Not Completed does not exit the step, but indicates the timeout of 70 seconds has passed.

Service Test - 58 Ice Maker Heater Activation and Thermistor

- Press SW3 to activate the Ice Maker Heater and to toggle between On and Off. Digit 1 displays the state of the heater. Digit 2 displays the thermistor state.

Digit 1 0 = IM Heater OFF, 1 = IM Heater ON

Digit 2 0 = Temp warmer than harvest temp, 1 = Temp cooler than harvest temp, 2 = Open, 3 = Short

Service Test - 59 Ice Maker Motor

- Press SW3 to activate a Motor sequence and toggle through each step. Digit 1 displays the state of the motor. Digit 2 displays the status of the motor. Once initiated, the sequence cannot be exited.

Digit 1 0 = Motor OFF, 1 = Motor Rotating CW until home position, 2 = Motor OFF, 3 = Motor Rotating CCW until home position

Digit 2 0 = In Progress, 1 = Harvesting Completed, 2 = Harvesting Not Completed

NOTE: Harvesting Not Completed does not exit the step, but indicates the timeout of 70 seconds has passed.

Service Test - 60 Pantry UI Software Version NOTE: Not normally used

- Displays in three sequential flashes the Pantry UI Control software version on the UI display.

NOTE: This is repeatedly displayed during all time in this step. 00/00/00 to 99/99/99

Service Test - 61 Pantry Touch Input Module Software NOTE: Not normally used

- Displays in three sequential flashes the Pantry UI Control software version on the UI display.

NOTE: This is repeatedly displayed during all time in this step. 00/00/00 to 99/99/99

Service Diagnostics (cont.)

Service Test - 62 Pantry Lighting (On Some Models)

- Pressing SW3 will change the pantry lighting setting from OFF (0%) to ON (100%). (00 = OFF, 01 = ON).

Service Test - 63 All Pantry UI indicators

- Verify that all pantry LED indicators and pantry UI display digits turn on automatically. All indicators ON for 30 second timeout.

Service Test - 64 Pantry UI Button Test

- Displays the pantry UI Buttons status.

Press	Digit 1	Digit 2
SW1	0	1
SW2	0	2
SW3	0	3
SW4	0	4
SW5	0	5

FN25 and FN 54	
Label	Control key
Preset	SW703
“+”	SW704
“-”	SW705

FN25 and FN 54	
Label	Control key
Meat/Poultry	SW701
Cold Drinks	SW702
Deli/Cheese	SW703

Service Test - 65 Pantry thermistor

- The board will check the resistance value of the thermistor and display the results on the Temp Display (01 = Pass, 02 = Open, 03 = Short)

Service Test - 66 Manufacturing Codes

- Displays the active manufacturing errors codes stored in the UI. Press SW3 to toggle between the Errors. See status on Temp Display (E0 = No Error, E1 = LPIM Motor Faulty, E2 = Damper Cycle not completed, E3 = Thermistor Faulty, E4 = Ice Bin not present or Full, E5 = Heater Bimetal Faulty, E6 = Dispenser UI EEPROM Faulty, Er = Communication Failure).

NOTE: Step is used by Whirlpool Manufacturing plant only.

Service Test - 67 Water Filter Switch Status

- Displays the water filter switch status in real time on the UI display. Verify that the open and close status display correctly. (01 = Switch open, filter installed, 02 = Switch closed, filter not installed)

Service Test - 73 Pantry Heater Status

- Control the Pantry Heater selecting SW3 (toggle between On and Off) (01 = ON, 02 = OFF)

DIAGNOSTICS & TROUBLESHOOTING

Service Diagnostics (cont.)

Schematic - French Door Bottom Mount Dual Evaporator Refrigerator With Smart Valve

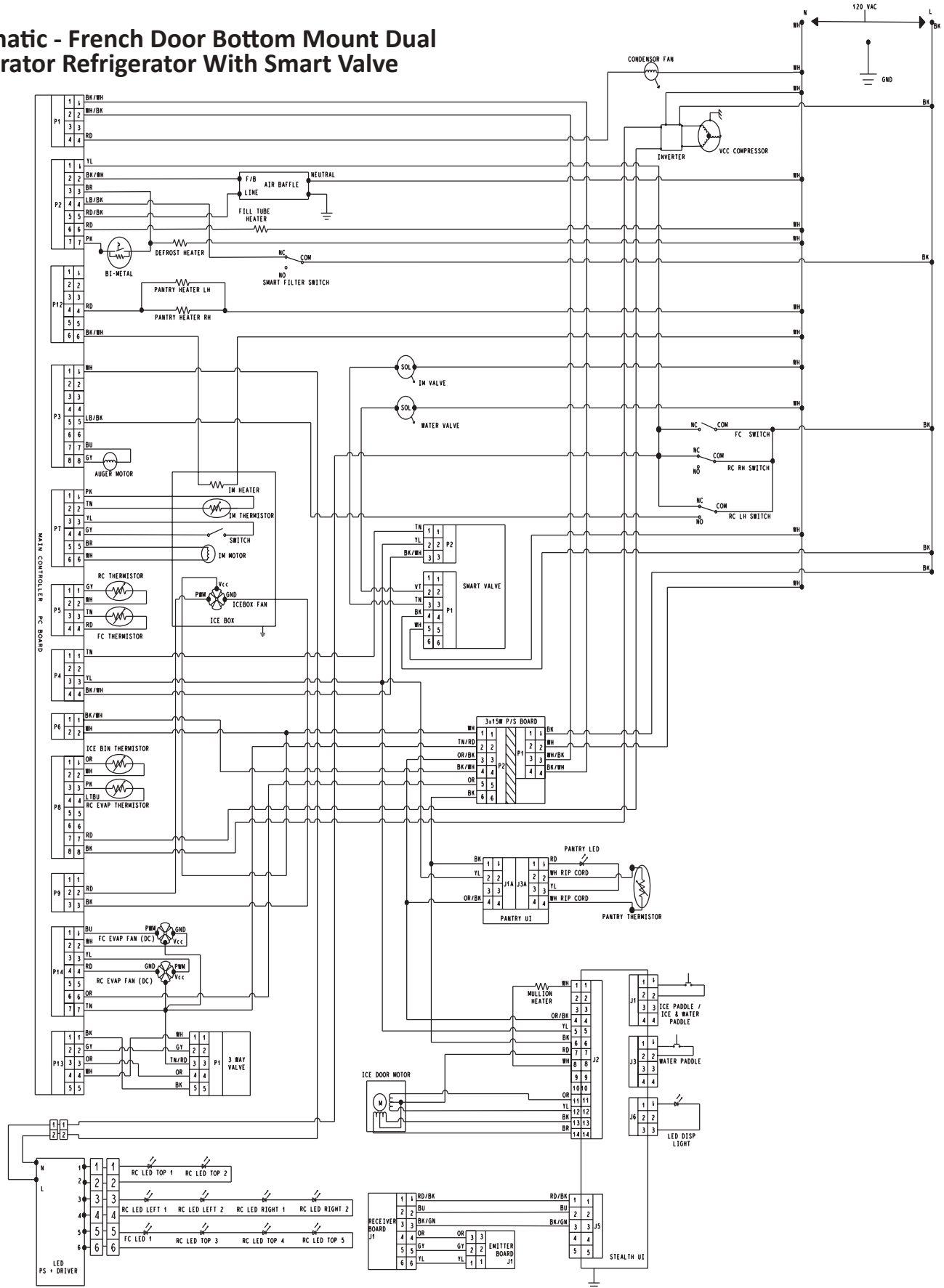

Troubleshooting

Troubleshooting Noise Complaints

A new refrigerator design with new components also involves new and different operating noises. These noises can drive a service call when there is not a problem. Noise can normally be traced to one of the motors or rotary refrigerant valve used on some models. This section is focused on isolating the root cause of the operating noise and determining if the noise is normal. If the noise is abnormal, recommend a path to resolution.

Dual Evaporator Procedure:

Troubleshooting noise complaints on 36" wide dual evaporator FDBM refrigerator models using the technical data sheet and this supplement as a guide.

The following information is comprised of excerpts from the original Technical Data Sheet shipped with the refrigerator. Always refer to the TDS shipped with the refrigerator you are servicing for information specific to that model.

Ask the customer to be present for the test so they can verify the noise they find objectionable. Follow the instructions below to enter each applicable step to energize specific motors.

Note: Follow the Safety Warnings included with the Technical Data Sheet

TO ENTER SERVICE DIAGNOSTICS Mode:

Press SW1 and SW2 simultaneously for 3 seconds. Release both buttons when you hear the CHIME indicator. Unit must not be in Lockout prior to entering SERVICE DIAGNOSTIC MODE.

The display will show 01 to indicate the control is in step 1 of the diagnostics routine. Each step must be manually advanced. Press SW5 to move to the next step in the sequence. Press SW4 to back up in the sequence to the previous step. Diagnostics will begin at Step 1. Each step is displayed in the two digits of the dispenser user interface display. The step results are displayed in the two digits on dispenser user interface display 2 seconds after the step number is displayed. An amber order filter light will be shown to designate that the step number is being displayed and a red replace filter light will be shown to designate that the status of the step is being displayed. All button and pad inputs shall be ignored and all inputs shall be off except as described in the actions for each step.

To test for RC and FC evaporator fan motor for noise issues, use service test 3.

Service Test - 3 Evaporator fan motor and air baffle motor

- Control the RC & FC Evaporator Fan Motors by depressing SW3 (01= Both Fan Motors off. 02 =FC Fan on.)

If the customer is present, ask them to verify whether the FC fan motor operation is the noise they find objectionable. If yes and the noise is normal, instruct customer. If the noise is not normal, proceed to eliminate any possibility of the noise being caused by vibration or interference with adjacent components before replacing the FC motor.

If No, proceed:

- Depress SW3 once to advance. Step 3 will flash quickly and advances to steps 13/23 very quickly. The result is RC Fan on, Pantry Air Damper on. Pantry Air Damper will open and close automatically. (13= Damper Open.23= Damper Closed). Verify air flow inside pantry on left hand side when damper is open, (13 displayed). Air flow in pantry will cease when 23 is displayed).

- Depress SW3 to advance to last step. (04 = Both RC & FC fans on).

If the customer is present, ask them to verify whether the RC fan motor operation is the noise they find objectionable. If yes and the noise is normal, instruct customer. If the noise is not normal, proceed to eliminate any possibility of the noise being caused by vibration or interference with adjacent components before replacing the RC motor.

DIAGNOSTICS & TROUBLESHOOTING

Troubleshooting (cont.)

If No, proceed:

To test the Compressor and Condenser Fan Motor for noise issues use service test 4

Service Test - 4 Compressor/ condenser fan motor/evaporator fan.

- There will be a delay of 3 seconds before start of sub step 01. Each step is timed and will automatically step to the next step. User will not be allowed to exit step. If exit is attempted, an invalid chime will be produced.
- Control the Sealed System loads selecting SW3 (01 = Initialize Dual Evaporator Valve in home position (4min), 02 = Close both RC&FC Evaporator Valve (1min), 03 = Turn compressor ON (1min), 04 = Keep compressor ON, drive the valve to RC position & turn RC fan ON, (2min), 05 = Keep compressor ON, drive the valve to FC position & turn FC fan ON. Verify air flow from the evaporator fan.

If the customer is present, ask them to verify whether the compressor or condenser fan motor operation is the noise they find objectionable. If yes and the noise is normal, instruct customer. If the noise is not normal, proceed to eliminate any possibility of the noise being caused by vibration or interference with adjacent components before replacing the faulty component.

NOTE: Once locked in to step 4, you can't exit, you must wait approximately 10 minutes.

If No, proceed:

To test for Compressor noise issues during Compressor ramp up, use service test 5.

Service Test - 5 Compressor Status/Speed

- Initial Display 02 = Minimum speed
- Depress SW3. Display = 03. Compressor Ramps up to Max speed. When Max speed reached, 01 displayed.
- Depress SW3. Display = 04 Speed ramps down from Max to minimum speed. Display = 02.

If the customer is present, ask them to verify whether the compressor ramp up operation is the noise they find objectionable. If yes and the noise is normal, instruct customer. If the noise is not normal, proceed to eliminate any possibility of the noise being caused by vibration or interference with adjacent components before replacing the compressor.

If No, proceed:

To test the Ice Maker fan for noise issues, use service test 36.

Service Test - 36 Ice Box Fan

- Check for fan operation. Control Ice Box Fan using SW3. Display the status on Temp Display. (01 = ON, 02 = OFF). Verify air flow from the IB fan.

If the customer is present, ask them to verify whether the Ice Box Fan operation is the noise they find objectionable. If yes and the noise is normal, instruct customer. If the noise is not normal, proceed to eliminate any possibility of the noise being caused by vibration or interference with adjacent components before replacing the fan.

If No, proceed:

To test the Ice Maker motor for noise, use service test 59.

Service Test - 59 Ice Maker Motor

- Press SW3 to activate a Motor sequence and toggle through each step. Digit 1 displays the state of the motor. Digit 2 displays the status of the motor. Once initiated, the sequence cannot be exited. Digit 1 0 = Motor OFF, 1 = Motor Rotating CW until home position, 2 = Motor OFF, 3 = Motor Rotating CCW until home position Digit 2 0 = In Progress, 1 = Completed, 2 = Homing Not Complete (*See step 57)
*NOTE: Harvesting Not Completed does not exit the step, but indicates the timeout of 70 seconds has passed.

If the customer is present, ask them to verify whether the Ice Maker operation is the noise they find objectionable. If yes and the noise is normal, instruct customer. If the noise is not normal, replace the ice maker.

Troubleshooting (cont.)

⚠ WARNING



Electrical Shock Hazard
Disconnect power before servicing.
Replace all parts and panels before operating.
Failure to do so can result in death or electrical shock.

⚠ DANGER



Electrical Shock Hazard
Only authorized technicians should perform diagnostic voltage measurements.
After performing voltage measurements, disconnect power before servicing.
Failure to follow these instructions can result in death or electrical shock.

Voltage Measurement Safety Information

When performing live voltage measurements, you must do the following:

- Verify the controls are in the off position so that the appliance does not start when energized.
- Allow enough space to perform the voltage measurements without obstructions.
- Keep other people a safe distance away from the appliance to prevent potential injury.
- Always use the proper testing equipment.
- After voltage measurements, always disconnect power before servicing.

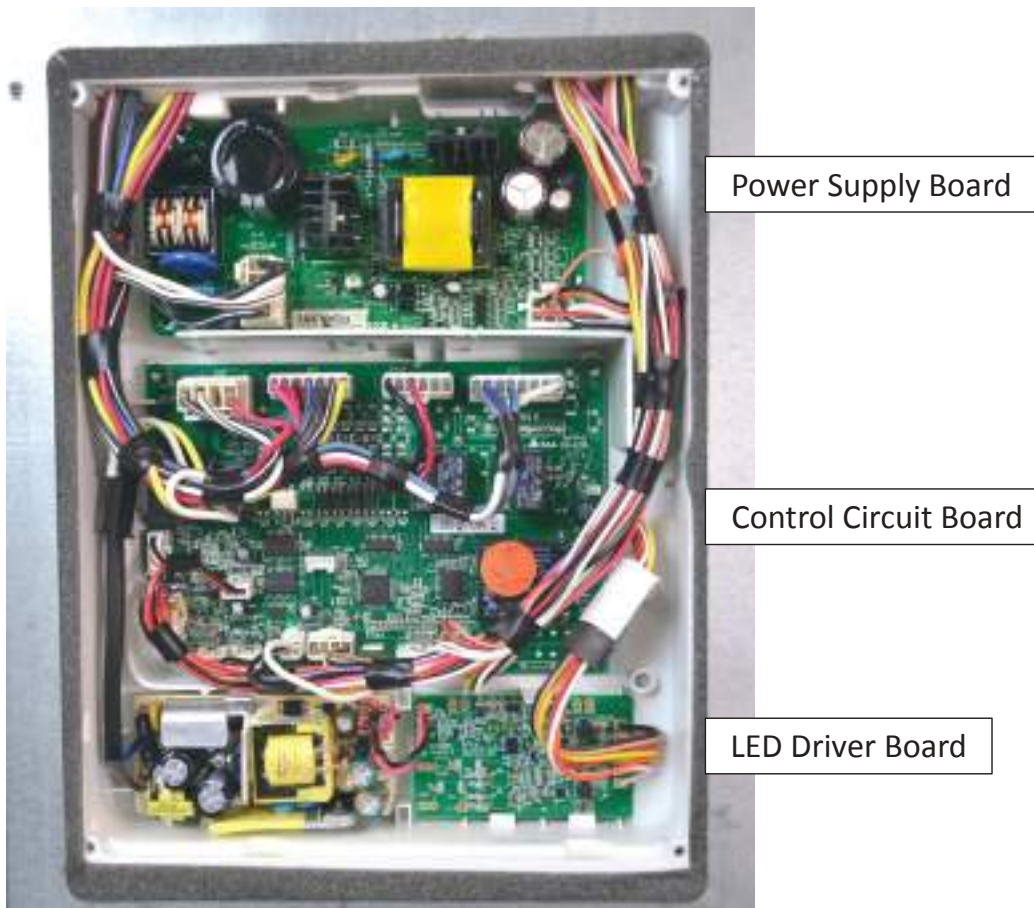

DIAGNOSTICS & TROUBLESHOOTING

Troubleshooting (cont.)

Power Supply Board

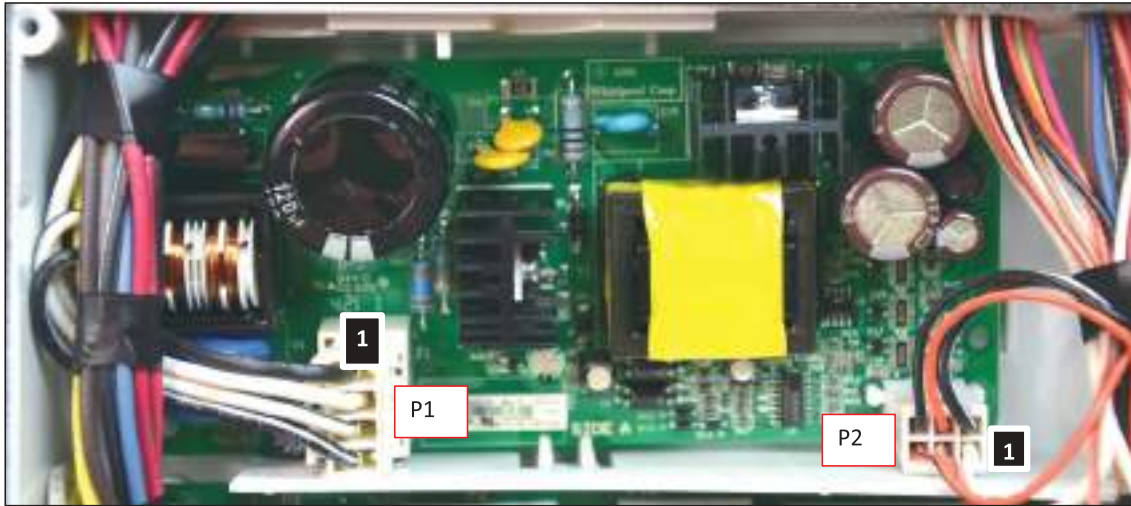

		FROM	TO	VOLTAGE	CONDITIONS
POWER SUPPLY	P1	P1-1	P1-2	115VAC	Constant 115 VAC
		P1-3	P1-4		Constant 115 VAC
	P2	P2-1	P2-4	14VDC	Constant 14VDC
		P2-2	P2-5		Constant 14VDC
		P2-3	P2-6		Constant 14VDC

Troubleshooting (cont.)

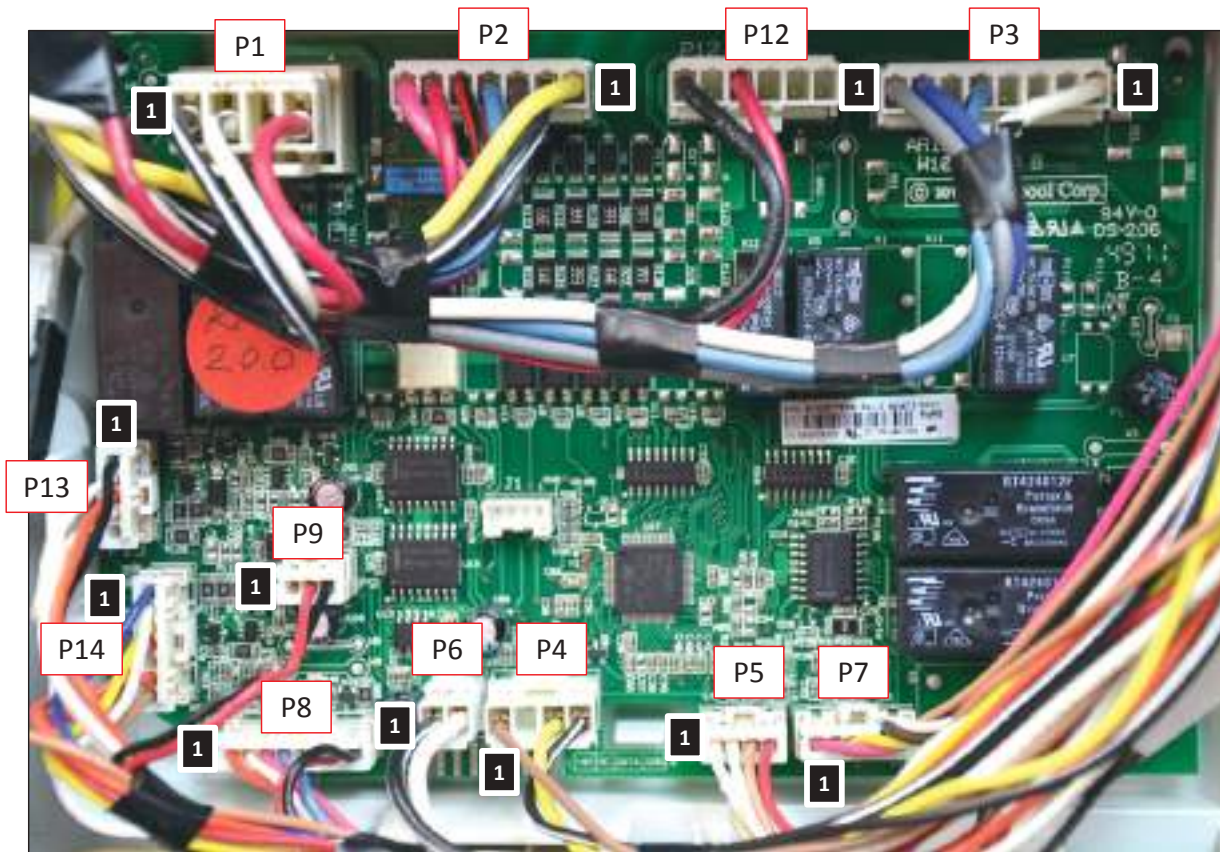

This picture identifies the location of the control board pin connectors. Refer to the tech sheet that's packed with the product.

DIAGNOSTICS & TROUBLESHOOTING

Troubleshooting (cont.)

Control Board

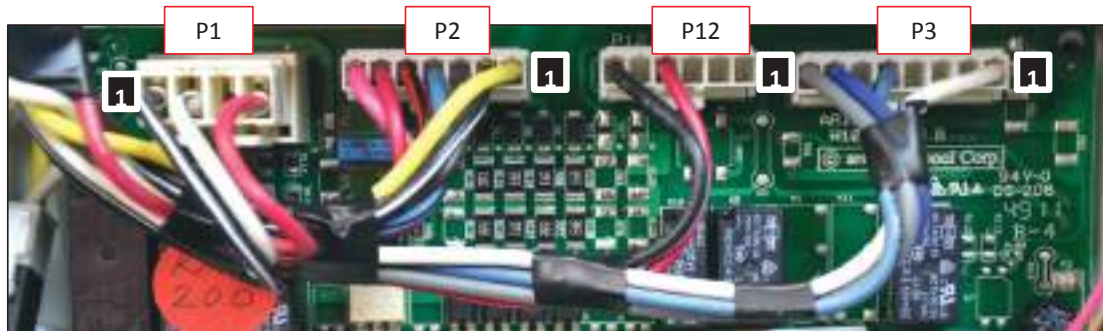

P1	P1-1	P1-2	115VAC	Constant 115VAC
	P1-2	P1-4		Constant 115VAC
P2	P2-1	P1-2	115VAC	RC or FC Door open 115V. Doors Closed = 0V
	P2-2	P1-2		Air Baffle feedback. Activate Service Test 3, Step 3
	P2-3	P1-2		Heater, Bi-Metal bypass. Service Test 6. 115V if Bimetal closed.
	P2-4	P1-2		Water Filter removed 115V. Filter Installed 0V
	P2-5	P1-2		Air Baffle output. Activate Service Test 3, Step 3
	P2-6	P1-2		Fill Tube heater output. Service Test 19. 01=115v, 02=0v
P12	P12-4	P1-2	115VAC	Pantry heater output. Test 73. 01=115VAC
	P12-6	P1-2		IM heater output. Test 58. SW3 to activate 01= 115VAC
P3	P3-1	P2-1	115VAC	RC or FC Door open 115V. Doors Closed = 0V
	P3-5	P1-2		Left RC door must be closed =115V. Open= 0V
	P3-7	P3-8	130VDC	Auger output. LH RC door Closed, Activate Ice Paddle = 130-140VDC

LED Driver Board



120 VAC

Troubleshooting (cont.)

Control Board

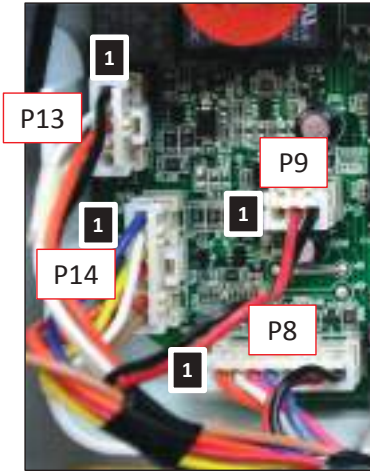

P13	P13-1	P13-2		3way refrigerant valve, Cannot check voltage output
	P13-3	P13-4		3way refrigerant valve, Cannot check voltage output
P-14	P14-1	P14-2	14 VDC	FC Fan Motor Output. Activate Service Test 3, step 2
	P14-3	P14-4		RC Fan Motor Output. Activate Service Test 3, step 3
	P14-7	P14-6		Constant 14VDC

P9	P9-2	P9-3	14 VDC	Icebox fan output. Test 36. SW3 to activate. 01=14VDC
----	------	------	--------	---

P8	P8-1	P8-2	5VDC	Ice Bin Thermistor output = 1.5-5.0 VDC
	P8-3	P8-4		RC Evap. thermistor output = 1.5-5.0 VDC
	P8-7	P8-8	3-6VDC	Inverter output 3-6 VDC Constant

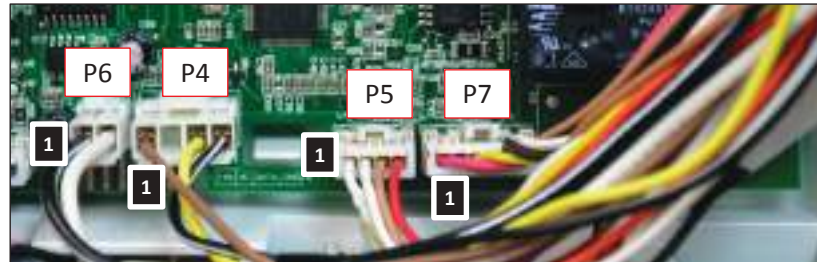

J6	J6-1	J6-3	14VDC	Dispenser light on.
----	------	------	-------	---------------------

P4	P4-1	P4-4	14 VDC	Constant 14VDC
	P4-3	COMMUNICATION		Cannot be checked



P5	P5-1	P5-2	5VDC	RC thermistor output = 1.5-5.0 VDC
	P5-3	P5-4		FC thermistor output = 1.5-5.0 VDC
P7	P7-1	P7-2	5VDC	IM thermistor output = 1.5-5.0 VDC
	P7-5	P7-6	14VDC	IM Motor Output. Test 57, SW3 to activate. Up to 2min delay

Section 7: Refrigerant Recovery and Charging Procedures

This section provides service parts access, removal and Installation information concerning KitchenAid, Maytag and Whirlpool dual evaporator French Door Refrigerators.

- Representative Examples of Equipment, Tools and Supplies
- Equipment, Tools and Supplies
- Key Components
- Phase One: Initial Hook Up
- Phase Two: Refrigerant Recovery
- Phase Three: Make Repairs
- Phase Four: Evacuation
- Phase Five: Charging

Sealed System Repair

 WARNING

<p>Electrical Shock Hazard Disconnect power before servicing. Replace all parts and panels before operating. Failure to do so can result in death or electrical shock.</p>

Sealed System Repair (cont.)

Representative Examples of Equipment, Tools and Supplies:



Equipment, Tools and Supplies:

- Recovery pump
- 134A Recovery Cylinder
- UV Drier
- Schrader Valve Extractor and Extra Valves
- Tubing cutters
- Process tube with schrader valve
- 4 port manifold gauge set
- Sandpaper
- Charging hoses
- Micron Vacuum Gauge and Copper "T fitting for Micron gauge
- 1/4" and 5/16" Swedges
- 4 Hand valves
- Brazing alloy and Flux
- Acetylene torch
- Welding/Brazing blanket
- Fire Extinguisher
- Heated charging cylinder
- 1/2" wrench, 7/16" wrench, Pliers, Triangle File and Assorted hand Tools
- Temporary access Valves
- High Capacity dual stage Vacuum pump (4 cf. or greater)
- PPE - Personal Protection Equipment - Approved Eye Protection
- 134A Heated Charging Cylinder and Charging Hose or Electronic Refrigerant Scale
- VOM Multimeter and Clamp On Ammeter
- Tubing Cutters
- Heat Gun
- UV Drier with Schrader Valve
- Extension Tube with Schrader Valve (For insertion into process tube)
- Ultraviolet Light and Glasses
- Shut Off hand Valves

Sealed System Repair (cont.)

Key Components



4-Way Manifold Gauge



Shut Off Valves



Dye Drier with Shraeder Valve



Process Stub Shraeder Valve

Note: When handling refrigerant, ANSI certified Personal Eye Protection is recommended.

Note: Always follow the Manufactures' instructions shipped with tools and Equipment .

Equipment, Tools and Supplies:

Everything depicted in this process is currently used in the refrigeration industry. If you already perform sealed system repairs you may have some or all of these items . If not, this equipment is readily available from most refrigeration supply houses.

Note: There are a number of different manufactures of this equipment. Whirlpool is not endorsing specific brands.

Key Components

The key components used in this process are:

The 4 way manifold gauge set

Shut off valves

Dye drier with schrader valve

Process stub extension with schrader valve

These items are critical for accurate charging and efficiency.

Sealed System Repair (cont.)

Phase One: Initial Hook Up

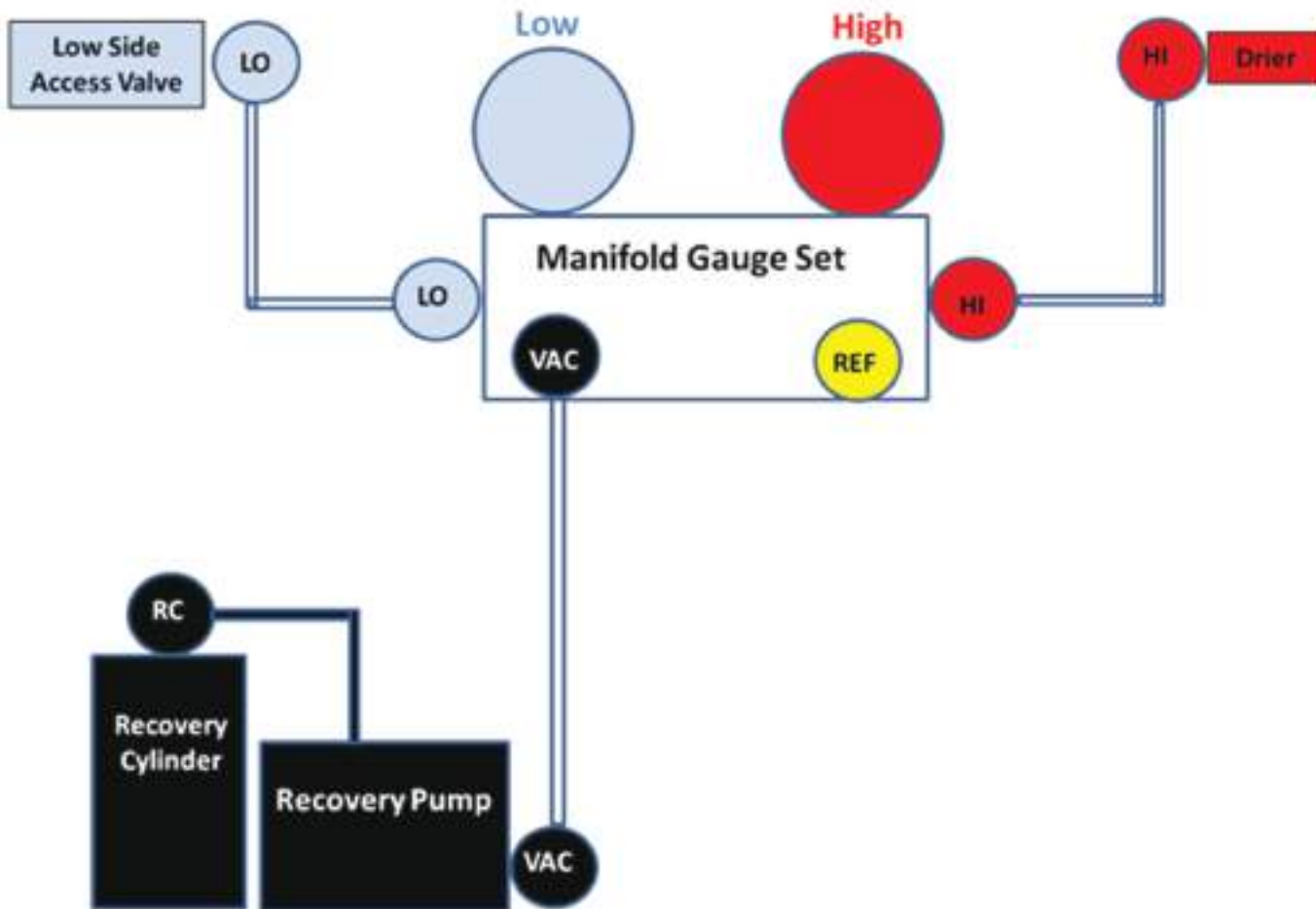

Sealed System Repair (cont.)

Phase One: Initial Hook Up

1. Verify Failure
2. (For dual evaporator products) Enter the refrigerator diagnostic service mode and advance to step 4 to insure the 3-way is open to both RC and FC capillary tubes
3. Unplug or disconnect power to refrigerator
4. Remove the machine compartment cover
5. Install High and Low side temporary access valves
6. Install shut off valves on access valves
7. Connect high side manifold gauge hose to high side shut off valve
8. Connect low side manifold gauge hose to low side shut off valve
9. Connect evacuation hose to recovery pump inlet hand valve
10. Connect hose from recovery pump outlet valve to recovery cylinder hand valve

Sealed System Repair (cont.)

Phase Two: Refrigerant Recovery

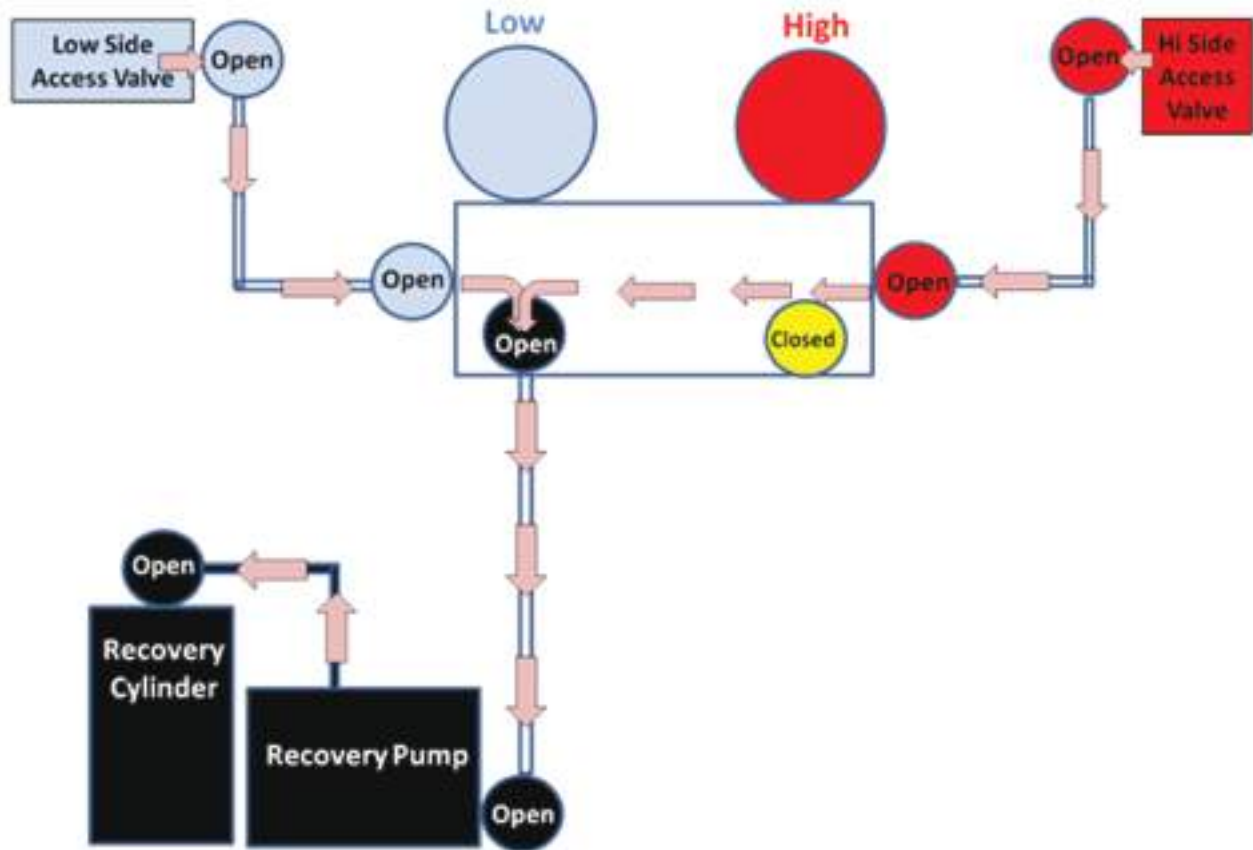

1. Start recovery pump
2. Open recovery pump inlet valve
3. Open recovery pump outlet valve
4. Open inlet valve on recovery cylinder
5. Open evacuation manifold valve
6. Open low side manifold valve
7. Open high side manifold valve
8. Open high side shut off valve
9. Open Low side shut off valve
10. Recover refrigerant from both the high and low side of the system
11. When the gauges indicate a 4" HG system vacuum has been achieved, close the recovery cylinder hand valve and shut off the recovery pump
12. Remove the high and low side hoses and shut off valves from the access valves and attach to the manifold ports

REFRIGERANT RECOVERY AND CHARGING PROCEDURES

Sealed System Repair (cont.)

Phase Three: Make Repairs

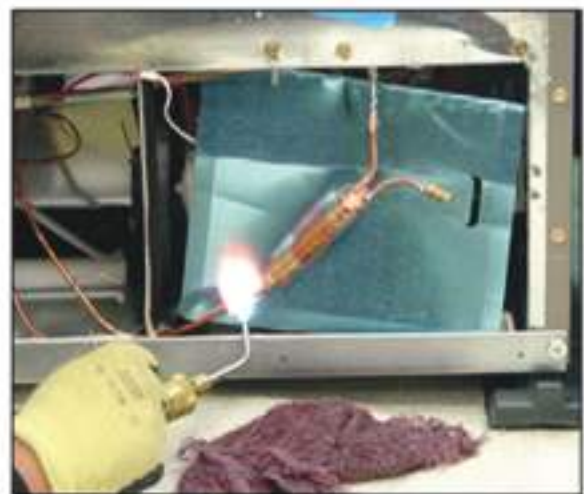
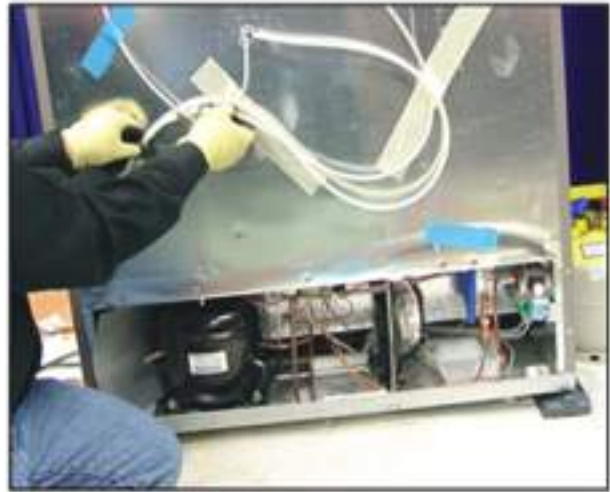

1. Remove temporary access valves
2. Remove any wiring harnesses, starting components, water tubes or related components that could be damaged during repair
3. Install heat shields to protect the refrigerator cabinet and adjacent components before brazing
4. Make necessary repairs
5. Remove schrader valve from dye drier and install drier
6. Remove schrader valve from the process stub extension tube and install (or braze on saddle valve on suction line and install)
7. After brazing is completed install the shraeder valves

Sealed System Repair (cont.)

Phase Four: Evacuation

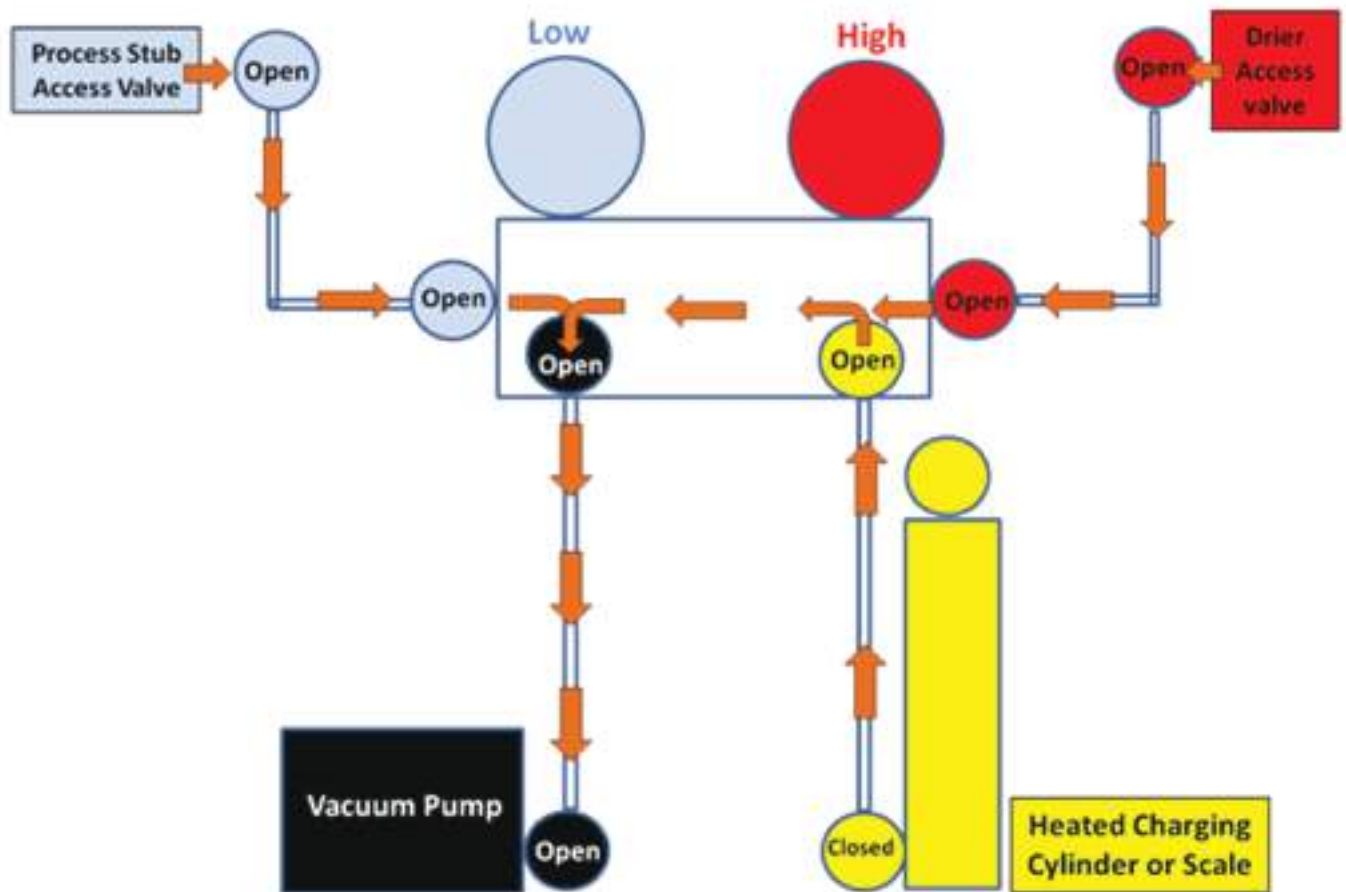

1. Connect high and low side manifold hoses to the drier and process tube shut off valves
2. Connect a hose from evacuation manifold gauge valve to the inlet of the vacuum pump
3. Fill the charging cylinder with an additional ounce of R134A than is listed on the model number plate and plug in the cylinder. Heat the refrigerant until the pressure is 30# higher than the equivalent ambient pressure would be.
4. Connect a hose from the charging cylinder to the Refrigerant port on the manifold
5. Close all valves
6. Start the vacuum pump
7. Open the inlet valve on the vacuum pump
8. Open the VAC valve on the manifold
9. Open the REF valve on the manifold

REFRIGERANT RECOVERY AND CHARGING PROCEDURES

Sealed System Repair (cont.)

Phase Four: Evacuation (continued)

10. Open the high side manifold valve
11. Open the high side shut off valve
12. Open the low side manifold valve
13. Open the low side shut off valve
14. Evacuate from both the high and low side of the system

Note: If the evaporator is cold open the door and allow to warm or use a heat gun to heat the evaporator

Maintain 28" HG vacuum for 5 minutes

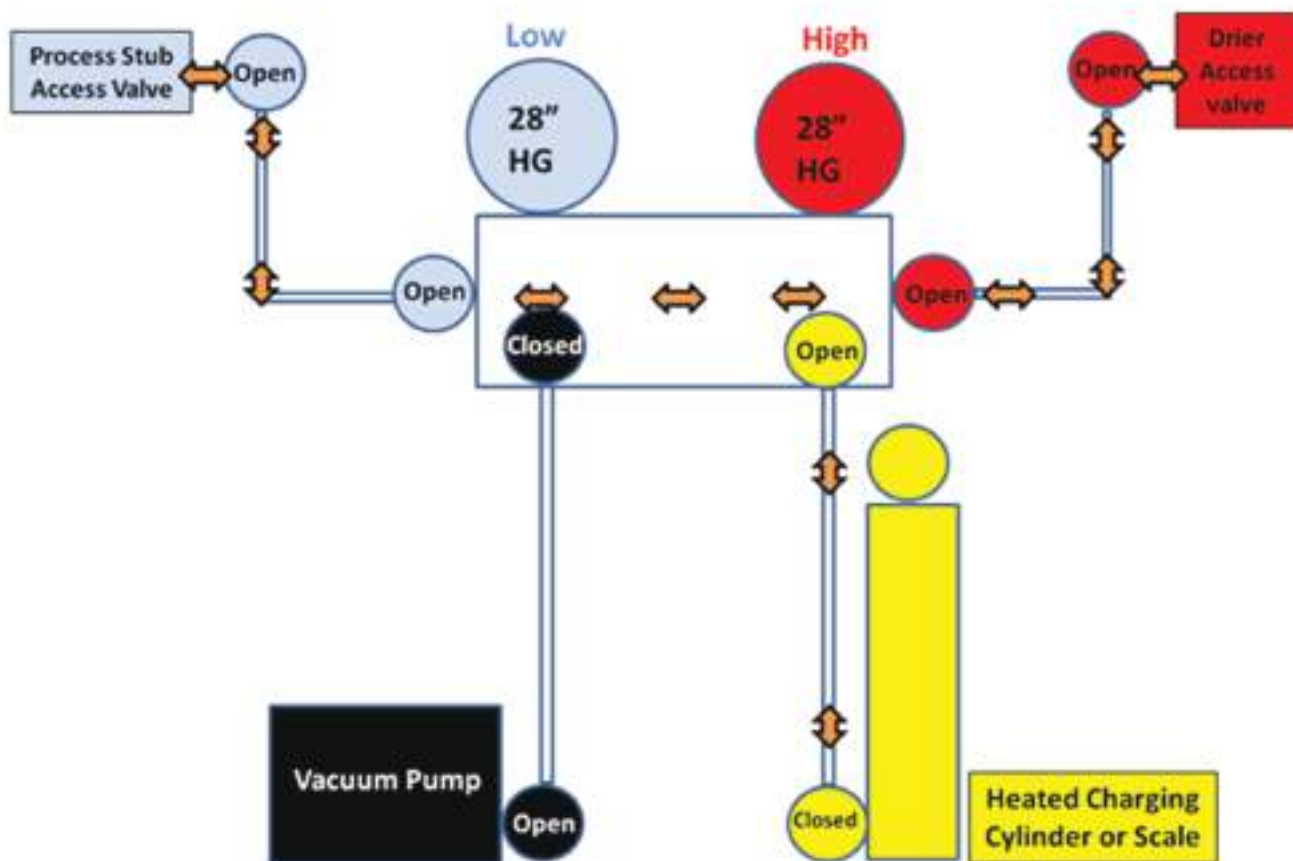

15. Evacuate the system until the pressure drops to a minimum of 28" HG.
16. Close the VAC valve
17. The 28" HG vacuum should remain constant – any increase in pressure indicates moisture in the system or a system or equipment leak
18. If the vacuum remains at a minimum of 28" HG for 5 minutes proceed to the charging phase

Sealed System Repair (cont.)

Phase Five: Charging

1. Set the barrel on the charging cylinder to align with the refrigerant pressure
2. Subtract the refrigerant system charge from the amount of refrigerant in the cylinder and mark the level using a rubber band on the barrel
3. Open the charging cylinder hand valve and dump in the refrigerant into both the high and low side of the system. Stop when the exact charge has been added.

Removing refrigerant from hoses

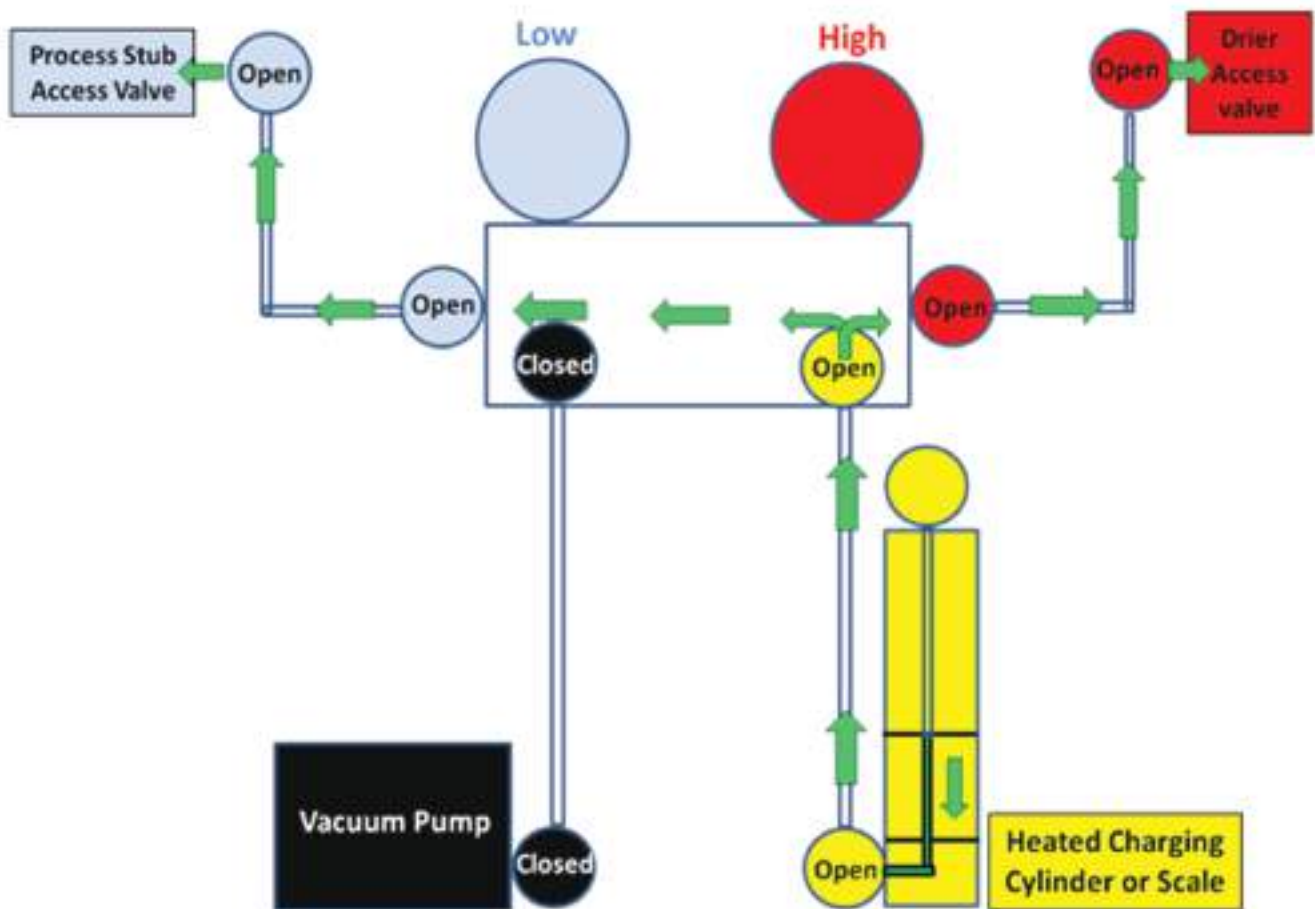

Sealed System Repair (cont.)

Phase Five: Charging (continued)

Phase Five: Evacuation , Leak Checking and Return to Service

4. Close the high side shut off hand valve connected to the drier and the low side shut off hand valve
5. Plug in the refrigerator and start the compressor and let the compressor run for 1 minute
6. Crack open the low side shut off valve and remove all the refrigerant remaining in the hoses
7. When the low side pressure drops to "0" shut off:
REF valve on manifold
High side valve on manifold
Low side valve on manifold
Low side shut off hand valve
8. Unplug the refrigerator and remove the high and low side shut off valves
9. Install silicone tape to shraeder valve threads and install caps.
10. Wait a minimum of 2 minutes and use soap bubble solution to check all high side connections first and then check the low side connections.
11. Plug in the refrigerator and start the compressor
12. The system is fully charged and will begin cooling. Check for heat at the compressor discharge line and then the heat loop. Check for cool air from the evaporator
13. Once it has been determined the unit is cooling unplug the refrigerator.
14. Install all machine compartment components and the cover
15. Plug in the refrigerator and set temperature
16. Instruct customer

NOTES

PRODUCT SPECIFICATIONS & WARRANTY INFORMATION SOURCES

IN THE UNITED STATES:

FOR PRODUCT SPECIFICATIONS AND WARRANTY INFORMATION CALL:

FOR WHIRLPOOL PRODUCTS:	1-800-253-1301
FOR KITCHENAID PRODUCTS:	1-800-422-1230
FOR ROPER PRODUCTS:	1-800-447-6737

FOR TECHNICAL ASSISTANCE WHILE AT THE CUSTOMER'S HOME CALL:

THE TECHNICAL ASSISTANCE LINE: 1-800-832-7174

**HAVE YOUR STORE NUMBER READY TO IDENTIFY YOU AS AN
AUTHORIZED IN-HOME SERVICE PROFESSIONAL**

FOR LITERATURE ORDERS:

PHONE: 1-800-851-4605

FOR TECHNICAL INFORMATION AND SERVICE POINTERS:

www.servicematters.com

IN CANADA:

FOR PRODUCT SPECIFICATIONS AND WARRANTY INFORMATION CALL

1-800-461-5681

FOR TECHNICAL ASSISTANCE WHILE AT THE CUSTOMER'S HOME CALL:

THE TECHNICAL ASSISTANCE LINE: 1-800-488-4791

**HAVE YOUR STORE NUMBER READY TO IDENTIFY YOU AS AN
AUTHORIZED IN-HOME SERVICE PROFESSIONAL**

