

# SAMSUNG

# REFRIGERATOR

## FRENCH DOOR REFRIGERATOR

MODEL NAME : RF18A\*

MODEL CODE : RF18A5101\*\* RF49A5002\*\*  
RF20A5101\*\* RF57A5002\*\*  
RF50A5002\*\* RF49A5102\*\*  
RF44A5002\*\* RF49A5202\*\*  
RF50A5202\*\* RF57A5032\*\*  
RF5GA5202\*\* RF57A5232\*\*  
RF57B5132\*\*

# *SERVICE* Manual

## REFRIGERATOR



RF18A51\* RF49A50\*  
RF20A51\* RF49A51\*  
RF44A50\* RF57A50\*  
RF50A50\* RF57A52\*

RF44A52\*  
RF50A52\*  
RF49A52\*

## CONTENTS

1. PRODUCT INFORMATION.....	5
2. PRODUCT SPECIFICATIONS.....	9
3. FUNCTIONS & FEATURES.....	26
4. DISASSEMBLY AND REASSEMBLY .....	28
5. CHECK THE INSTALLATION STATUS.....	63
6. SELF DIAGNOSIS & TROUBLE SHOOTING.....	86
7. PCB DIAGRAM.....	101
8. WIRING DIAGRAM.....	103
9. BLOCK DIAGRAM.....	104
10. REFERENCE INFORMATION .....	105



## WARNING

### IMPORTANT SAFETY NOTICE

The service guide is for professional repairers who have technical competence to repair refrigerating appliances and comply with all applicable regulations for repairers of electrical equipment.

Any attempt to repair the appliance by a non-professional repairer may result in personal injury and property damage.

The manufacturer or dealer will not be held responsible for the interpretation of this information.

All rights reserved. This service guide may not be reproduced in whole or as a part in any form whatsoever without the written permission of the SAMSUNG ELECTRONICS Company.

Samsung is not liable for any damage to product, any injury or any other product safety issue caused by any attempt to repair the product which does not carefully follow these repair and maintenance instructions or carried out by a non-authorized service provider, self-repair or non-professional repair of the product, Any damage to the product caused by an attempt to repair the product by any person other than a Samsung authorises service provider will not be covered by the warranty.

For information about purchasing parts and tools, please visit <http://samsung.com/support>

SAMSUNG ELECTRONIC, INC.  
Technical Service Guide  
Copyright ©2020

# Contents

<b>1. Product Information .....</b>	<b>5</b>
<b>2. Product Specifications .....</b>	<b>9</b>
2-1) Introduction of Main Function .....	9
2-2) Interior Views .....	10
2-3) Model Specification & Specification Chart .....	11
2-4) Dimensions of Refrigerator (Inches) .....	19
2-5) Optional Material Specification .....	20
2-6) Refrigerant Route in Refrigeration cycle .....	21
2-7) Principle Of Freezer .....	22
2-8) Operation theory of refrigeration cycle components .....	23
2-9) Refrigeration Cycle Type .....	25
2-10) Cooling Air Circulation .....	25
<b>3. Functions &amp; Features .....</b>	<b>26</b>
3-1) Control Display .....	26
<b>4. Disassembly and Reassembly .....</b>	<b>28</b>
4-1) Precaution .....	28
4-2) Refrigerator Door (Hinge Up) .....	29
4-3) Refrigerator Door (Hinge Mid) .....	30
4-4) Refrigerator Door (Hinge Up) .....	31
4-5) Freezer Door .....	32
4-6) Gasket .....	33
4-7) Freezer Door Switch .....	34
4-8) Refrigerator Light .....	35
4-9) TOP TABLE (With Sensor Temp) .....	37
4-10) Freezer Light .....	38
4-11) Glass shelves .....	39
4-12) Drawer .....	39
4-13) Door Bins .....	42
4-14) COVER EVAP-REF .....	43
4-15) COVER EVAP-REF (With Sensor Temp) .....	44
4-16) Evaporator REF .....	46
4-17) Evap (Sensor) REF .....	47
4-18) COVER EVAP-FRE .....	48
4-19) Evaporator FRE .....	49
4-20) Evap (Sensor Temp) FRE .....	50
4-21) Ice Maker (Freezer) (OPTION) .....	51
4-22) Water Dispenser (OPTION) .....	52
4-23) Water Tank (OPTION) .....	53
4-24) Sensor In Freezer .....	54
4-25) Comp Cooling Fan .....	56
4-26) Compressor .....	57
4-27) Machine Compartment .....	59
4-28) Electric Box (PBA Main) .....	60
4-29) Electric Box (PBA Main) .....	61
4-30) Electric Box (Fuse Block) .....	61
4-31) Cover-Display .....	62

# Contents

<b>5. Check the installation status .....</b>	<b>63</b>
5-1) Function for failure diagnosis .....	63
5-1-1. Test mode (manual operation / manual defrost function).....	63
5-1-2. Self-diagnostic function .....	67
5-1-3. Display function of Load condition .....	73
5-1-4. DEMO MODE 1 : Cooling OFF Mode setting function (North America model).....	75
5-1-5. DEMO MODE 2 : Exhibition Mode setting function (All regions except for North America).....	76
5-1-6. Option setting function .....	77
5-1-7. Option TABLE .....	81
5-2) Diagnostic method according to the trouble symptom (Flow Chart).....	84
<b>6. Self Diagnosis &amp; Trouble Shooting.....</b>	<b>86</b>
6-1) If the trouble is detected by self-diagnosis .....	86
6-2) IF FAN does not operate .....	89
6-3) When ICE MAKER(FZ) does not operate (OPTION) .....	91
6-4) If defrost does not operate (F/R DEF Heater).....	92
6-5) When Power is not applied .....	93
6-6) When Compressor does not run (Inverter COMP.) .....	94
6-7) When alarm sounds continuously without stop (related with buzzer sound) .....	95
6-8) When the Inner Panel PBA does not operate normally .....	97
6-9) When refrigerator ROOM Lamp does not light up .....	98
6-10) If ICE Water is not supplied (OPTION).....	99
6-11) LED blinking frequency depending on protecting functions .....	100
<b>7. PCB DIAGRAM .....</b>	<b>101</b>
7-1) PCB Layout with part position.....	101
7-2) Connector Layout with part position .....	102
<b>8. Wiring Diagram .....</b>	<b>103</b>
<b>9. Block Diagram.....</b>	<b>104</b>
9-1) Whole block diagram .....	104
<b>10. Reference Information .....</b>	<b>105</b>
10-1) Nomenclature .....	105
10-2) Trouble Shooting.....	106
10-3) Q&A .....	108

## 1. PRODUCT INFORMATION

- **Unplug the appliance before carrying out any repair.**
- **Use rated electronic Control equipment.**
  - Make sure to check out Model name, Rated voltage, Rated current, Operation Temp, etc.
- **Upon repair, make sure that all harnesses are watertight and are secured.**
- **Upon repair, completely remove any dust or other foreign substances from housing, harness, connector, etc.**
  - Cleaning will prevent possible risk of fire or malfunction.
- **Check if water or moisture as penetrated into the electronic Control system.**
  - If there is any water or moisture present, take necessary measures such as replacing components, insulation, seals, etc.
- **After repair, . Ensure the product is fully reassembled.**
  - It should be returned to the previous state, with all parts and covers correctly secured in position.
- **Check out the surrounding conditions.**
  - Advise customer to change the location, if the fridge is located in humid, wet place or the installed location is unstable.
- **In to prevent electric shock the appliance must be properly earthed / grounded.**
- **Advise users not to overload socket outlet.**
- **Ensure it is not broken, squashed, cut and there is no evidence of heat damage, Repair or replace the defective power cord immediately.**
- **Users must not attempt to repair the product by themsel.**
- **Do not store other materials except the foods.**
  - Pharmaceutical, Chemical substances: as these require controlled storage environment.
  - Flammable material (alcohol, benzene, ether, LPG, etc) : as there is a risk of explosion.

## PRODUCT INFORMATION

Read all instructions before repairing the product and follow the instructions in order to prevent danger or property damage.  
 Plug out and remove all the items in refrigerator prior to repair.

### CAUTION/WARNING SYMBOLS DISPLAYED

 <p><b>Warning</b></p> <p>Indicates that a danger of death or serious injury exists.</p>	 <p>means "Prohibited".</p>
 <p><b>Caution</b></p> <p>Indicates that a risk of personal injury or material damage exists.</p>	 <p>means "Do not disassemble".</p>
	 <p>means "No contact".</p>
	 <p>means "Warning or Caution".</p>
	 <p>means "Unplug the unit before performing service".</p>
	 <p>means "Earth or Ground".</p>

## Warning & Caution

Plug out to exchange the interior lamp.

- It may cause electric shock.

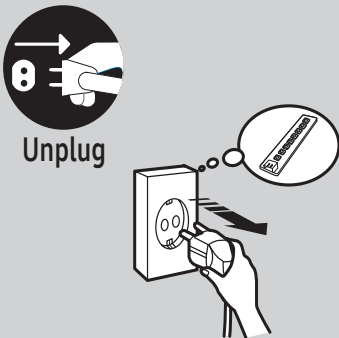

Use the rated components on the replacement.

- Check the correct model, rated voltage, rated current, operating temperature and so on.

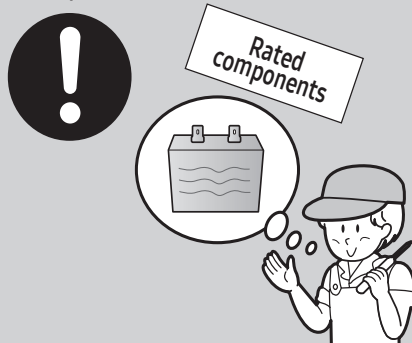

On repair, make sure that the wires such as harness are bundled tightly.

- Bundle tightly wires in order not to be detached by the external force and then not to be wetted.



On repair, remove completely dust or other things of housing parts, harness parts, and check parts.

- Cleaning may prevent the possible fire by tracking or short.



After repair, check the assembled state of components.

- It must be in the same assembled state when compared with the state before disassembly.



Check if there is any trace indicating the permeation of water.

- If there is that kind of trace, change the related components or do the necessary treatment such as taping using the insulating tape.

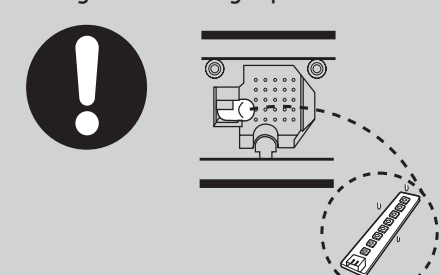

## PRODUCT INFORMATION

※ Please let users know following warnings & cautions in detail.



# Warning & Caution

**Do not allow users to put bottles or kinds of glass in the freezer.**

- Freezing of the contents may inflict a wound.

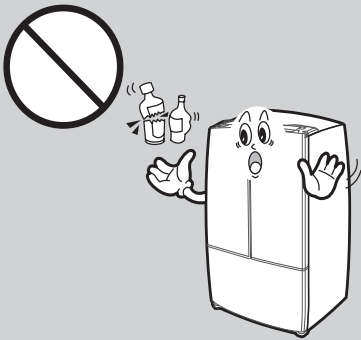

**Do not allow users to store narrow and lengthy bottles or foods in a small multi-purpose room.**

- It may hurt you when refrigerator door is opened and closed resulting in falling stuff down.



**Do not allow users to store pharmaceutical products, scientific materials, etc., in the refrigerator.**

- The products which need precise temperature control should not be stored in the refrigerator.



**Do not allow users to plug several appliances into the same power receptacle.**

- May cause abnormal generation of heat or fire.



Prohibited

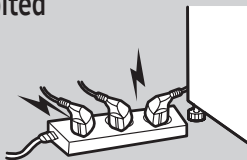

**Do not allow users to disassemble, repair or alter.**

- It may cause fire or abnormal operation which leads to injury.



Do not disassemble

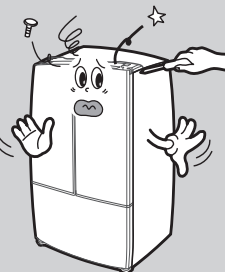

**Do not allow users to bend the power cord with excessive force or do not have the power cord pressed by heavy article.**

- May cause fire.

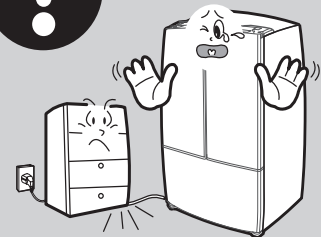

**Do not allow users to store articles on the product.**

- Opening or closing the door may cause things to fall down, which may cause injury.



Prohibition

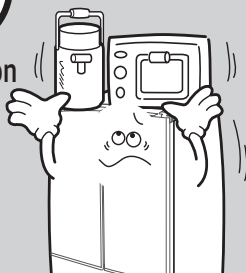

**Do not allow users to install the refrigerator in the wet place or the place where water splashes.**

- Deterioration of insulation of electric parts may cause electric shock or fire.

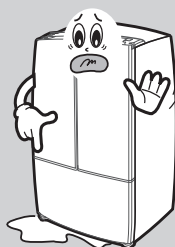

**Make sure of the earth.**

- Be sure the product is properly grounded.



Earth

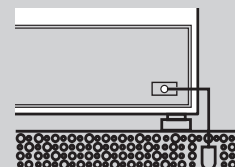

## PRODUCT INFORMATION

### FLOORING

For proper installation, this refrigerator must be placed on a level surface of hard material that is the same height as the rest of the flooring. This surface should be strong enough to support a fully loaded refrigerator, or approximately 660lbs(299kg).

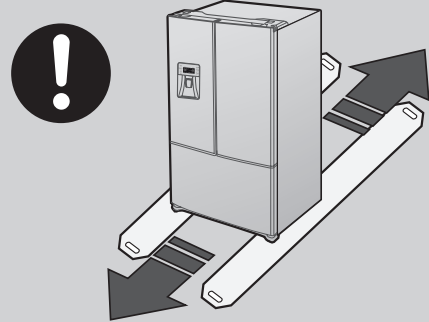

### MOVING

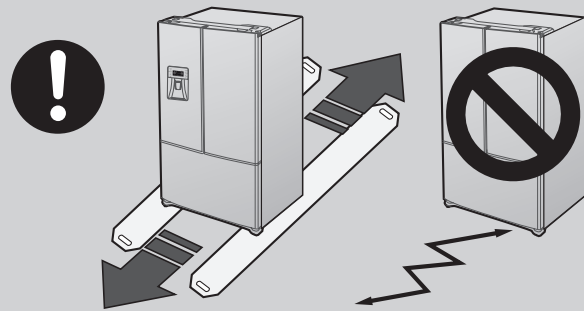

Protect the finish of the flooring. Cut a large section of the cardboard carton and place under the refrigerator where you are working. When moving, be sure to pull the unit straight out and push back in straight.





## 2. PRODUCT SPECIFICATIONS

### 2-1) Introduction of Main Function

■ A newly developed SAMSUNG French door refrigerator in 2020 has the following characteristics.

Image	Feature
	<p><b>Surround Multi Flow</b></p> <ul style="list-style-type: none"> <li>Uniform cooling for each shelf and even in corner in fresh food compartment by center positioned fan and duct with multiple flow effluences.</li> </ul>
	<p><b>Twin Cooling Plus</b></p> <ul style="list-style-type: none"> <li>The refrigerator and the freezer have two evaporators. Given this independent system, the freezer and the refrigerator are cooled individually as required and are, therefore, more efficient. Food odor from the refrigerator does not affect food in the freezer due to separate air flow circulation.</li> </ul>

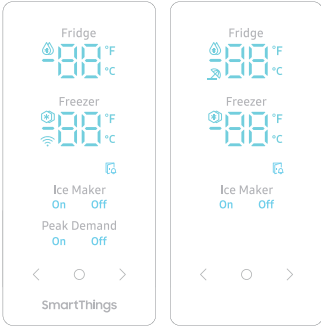
### ► Changing Items

Image	Feature
 	<p><b>Internal Display</b></p> <ul style="list-style-type: none"> <li>The display change more wider and apply Blue LED lighting. And Touch Sensor Lighting make the refrigerator graceful.</li> </ul>
	<p><b>Enhance usability with bigger veggie box</b></p> <ul style="list-style-type: none"> <li>Two big crispers help you store lots of fruits and vegetables or a big cabbage and watermelon.</li> </ul>

# PRODUCT SPECIFICATIONS

## 2-2) Interior Views

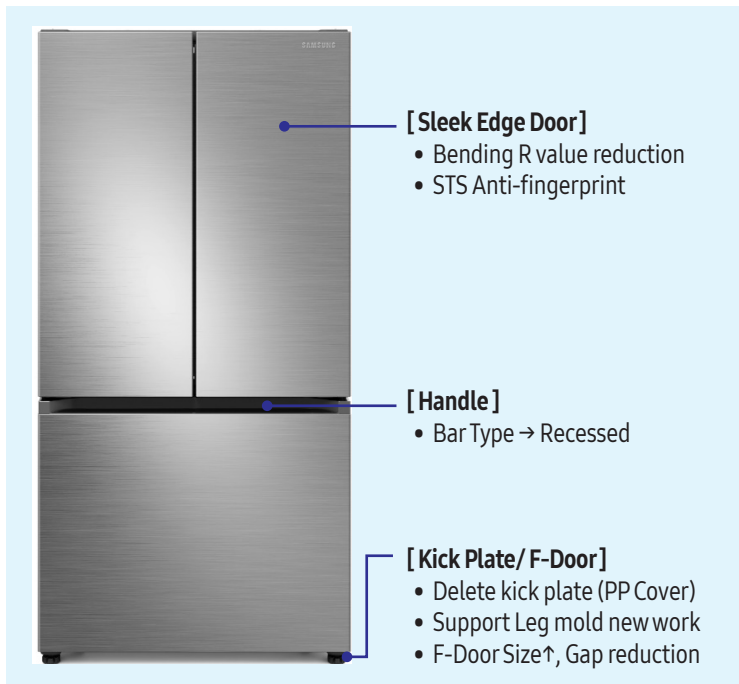

**[ Top Table Display delete ]**

- Add WiFi (N.America / UAE / Kuwait)
- Add temperature and humidity sensor



**[ Improvement of Lighting in fridge room ]**

- Extrusion of LED Cover → SBS Type Structure (Standardization)

**[ Improvement of Duct in Fridge Room ]**

- Duct top extrusion → Flat structure (FDR Duct standardization)

**[ Fridge-Room ADA Display ]**

- Top Table → R-Liner side ADA display applied

**[ Changing the Guard / Panel ]**

- Opaque PP → GPPS transparent
- Guard quantity change (8 → 6 pcs)
- Depth increase (upper/middle, 15mm ↑)
- Panel V / F new production

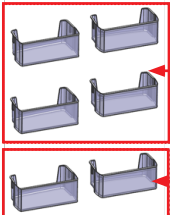

GUARD-REF UP (W303\*D117\*H80)

GUARD-REF LOW (W303\*D179\*H100)

**[ Change of fridge shelf / liner ]**

- Injection Trim assembly type → Front / Back Trim structure
- R room foam plug new production
- Deleting Deli-Bin on the upper shelf

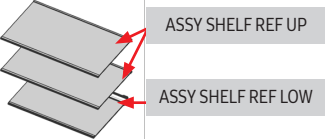

ASSY SHELF REF UP

ASSY SHELF REF LOW

**[ Auto Ice Maker ]**

- Delete (RF57A5032\*, RF57A5232\*)





**[ F-Drawer ] 3pcs → 1pcs**

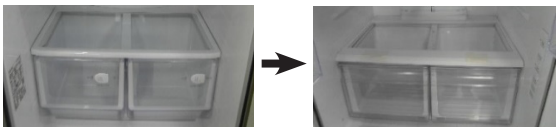

**[ Change of R-drawer ]**

- Box FDR / SBS Type Standardization structure
- Humidity Control Lever → Delete



# PRODUCT SPECIFICATIONS

## 2-3) Model Specification & Specification Chart

ITEM		RF18A5101*	RF44A5002* RF50A5002*	RF50A5202* RF5GA5202*	
		Basic+Wifi	Basic	Disp.	
External size	W	32 1/8"	817mm	817mm	
	D	W/O Door	24 1/2"	625mm	625mm
		W/O Handle	28 1/8"	715mm	715mm
		With Handle	28 1/8"	715mm	715mm
H	With Hinge Cap	70"	1776mm	1776mm	
Net Capacity	Total (AHAM/ISO)		17.5 cu.ft	431L	422L
	Freezer		5.8 cu.ft	100L	100L
	Refrigerator		11.7 cu.ft	331L	322L
Weight	Set		220 lb (100)	100kg	101kg
	Packing		220 lb (100)	107kg	108kg
Packing	Width		34 5/8"	880mm	880mm
	Depth		30 1/2"	776mm	776mm
	Height		75"	1906mm	1906mm
Compressor		NN34M9112ARTT3	NN34H9112APTT3		
Rated Voltage and Frequency		115V/60Hz	230V/50Hz 220~240V/50Hz	220~240V/50Hz	
Cooling Features	Cooling		Twin Cooling Plus		
	No Frost		●		
	Refrigerant		R-600a		
	Energy		E-Star	ISO-F/2.5star	ISO-F/2.5star
Exterior Feature	Display		ADA	ADA	ADA
	Handle		Recessed	Recessed	Recessed
	Water Dispenser		-	-	Yes
	Fingerprint resistant		Yes	Yes	Yes
Interior Feature	Freezer	Interior LED Light	Yes	Yes	Yes
		Power Freeze Function	Yes	Yes	Yes
		Ice Tray	Yes	Yes	Yes
		Number of Drawer	2	2	2
		Auto Ice maker	● (Internal)	● (Internal)	● (Internal)

# PRODUCT SPECIFICATIONS

ITEM		RF18A5101*	RF44A5002* RF50A5002*	RF50A5202* RF5GA5202*	
		Basic+Wifi	Basic	Disp.	
Interior Feature	Fridge	Shelf-Ref	2EA(GLASS)	2EA(GLASS)	2EA(GLASS)
		Cover Veg	1EA(GLASS)	1EA(GLASS)	1EA(GLASS)
		Veg Box	2EA	2EA	2EA
		Water Tank	-	-	Yes
		Number of Door Bin	4	4	4
		Gallon Door Bin	2	2	2
		Lighting	Top LED	Top LED	Top LED
		Power Cool Function	Yes	Yes	Yes
ETC	Door Alarm		Yes	Yes	Yes
	WiFi Embedded		Yes	-	-
	Digital Inverter (10y's warranty)		Yes	Yes	Yes
	Noise level dB(A)		40dBA	40dBA	40dBA
	Sabbath Mode		Yes	-	-

# PRODUCT SPECIFICATIONS

## Model Specification & Specification Chart

ITEM		RF20A5102*	RF49A5002*	RF49A5102*	RF49A5202*	
		Basic+Wifi	Basic	Basic+Wifi	Disp.	
External size	W	321/8"	817mm	817mm	817mm	
	D	W/O Door	261/2"	675mm	675mm	675mm
		W/O Handle	301/8"	765mm	765mm	765mm
		With Handle	301/8"	765mm	765mm	765mm
	H	With Hinge Cap	70"	1776mm	1776mm	1776mm
Net Capacity	Total (AHAM/ISO)		19.5 cu.ft	479L	479L	470L
	Freezer		6.6 cu.ft	116L	116L	116L
	Refrigerator		12.9 cu.ft	363L	363L	354L
Weight	Set		243 lb (106)	106kg	106kg	107kg
	Packing		267 lb (114)	114kg	114kg	115kg
Packing	Width		34 5/8"	880mm	880mm	880mm
	Depth		321/2"	826mm	826mm	826mm
	Height		75"	1906mm	1906mm	1906mm
Compressor		NN34M9112ARTT3	NN34H9112APTT3			
Rated Voltage and Frequency		115V/60Hz	220V/50Hz 230V/50Hz	115V/60Hz	110V/60Hz 127V/60Hz 220~240V/ 50~60Hz	
Cooling Features	Cooling		Twin Cooling Plus			
	No Frost		●			
	Refrigerant		R-600a			
	Energy		E-Star	ISO-F/2.5star	ISO-F/2.5star	ISO-F/2.5star
Exterior Feature	Display		ADA	ADA	ADA	ADA
	Handle		Recessed	Recessed	Recessed	Recessed
	Water Dispenser		-	-	-	Yes
	Fingerprint resistant		Yes	Yes	Yes	Yes
Interior Feature	Freezer	Interior LED Light	Yes	Yes	Yes	Yes
		Power Freeze Function	Yes	Yes	Yes	Yes
		Ice Tray	Yes	Yes	Yes	Yes
		Number of Drawer	2	2	2	2
		Auto Ice maker	● (Internal)	● (Internal)	● (Internal)	● (Internal)

## PRODUCT SPECIFICATIONS

ITEM			RF20A5102*	RF49A5002*	RF49A5102*	RF49A5202*
			Basic+Wifi	Basic	Basic+Wifi	Disp.
Interior Feature	Fridge	Shelf-Ref	2EA(GLASS)	2EA(GLASS)	2EA(GLASS)	2EA(GLASS)
		Cover Veg	1EA(GLASS)	1EA(GLASS)	1EA(GLASS)	1EA(GLASS)
		Veg Box	2EA	2EA	2EA	2EA
		Water Tank	-	-	-	Yes
		Number of Door Bin	4	4	4	4
		Gallon Door Bin	2	2	2	2
		Lighting	Top LED	Top LED	Top LED	Top LED
		Power Cool Function	Yes	Yes	Yes	Yes
ETC	Door Alarm		Yes	Yes	Yes	Yes
	WiFi Embedded		Yes	-	Yes	-
	Digital Inverter (10y's warranty)		Yes	Yes	Yes	Yes
	Noise level dB(A)		40dBA	40dBA	40dBA	40dBA
	Sabbath Mode		Yes	Yes	-	-

# PRODUCT SPECIFICATIONS

ITEM		RF57A5032*	RF57A5232*	RF57B5132*	
		Basic	Disp.	Disp.	
External size	W	817mm	817mm	817mm	
	D	W/O Door	675mm	675mm	675mm
		W/O Handle	765mm	765mm	765mm
		With Handle	765mm	765mm	765mm
	H	With Hinge Cap	1776mm	1776mm	1776mm
Net Capacity	Total (AHAM/ISO)		479L	470L	470L
	Freezer		116L	116L	116L
	Refrigerator		363L	354L	354L
Weight	Set		98kg	98kg	98kg
	Packing		106kg	106kg	106kg
Packing	Width		880mm	880mm	880mm
	Depth		826mm	826mm	826mm
	Height		1906mm	1906mm	1906mm
Compressor		NN34H9112APTT3			
Rated Voltage and Frequency		220V/50Hz	220V/50Hz	220V/50Hz	
Cooling Features	Cooling		Twin Cooling Plus		
	No Frost		●		
	Refrigerant		R-600a		
	Energy		ISO-F/2.5star	ISO-F/2.5star	ISO-F/2.5star
Exterior Feature	Display		ADA	ADA	ADA
	Handle		Recessed	Recessed	Recessed
	Water Dispenser		-	Yes	Yes
	Fingerprint resistant		Yes	Yes	Yes
Interior Feature	Freezer	Interior LED Light	Yes	Yes	Yes
		Power Freeze Function	Yes	Yes	Yes
		Ice Tray	Yes	Yes	Yes
		Number of Drawer	2	2	
		Auto Ice maker	X (Twist IceMaker)	X (Twist IceMaker)	X (Twist IceMaker)

## PRODUCT SPECIFICATIONS

ITEM			RF57A5032*	RF57A5232*	RF57B5132*
			Basic	Disp.	Disp.
Interior Feature	Fridge	Shelf-Ref	2EA(GLASS)	2EA(GLASS)	2EA(GLASS)
		Cover Veg	1EA(GLASS)	1EA(GLASS)	1EA(GLASS)
		Veg Box	2EA	2EA	2EA
		Water Tank	-	-	-
		Number of Door Bin	4	4	4
		Gallon Door Bin	2	2	2
		Lighting	Top LED	Top LED	Top LED
		Power Cool Function	Yes	Yes	Yes
ETC	Door Alarm		Yes	Yes	Yes
	WiFi Embedded		-	-	-
	Digital Inverter (10y's warranty)		Yes	Yes	Yes
	Noise level dB(A)		40dBA	40dBA	40dBA
	Sabbath Mode		Yes	Yes	Yes

# PRODUCT SPECIFICATIONS

## Model Specification & Specification Chart

Items			Specification			
Model			RF18*	RF44* RF50*	RF5G* RF20*	RF49* RF57*
Components for Freezer	Compressor	Model	NN34M9112ARTT3	NN34H9112APTT3	NN34M9112ARTT3	NN34H9112APTT3
		Starting type	BLDC			
		Oil Charge	Mineral 5 250cc			
	Evaporator	Freezer	Split Fin Type			
		Refrigerator	Split Fin Type			
	Condenser		Forced and Natural Convection Type			
	Dryer		Molecular sieve, XH-9 or XH-7HP, 9g			
	Capillary tube (Dia x Length)		F : 0.0323" x 157.5" (0.82mm x 4000mm)			
Refrigerant		R-600a				
Room Temperature Sensor Components	Freezer	Model	Temperature Selection		ON(°F)	OFF(°F)
		THERMISTOR (F-SENSOR) 502AT	-8°F(-22°C)		-5°F(-20°C)	-11°F(-24°C)
			-2°F(-19°C)		1°F(-17°C)	-5°F(-21°C)
	Refrigerator	8°F(-14°C)		11°F(-12°C)	5°F(-15°C)	
		Model	Temperature Selection		ON(°F)	OFF(°F)
		THERMISTOR (R-SENSOR) 502AT	34°F(1°C)		36°F(2°C)	32°F(0°C)
38°F(3°C)			40°F(4°C)	36°F(2°C)		
46°F(7°C)		48°F(8°C)	44°F(6°C)			
Defrost Related Components	Defrost Cycle	First Defrost Cycle (Concurrent defrost of F and R)		6hr ±10min		
		Defrost Cycle (FRE)		12~48hr(vary according to the conditions used)		
		Defrost Cycle (REF)		6~24hr(vary according to the conditions used)		
		Pause time		10 ±1min		
	Defrost Sensor	F/R Defrost - Sensor	Model	THERMISTOR(DKST 1329)		
			SPEC	5.0 kΩ at 77°F(25°C)		
FRE/REF Bimetal		Rated	AC 125V, 6 or 10A(AC 250V, 3 or 5A)			
		Operating temperature	OFF : 140°F(60°C) / ON : 104°F(40°C)			
FRE/REF Thermal Fuse	Rated	AC 250V, 10A				
	Operating temperature	OFF : 228.2~230°F(109~110 °C)				
Electric Components	Defrost Heater (FRE)	Heated at F Defrost		AC 120V, 230W / AC 230V, 230W		
	Defrost Heater (REF)	Heated at R Defrost		AC 115V, 100W / AC 230V, 100W		
	Dispenser Heater	Heated at Case Dispenser (Parallel with French Heater)		AC 120V, 2W / AC 230V, 2W		
	French Heater	Heated at French		AC 120V, 10W / AC 230V, 10W		
	Water Pipe Heater	Heated at Water Pipe		DC 12V, 2W		
	Water Tank Heater	-		-		
	Ice Maker Heater	-		-		
	Ice Room Heater	-		-		
	Protector of FRE/REF Defrost Heater	Bimetal		AC 125V, 6 or 10A(AC 250V, 3 or 5A) OFF : 140°F(60°C). ON : 104°F(40°C)		
		Thermal Fuse		AC 250V, 10A, OFF : 228.2~230°F(109~110 °C)		
	Motor BLDC (FRE)				DC 12V, BLDC(Box Fan, 92mm), 1.2W	
	Motor BLDC (REF)				DC 12V, BLDC(Box Fan, 92mm), 1.2W	
	Motor BLDC (CIRCUIT)				DC 12V, BLDC(C160N, Ø160), 1.32W	
	Geared Motor (ICE MAKER)				-	
	Damper Motor				-	
	LED Lamp	FRE Room (placed REF-L Door Low)		DC 12V, 45~75mA		
REF Room		DC 12V, 288~352mA				
Switch	FRE Door		Max DC 200V 0.5A / MDCG-4 (1EA)			
	REF Door		Max DC 200V 0.5A / MDCG-4 (2EA)			
Power Cord		AC 125V, 7~10A / AC 250V, 7~16A				
Earth Screw		BSBN (BRASS SCREW)				

# PRODUCT SPECIFICATIONS

Items		Specification	
Model		RF57A5032* RF57A5232* RF57B5132*	
Electric Components	Defrost Heater (FRE)	Heated at F Defrost AC 120V, 230W / AC 230V, 230W	
	Defrost Heater (REF)	Heated at R Defrost AC 115V, 100W / AC 230V, 100W	
	Dispenser Heater	Heated at Case Dispenser (Parallel with French Heater) AC 120V, 2W / AC 230V, 2W	
	French Heater	Heated at French AC 120V, 10W / AC 230V, 10W	
	Water Pipe Heater	Heated at Water Pipe -	
	Water Tank Heater	-	
	Ice Maker Heater	-	
	Ice Room Heater	-	
	Protector of FRE/REF Defrost Heater	Bimetal	AC 125V, 6 or 10A (AC 250V, 3 or 5A) OFF : 140°F (60°C). ON : 104°F (40°C)
		Thermal Fuse	AC 250V, 10A, OFF : 228.2~230°C (109~110 °C)
	Motor BLDC (FRE)		DC12V, BLDC (Box Fan, 92mm), 1.2W
Motor BLDC (REF)		DC12V, BLDC (Box Fan, 92mm), 1.2W	
Motor BLDC (CIRCUIT)		DC12V, BLDC (C160N, Ø160), 1.32W	

# PRODUCT SPECIFICATIONS

## 2-4) Dimensions of Refrigerator (Inches)

- Model : RF18A5\* , RF44A5\* , RF50A5 , RF5GA50\* , RF20A5\* , RF49A5\* , RF57A5\* , RF57B5\*

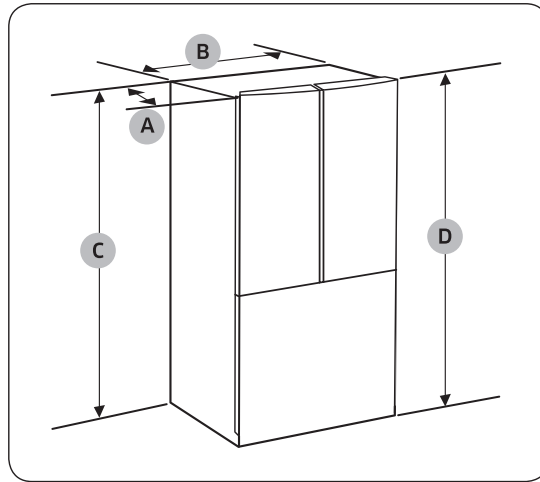

Model	RF18* RF44* RF50* RF5G*	RF20* RF49* RF57*
Depth "A"	715 mm	765 mm
Width "B"	817 mm	817 mm
Height "C"	1749 mm	1749 mm
Overall Height "D"	1776 mm	1776 mm

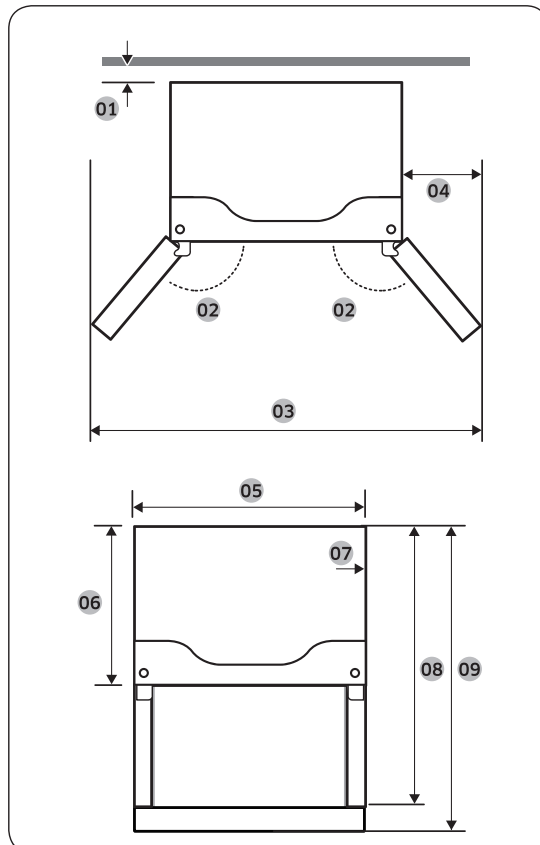

Model	RF18* RF44* RF50* RF5G*	RF20* RF49* RF57*
01	50 mm	50 mm
02	135 °	135 °
03	1393 mm	1393 mm
04	291 mm	291 mm
05	811 mm	811 mm
06	625 mm	675 mm
07	31.5 mm	31.5 mm
08	1056 mm	1101 mm
09	1082 mm	1132 mm

**NOTE**

The measurements in the table above may differ slightly from the actual measurements, depending on the measuring and rounding method.

## PRODUCT SPECIFICATIONS

### 2-5) Optional Material Specification

Photograph	Part Name	Part Code	AMOUNT
	ASSY INSTALL-ACCESSORY	DA99-03490W	1

## PRODUCT SPECIFICATIONS

### 2-6) Refrigerant Route in Refrigeration cycle

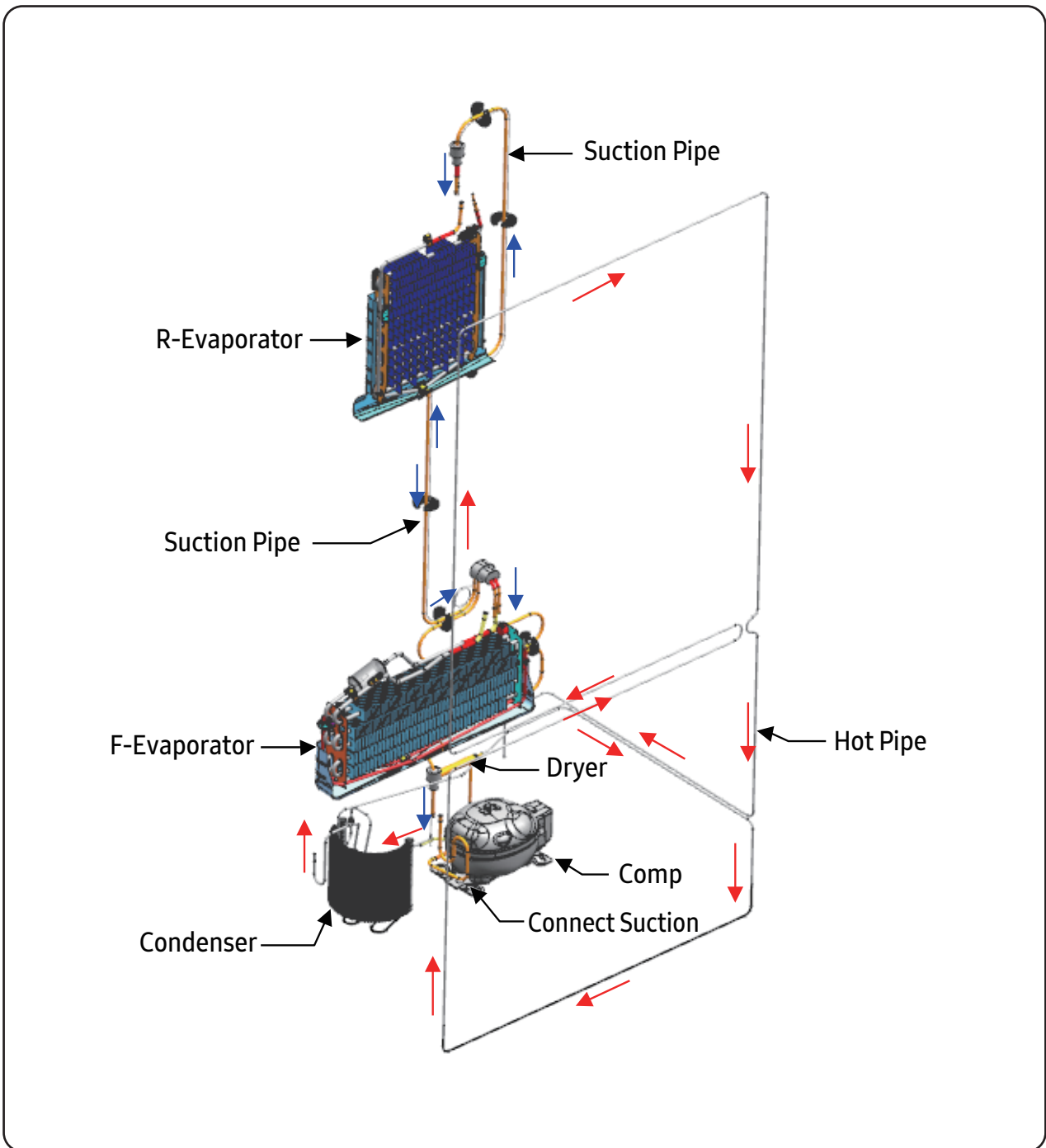

Compressor → Condenser → Hot Pipe → Dryer → R Capillary → R Evaporator  
→ F Evaporator → Suction Pipe → Connect Suction Pipe → Compressor

# PRODUCT SPECIFICATIONS

## 2-7) Principle Of Freezer

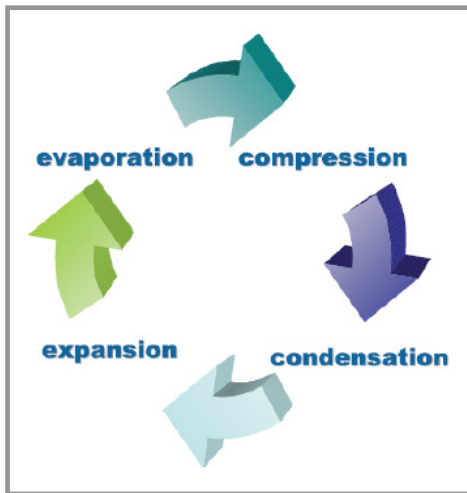

Ref-EVAP  
Pressure: 0 psi  
Temp: -18°F

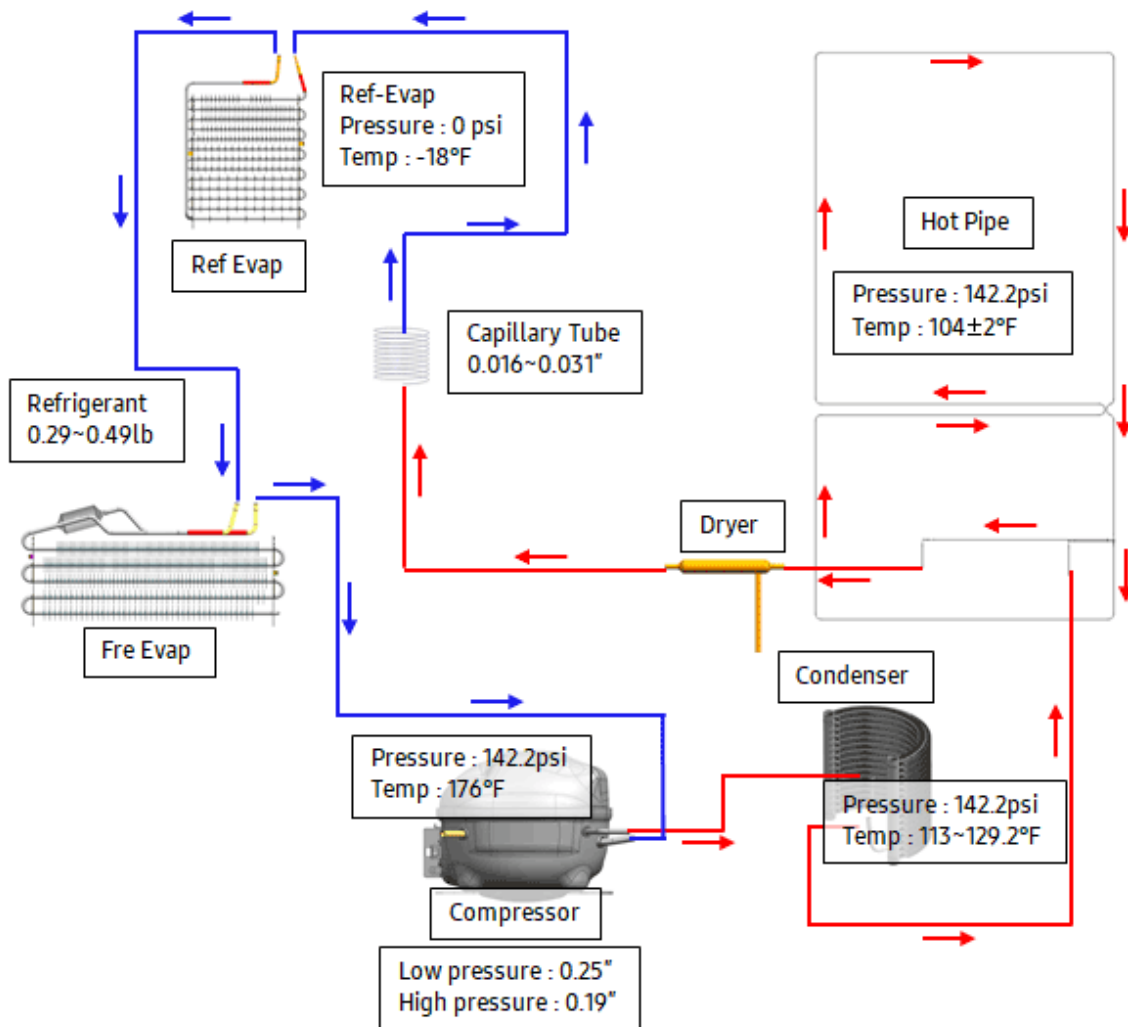

# PRODUCT SPECIFICATIONS

## 2-8) Operation theory of refrigeration cycle components

### ■ Condenser

1) Role : A device which radiates heat to the outside (water/air) to make liquid state for the high temperature / high pressure gas refrigerant discharged from compressor

2) Types

A. **Air-cooling Type** : Condense air by circulating naturally or manually.

1) Natural Convection Type : Used for the household refrigerator which has small condensing capacity.

2) Manual Convection Type : Circulate air manually by FAN-Motor (Large capacity)

B. **Water-cooling Type** : Make cooling water pass through the pipe in the condenser (Large capacity)

#### ※ Location

① CLUSTER heat-radiating type : All Pipes **effective for radiating heat** are formed in the right/left, and front side of refrigerator with hard urethanes and radiate heat through the whole surfaces of cabinet to ambient air.

② Install the condenser on the outside of the product. (An old model)

③ Make them cluster at the lower part of product and radiate heat manually by fan.

• **Radiate condensed potential heat up to liquefy completely and make change the state without changing the gas temperature itself.**

#### ※ Pipe thickness

① Micro-channel tube : 0.01"(0.25mm) ② Steel Pipe : 0.02"(0.5mm), 0.028"(0.7mm) ③ Capillary : 0.019"(0.49mm)

#### ※ Condenser length

① CONDENSER : 9.84"(0.25m) × 14Pcs (Parallel) ② HOT-PIPE : 328.5"(8.345m)

### ■ Capillary

1) Role : A device which makes low temperature and pressure refrigerant by reducing the pressure the normal temperature / high pressure liquid refrigerant condensed from condenser, and supply it to the evaporator.

A. To evaporate more lower temperature in case of evaporation.

B. It flows to the evaporator without back flowing to condenser, if compressor stops, and the difference of pressure between high pressure and low pressure is small so it is easy to operate the compressor again.

2) Outline

A. Thickness : 0.019 inch

B. Length : It is changeable to low temperature and pressure (142->71 psi) depends on the 157.5inch of thin and long copper pipe wall resistance.

### ■ Evaporator

1) Role : As the low pressure liquid refrigerant flowed from capillary absorbs heat inside of the refrigerator, it becomes low pressure gas and refrigerate the foods.

2) Theory : The low pressure refrigerant flowed to evaporator operates cooling which takes ambient evaporated potential heat with maintaining the evaporation up to evaporate completely.

3) Types:

A. ROLL-BOND Evaporator → Direct Cooling

☞ Rolled and adhere the 2 aluminum plate and then make refrigerant passage.

B. FIN-PIPE Evaporator → Indirect cooling

☞ A small aluminum plate on the aluminum pipe to increase the cooling effect.

### ■ Compressor

1) Role : It operates same as pump which pull out the subterranean water. It inhales the low temperature and pressure refrigerant gas (flowed out) from evaporator and make high temperature and pressure refrigerant liquid in the compressor and send it to the condenser.

2) Type

A. Back-and-forth motion type : A method that piston makes back-and-forth motion through **shaft and cylinder of motor rotation** and compresses. ※ Used for household refrigerant.

B. Rotary Type : **A method that inhales the refrigerant gas through the gap between the outside of rotor electric attached on the shaft (rotation axis) and the inside of cylinder and compresses.**

C. Centrifugal Type

## PRODUCT SPECIFICATIONS

### ■ Dryer

- 1) Role : Absorb the moisture from the refrigerant that refrigeration cycle circulates and eliminate the foreign substance.
- 2) Structure : If even some moisture is included refrigerant is impossible to circulate by freezing the small capillary outlet, so silica gel or molecular sieve is (included and) sealed to absorb the internal moisture, and install a minute net to eliminate the foreign substance.



#### ※ Influence of moisture

- ① Moisture precipitation – Blocked by ice
- ② Refrigerant and reaction
- ③ Life reduction of oil
- ④ Acceleration of oxidization
- ⑤ Copper plating phenomenon
- ⑥ Gas dissolution by the interaction of synthetic insulating material (insulator)

#### ※ Influence of foreign substance

- ① Increase of condensed temperature.
- ② Increase of temperature.
- ③ Decrease of cooling efficiency
- ④ Shorten the life by friction between oil and foreign substance in the compressor.

### ■ Accumulator

- 1) Role : To send a pure refrigerant gas to compressor by removing completely the refrigerant liquid from evaporator.  
※ If a refrigerant liquid go into the compressor, overload is occurred.

# PRODUCT SPECIFICATIONS

## 2-9) Refrigeration Cycle Type

### ■ HM Cycle

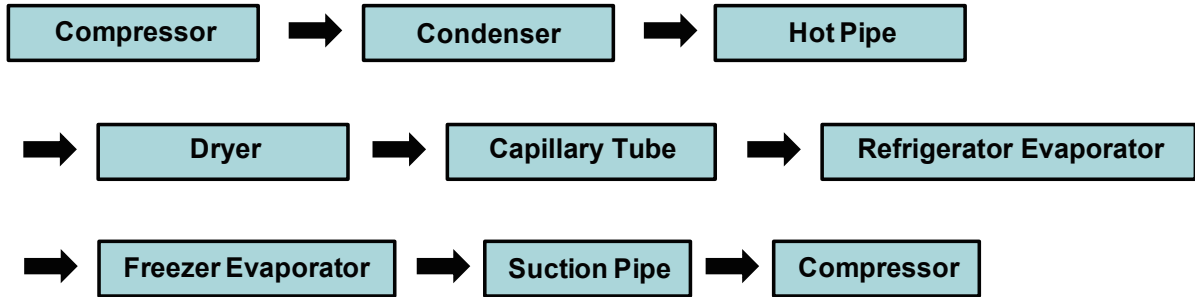

## 2-10) Cooling Air Circulation

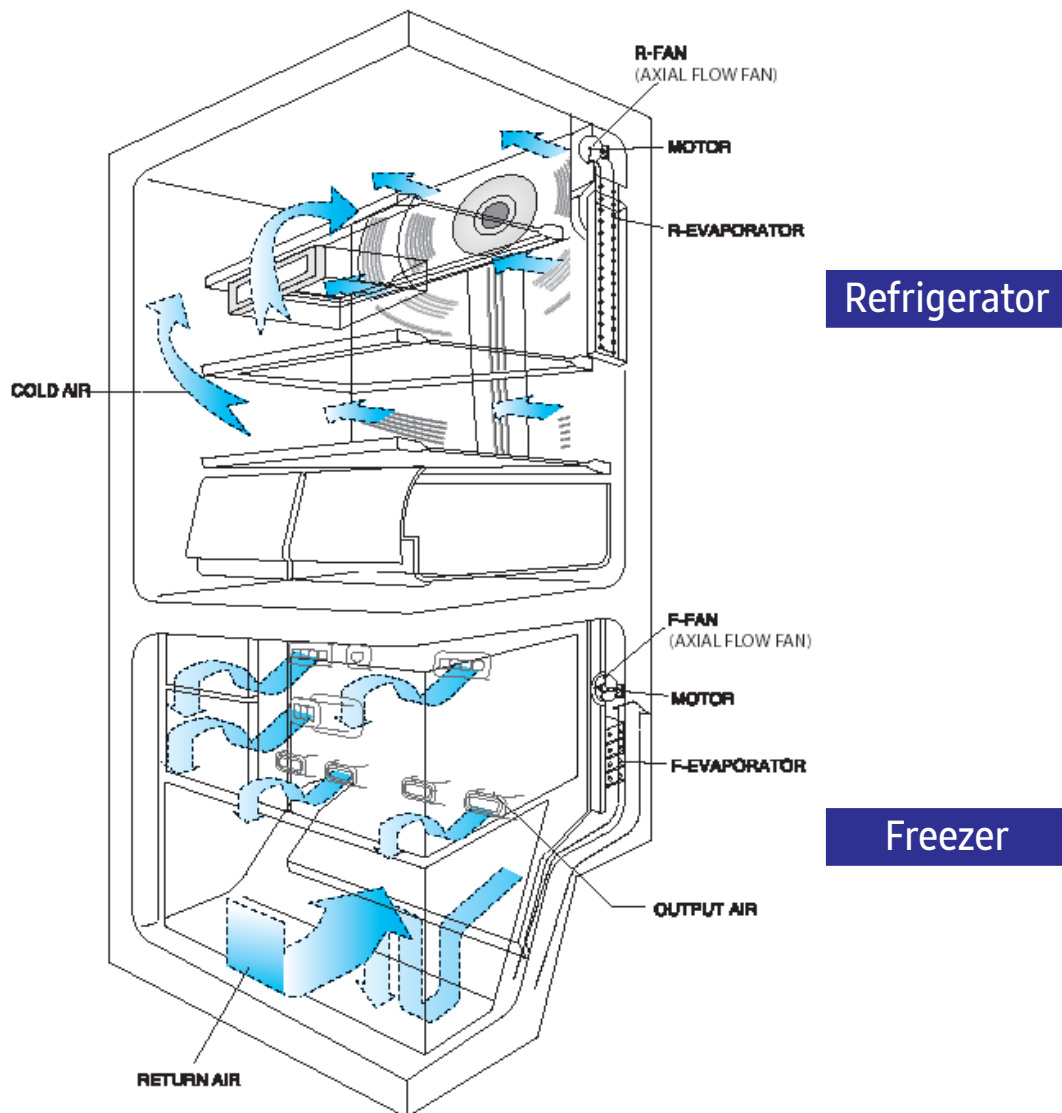

## 3. FUNCTIONS & FEATURES

### 3-1) Control Display

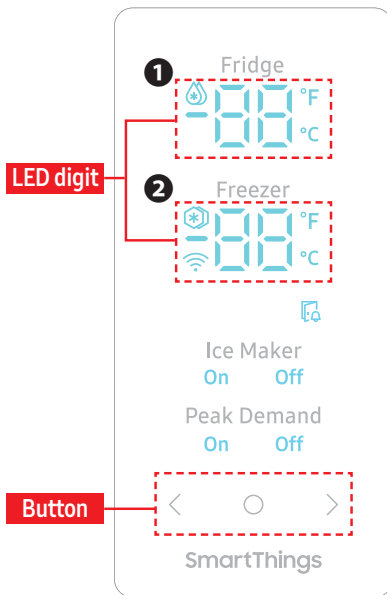

#### ① Setting the desired temperature or function

- Tap any button (<, O, or >) to wake up the display.
  - This step may not apply to some models.
- Tap O to select the fridge, freezer or any other functions.
  - The selected compartment's indicator or function's indicator blinks.
- Tap < or > to select the desired temperature or function configuration.
  - Refer to the table for available selection for each compartment and function.
- Wait for 5 seconds or Tap 'O' to confirm your selection.
  - The selected compartment's indicator or function's indicator stops blinking.
- After confirm your selection, If you tap O again within 5 seconds, you can change the setting again from the previously changed item.
- After confirm your selection, If you tap O after 5 seconds, you can change the function from the first item, Fridge Settings.

#### NOTE

Each time you press a button on the control panel, you will hear a short beep.  
When you do not press any button, all LEDs become turned off for the minimum energy consumption.

<b>Fridge</b>	<ul style="list-style-type: none"> <li>• When the Fridge temperature indicator blinks, press the '&lt;' key to set it as follows                      (Vacation) → 7 °C → 8 °C → 5 °C → 4 °C → 3 °C → 2 °C → 1 °C → (Power Cool)</li> <li>• When the Fridge temperature indicator blinks, press the '&gt;' key to set it as follows                      (Power Cool) → 1 °C → 2 °C → 3 °C → 4 °C → 5 °C → 6 °C → 7 °C → (Vacation)</li> <li>• Power Cool speeds up the cooling process at maximum fan speed. The fridge keeps running at full speed for two and a half hours and then returns to the previous temperature.</li> <li>• Use the Vacation function if you are going on a Vacation or a business trip, or if you do not intend to use the fridge for an extended time. The fridge temperature will be kept under 17 °C, but the freezer remains active as previously set.</li> </ul>
<b>Freezer</b>	<ul style="list-style-type: none"> <li>• When the Freezer temperature indicator blinks, press the '&lt;' key to set it as follows.                      (Fridge) → -15 °C → -16 °C → -17 °C → -18 °C → -19 °C → -20 °C → -21 °C → -22 °C → -23 °C → (Power Freeze)</li> <li>• When the Freezer temperature indicator blinks, press the '&gt;' key to set it as follows.                      (Power Freeze) → -23 °C → -22 °C → -21 °C → -20 °C → -19 °C → -18 °C → -17 °C → -16 °C → -15 °C → (Fridge)</li> <li>• Power Freeze speeds up the freezing process at maximum fan speed. The freezer keeps running at full speed for 50 hours and then returns to the previous temperature. To freeze large amounts of food, activate Power Freeze for at least 20 hours before putting food in the freezer.</li> <li>• If you select (Fridge), the freezer operates as a fridge and the temperature setting changes to 3 °C.</li> <li>• Empty the ice bucket before you select (Fridge).</li> </ul> <p><b>WARNING</b></p> <ul style="list-style-type: none"> <li>- Do not put glass bottle containing liquid in the freezer while it is in the Fridge mode. When you unselect the Fridge mode, and the freezer returns to the freezer mode, the liquid in the glass bottles will freeze, which can cause the glass bottles to break or burst in the freezer.</li> <li>- Make sure to remove frozen foods from the freezer before you select the Fridge mode. Frozen foods will melt and spoil as the temperature increases.</li> <li>- Make sure to remove foods that you do not want to freeze before you unselect the Fridge mode and use the freezer to freeze.</li> </ul> <div style="border: 1px solid black; padding: 5px; margin-top: 10px;"> <p><b>NOTE</b></p> <ul style="list-style-type: none"> <li>- When you use Power Freeze function the energy consumption of the refrigerator will increase. Remember to turn it off when you don't need it and return the freezer to your original temperature setting.</li> <li>- If you are going to use the freezer in the freeze mode, we strongly recommend that you use plastic containers to store food, especially vegetables.</li> </ul> </div>
<b>°F ↔ °C</b>	<ul style="list-style-type: none"> <li>• Available selection : °F ↔ °C</li> <li>• You can switch the temperature scale between Fahrenheit and Celsius. To switch the temperature scale, Tap O until °F / °C indicator blinks. When °F / °C indicator blinks, Tap &lt; to change the current temperature scale to Fahrenheit. When °F / °C indicator blinks, Tap &gt; to change the current temperature scale to Celsius.</li> </ul>
<b>Ice Maker</b>	<ul style="list-style-type: none"> <li>• Available selection: Ice Maker On ↔ Off</li> <li>• You can turn on or off the Ice Maker. To change the settings of the Ice Maker, press O until the On / Off indicator on the Ice Maker blinks. When the On / Off indicator on the Ice Maker blinks, click &lt; to set it to Ice Maker On. When the On / Off indicator on the Ice Maker blinks, click &gt; to set to Ice Maker Off.</li> </ul>

## FUNCTIONS & FEATURES

<b>Peak Demand</b>	<ul style="list-style-type: none"> <li>Available selection: Ice Maker On ↔ Off</li> <li>You can turn on or off Peak Demand.</li> </ul> <p>To change the setting of Peak Demand, press 0 until the On / Off display of Peak Demand blinks. When the On / Off display of Peak Demand blinks, press &lt; to set to Peak Demand On. When the On / Off display of Peak Demand blinks, press &gt; to set to Peak Demand Off.</p>
<b>Door Alarm</b>	<ul style="list-style-type: none"> <li>Normally, this icon is off. But If the door is left open for more than 2 minutes, the alarm will sound with this Door Alarm icon blinking. If the door is left open for 5 minutes, internal light will blink for 5 minutes and turn off.</li> </ul>

### NOTE

Each time you press a button on the control panel, you will hear a short beep.  
When you do not press any button, all LEDs become turned off for the minimum energy consumption.

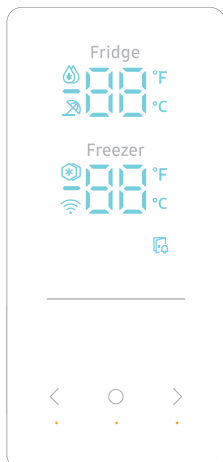
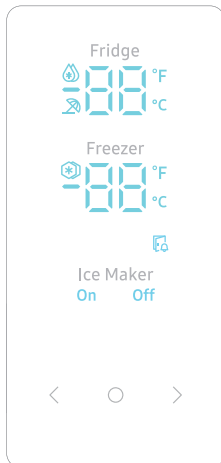
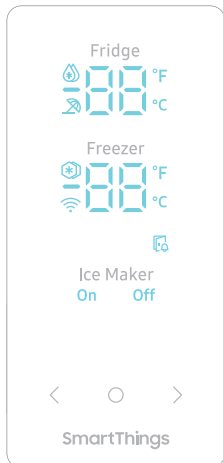
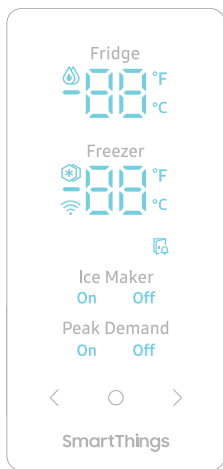

<b>01 Fridge indicator</b>	<ul style="list-style-type: none"> <li>Displays the current or desired temperature of the fridge.</li> <li>🌊 indicates that the Power Cool function is on.</li> <li>🌊 indicates that the Vacation function is on. (Optional)</li> <li>°F indicates that the Fahrenheit temperature scale function is on.</li> <li>°C indicates that the Celsius temperature scale function is on.</li> </ul>
<b>02 Freezer indicator</b>	<ul style="list-style-type: none"> <li>Displays the current or desired temperature of the freezer.</li> <li>❄️ indicates that the Power Freeze function is on.</li> <li>❄️ indicates that the freezer is operating in Fridge mode. (Optional)</li> <li>📶 indicates that the Network is connected. (Optional)</li> <li>°F indicates that the Fahrenheit temperature scale function is on.</li> <li>°C indicates that the Celsius temperature scale function is on.</li> </ul>
<b>03 Door open indicator</b>	This indicator blinks with an alarm if the door is left open for more than 2 minutes.
<b>04 Ice Maker (Optional)</b>	<p>The ice maker has 2 indicators (Ice Maker On / Off) to indicate its operating status.</p> <ul style="list-style-type: none"> <li>When the ice maker operates, the corresponding indicator (Ice Maker On) turns on.</li> <li>When the ice maker is turned off, the corresponding indicator (Ice Maker Off) turns on.</li> </ul> <p>To enable ice making, you must turn the ice maker on.</p>
<b>05 Peak Demand (Optional)</b>	<p>The Peak Demand has 2 indicators (Peak Demand On / Off) to indicate its operating status.</p> <ul style="list-style-type: none"> <li>When the Peak Demand operates, the corresponding indicator (Peak Demand On) turns on.</li> <li>When the Peak Demand is turned off, the corresponding indicator (Peak Demand Off) turns on.</li> </ul> <p>To enable ice making, you must turn the ice maker on.</p>
<b>06 Buttons</b>	<ul style="list-style-type: none"> <li>When the display is off, tap any button to wake up the display.</li> <li>Use 0 to select the fridge or freezer and &lt; or &gt; to select the desired temperature or function for the selected compartment.</li> </ul>

### NOTE





- The control panel is designed to stay off when the refrigerator is not in use. It only becomes active and lights up when you open the door or tap the buttons.
- If the door is left open for 5 minutes, internal light will blink for 5 minutes and turn off. This is to alert hearing-impaired users that a door is open. Note that this function is normal.

## 4. DISASSEMBLY AND REASSEMBLY

### 4-1) Precaution

- **Unplug the refrigerator before cleaning and making repairs.**
- **Do not disassemble or repair the refrigerator by yourself.**  
- It may cause risk of causing a fire, malfunction and/or personal injury.
- **Remove any foreign matter or dust from the power plug pins.**  
- Otherwise there is a risk of fire.
- **Do not use a cord that shows cracks or abrasion damage along its length or at either end.**
- **Do not plug several appliances into the same multiple power board. The refrigerator should always be plugged into its own individual electrical which has a voltage rating that matched the rating plate.**  
- This provides the best performance and also prevents overloading house wiring circuits, which could cause a fire hazard from overheated wires.
- **Do not install the refrigerator in a damp place or place where it may come in contact with water.**  
- Deteriorated insulation of electrical parts may cause an electric shock or fire.
- **The refrigerator must be grounded.**  
- You must ground the refrigerator to prevent any power leakages or electric shocks caused by current leakage from the refrigerator.
- **Do not put bottles or glass containers in the freezer.**  
- When the contents freeze, the glass may break and cause personal injury.
- **Do not store volatile or flammable substances in the refrigerator.**  
- The storage of benzene, thinner, alcohol, ether, LP gas and other such products may cause explosions.

### ■ Required Tools

IMAGE	ITEM	USE
	Phillips Head Driver	Use for assembling and disassembling of screw.
	Flat Head Driver	Use for assembling and disassembling of HomeBar, Dispenser, Delicatessen Box, Main PBA etc...
	Hex Wrench $\varnothing$ 2mm	Use for assembling and disassembling of Handle.
	Socket Wrench $\varnothing$ 10mm	Use for assembling and disassembling of Door Hinge.





### ■ Water whitening phenomenon

All water provided to refrigerators flows through the core filter which is an alkaline water filter. In this process, the pressure in the water that has flowed out of the filter gets increased, and massive oxygen and nitrogen become saturated. When this water flows out in the air, the pressure plummets and the oxygen and nitrogen get supersaturated so that they turn into gas bubbles. The water could look misty due to these oxygen bubbles. It is not because dust or chemicals, just a few seconds later, it will be clean again.

# DISASSEMBLY AND REASSEMBLY

## 4-2) Refrigerator Door (Hinge Up)

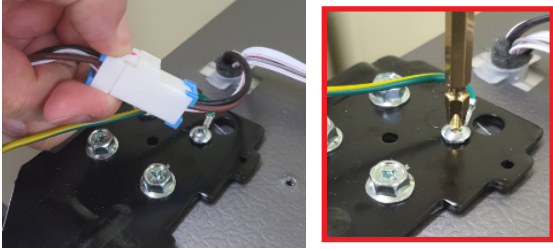
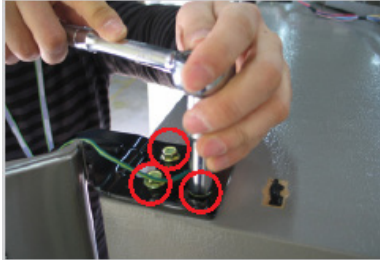



 When disassembling, make sure the unit turned off.

Part Name	How To Do	Descriptive Picture
Refrigerator Door (Hinge Up)	<p><b>[Disassembly]</b> 1. Remove the 3 screws holding down the Top Table and remove it.</p>	
	<p><b>[Disassembly]</b> 2. Disconnect electric wire on the top of the refrigerator.</p>	
	<p><b>[Disassembly]</b> 3. Disconnect electric wire of the door and cabinet. Remove the screw that holds the ground wire with a philips screwdriver(+).</p>	
	<p><b>[Disassembly]</b> 4. Remove the 3 hex bolts that hold the hinge on the top of the refrigerator with the 7/16" socket wrench.</p>	
	<p><b>[Disassembly]</b> 5. Separate the Hinge from the door.</p>	
	<p><b>[Disassembly]</b> 6. Lift the door straight up to remove. Be careful not to drop or scratch the doors while removing the doors.</p>	

## DISASSEMBLY AND REASSEMBLY

### 4-3) Refrigerator Door (Hinge Mid)

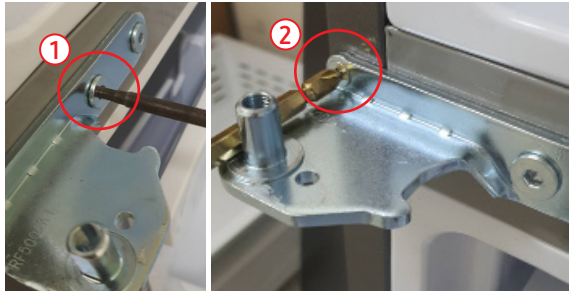
 When disassembling, make sure the unit turned off.



Part Name	How To Do	Descriptive Picture
Refrigerator Door (Hinge Mid)	<p><b>[Disassembly]</b> 7. Separate the cap on the middle hinge.</p>	
	<p><b>[Disassembly]</b> 8. With a Philips head screwdriver, remove the screw ①. With a 3/16"(0.2) in Hex wrench, remove the 2 flat head bolt ②. Remove the mid left and right door hinges.</p>	
	<p><b>[Assembly]</b> 1. Assemble the mid left and right door hinges. With a 3/16"(0.2) in Hex wrench, assemble the 2 flat head bolt ①. With a Philips head screwdriver, assemble the screw ②.  * Make sure to assemble the hinges in the following order to prevent them from being twisted. : BOLT ① → SCREW ②</p>	
	<p><b>[Assembly]</b> 2. Assemble the cap on the middle hinge.</p>	
	<p><b>[Assembly]</b> 3. Assemble the door on mid hinge. Be careful not to drop or scratch the doors while assemble the doors.</p>	

 If you want to assembly, follow the reverse order.

# DISASSEMBLY AND REASSEMBLY

## 4-4) Refrigerator Door (Hinge Up)

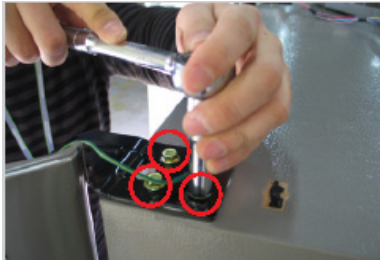
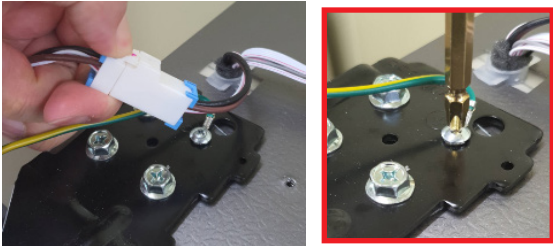
 When disassembling, make sure the unit turned off.





Part Name	How To Do	Descriptive Picture
Refrigerator Door (Hinge Up)	<p>[Assembly] 4. Assemble the hinge up with door.</p>	
	<p>[Assembly] 5. Assemble the 3 hex bolts that hold the hinge on the top of the refrigerator with the 7/16" socket wrench.</p>	
	<p>[Assembly] 6. Connect electric wire of the door &amp; cabinet. Assemble the screw that holds the ground wire with a philips screwdriver(+).</p>	
	<p>[Assembly] 7. Connect electric wires on the top of the refrigerator with "Top Table".</p>	
	<p>[Assembly] 8. Assemble "Top Table" with 3 screws.</p>	

 If you want to assembly, follow the reverse order.

# DISASSEMBLY AND REASSEMBLY

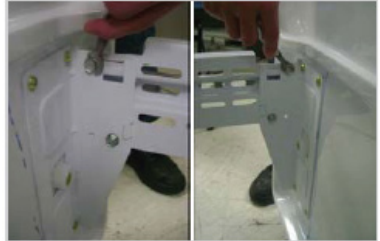
## 4-5) Freezer Door

 When disassembling, make sure the unit turned off.

Part Name	How To Do	Descriptive Picture
Freezer Door	<p><b>[Disassembly]</b> 1. After opening the Freezer door, lift the drawer box.</p>	
	<p><b>[Disassembly]</b> 2. Remove 4 hex head bolts from both sides with a socket wrench(7/16").</p>	
	<p><b>[Disassembly]</b> 3. Lift up the freezer door from the rails. Be careful not to drop and scratch the freezer door.</p>	
	<p><b>[Assembly]</b> 1. Assemble the door on rail. Be careful not to drop and scratch the freezer door.</p>	
	<p><b>[Assembly]</b> 2. Assemble the 4 hex head bolts from both sides with a socket wrench(7/16").</p>	
	<p><b>[Assembly]</b> 3. Assemble the drawer box.</p>	

 If you want to assembly, follow the reverse order.

# DISASSEMBLY AND REASSEMBLY

## 4-6) Gasket

 When disassembling, make sure the unit turned off.

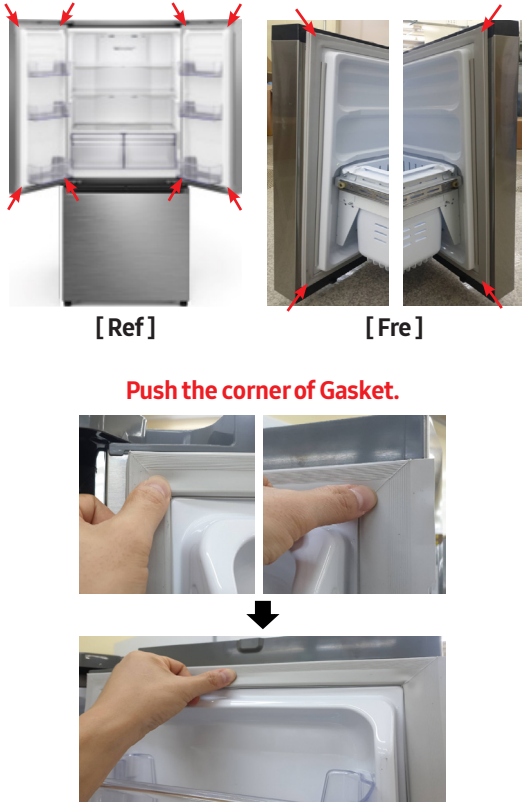





Part Name	How To Do	Descriptive Picture
Gasket	<p><b>[Disassembly]</b></p> <ol style="list-style-type: none"> <li>1. Pull the 4 corners of gasket.</li> <li>2. Pull the center of gasket.</li> </ol>	 <p style="text-align: center;"><b>[Ref]</b>                      <b>[Fre]</b></p> <p style="text-align: center;"><b>Pull the corner of Gasket.</b></p>
	<p><b>[Assembly]</b></p> <ol style="list-style-type: none"> <li>1. Push the 4 corners of gasket.</li> <li>2. Push the center of gasket.</li> </ol>	 <p style="text-align: center;"><b>[Ref]</b>                      <b>[Fre]</b></p> <p style="text-align: center;"><b>Push the corner of Gasket.</b></p>

 If you want to assembly, follow the reverse order.

# DISASSEMBLY AND REASSEMBLY

## 4-7) Freezer Door Switch

 When disassembling, make sure the unit turned off.



Part Name	How To Do	Descriptive Picture
Freezer Door Switch	<p><b>[Disassembly]</b> 1. Remove 1 screw at the lower part of the Freezer.</p>	
	<p><b>[Disassembly]</b> 2. Separate the Cap.</p>	
	<p><b>[Disassembly]</b> 3. Separate the Housing.</p>	
	<p><b>[Assembly]</b> 1. Assemble the Housing.</p>	
	<p><b>[Assembly]</b> 2. Assemble the Cap.</p>	
	<p><b>[Assembly]</b> 3. Assemble 1 screw at the lower part of the Freezer.</p>	

 If you want to assembly, follow the reverse order.

# DISASSEMBLY AND REASSEMBLY

## 4-8) Refrigerator Light

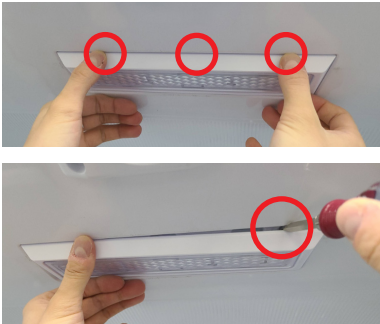
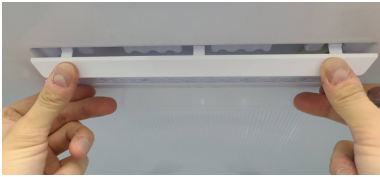
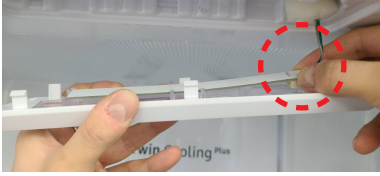
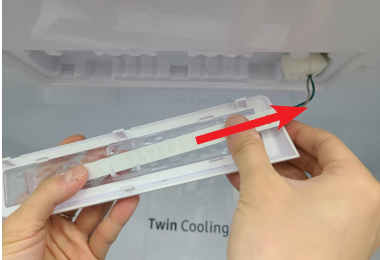

 When disassembling, make sure the unit turned off.

Part Name	How To Do	Descriptive Picture
Refrigerator Light	<p><b>[Disassembly]</b> 1. Insert the small flat-heat screwdriver at inert point's gap between liner and cover lamp. (3 points)</p>	
	<p><b>[Disassembly]</b> 2. Remove the lamp cover by pulling it down as pushing the front of lamp cover.</p>	
	<p><b>[Disassembly]</b> 3. Slightly lift the socket side.</p>	
	<p><b>[Disassembly]</b> 4. Slide out the led lamp from the cover.</p>	
	<p><b>[Disassembly]</b> 5. Push the hook trigger and pull the connector to separate.</p>	
	<p><b>[Assembly]</b> 1. Connect the connector with LED socket pulling the connector.</p>	

 If you want to assembly, follow the reverse order.

## DISASSEMBLY AND REASSEMBLY

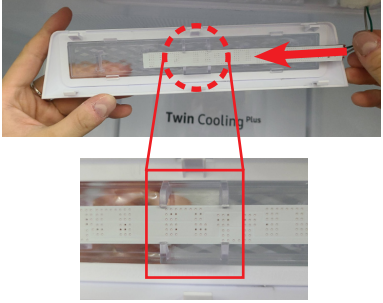
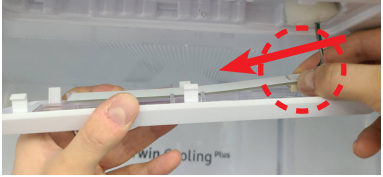
 When disassembling, make sure the unit turned off.

Part Name	How To Do	Descriptive Picture
Refrigerator Light	<p><b>[Assembly]</b> 2. Slide in the led lamp to cover lamp. (LED must be located under the hook feature of cover lamp.)</p>	
	<p><b>[Assembly]</b> 3. When assemble, slightly bend up the led socket side and slide in the led lamp.</p>	
	<p><b>[Assembly]</b> 4. Locate the cover lamp at liner and hook the back side hook first, then hook the front 3 points and push up.</p>	

 If you want to assembly, follow the reverse order.

# DISASSEMBLY AND REASSEMBLY

## 4-9) TOP TABLE (With Sensor Temp)

 When disassembling, make sure the unit turned off.

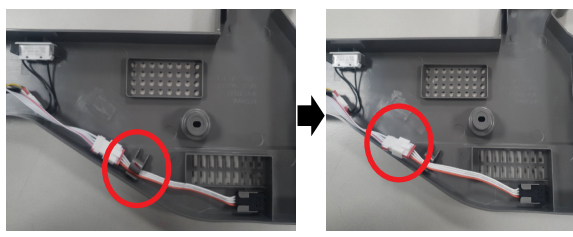
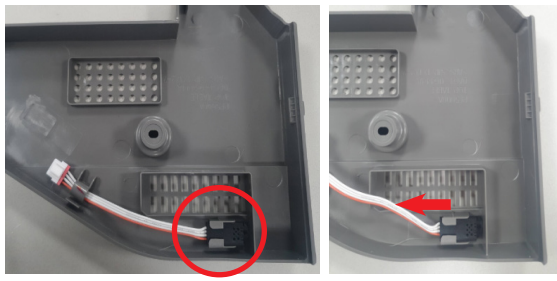
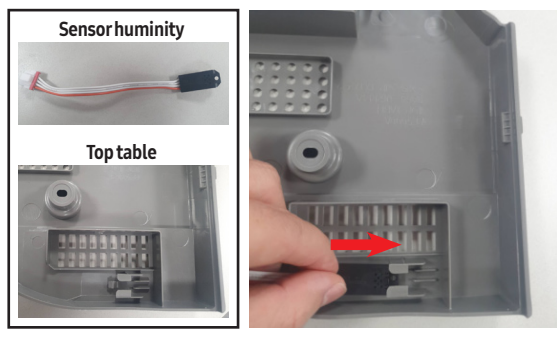
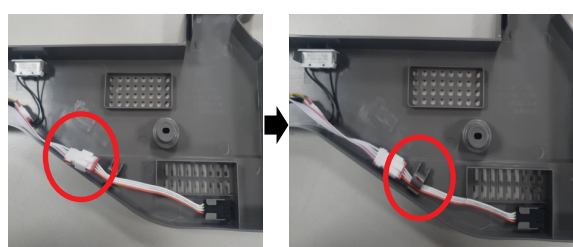

Part Name	How To Do	Descriptive Picture
TOP TABLE	<p><b>[Disassembly]</b> 1. Remove the 3 screws holding down the Top Table and remove it.</p>	
	<p><b>[Disassembly]</b> 2. Separate wire from top table hook and then disconnect wire housing</p>	
	<p><b>[Disassembly]</b> 3. Pull the wire out to separate top table structure.</p>	
	<p><b>[Assembly]</b> 1. Slide in the sensor to top table assembly structure. (Sensor must be located under the hook feature of top table)</p>	
	<p><b>[Assembly]</b> 2. Connect sensor wire with top table sub wire and then fix the wire in top table hook.</p>	

 If you want to assembly, follow the reverse order.

# DISASSEMBLY AND REASSEMBLY

## 4-10) Freezer Light

 When disassembling, make sure the unit turned off.

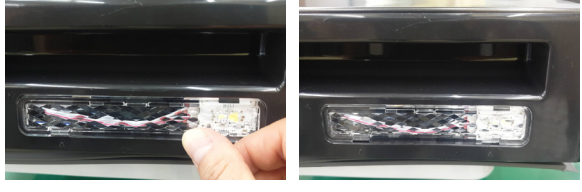
Part Name	How To Do	Descriptive Picture
Freezer Light	<p><b>[Disassembly]</b> 1. Remove the Cover Lamp by a Flat Head Driver.</p>	
	<p><b>[Disassembly]</b> 2. Separate the Led Lamp from the wire.</p>	
	<p><b>[Assembly]</b> 1. Connect the Wire &amp; Led Lamp. Assemble the Led Lamp with Cap Door Low.</p>	
	<p><b>[Assembly]</b> 2. Assemble the Cover Lamp on Cap Door Low.</p>	

 If you want assembly, follow the reverse order.

# DISASSEMBLY AND REASSEMBLY

## 4-11) Glass shelves

 When disassembling, make sure the unit turned off.

Part Name	How To Do	Descriptive Picture
<p><b>Glass shelves</b></p>	<p>1. When pulling out the shelf, if it is not slid out well, lift it up slightly and pull out again.</p>	

 If you want to assembly, follow the reverse order.

## 4-12) Drawer







 When disassembling, make sure the unit turned off.

Part Name	How To Do	Descriptive Picture
<p><b>CASE VEG</b></p>	<p>1. Hold the handle and pull out as much as possible. 2. Then you take it up and disassemble it.</p>	

 If you want to assembly, follow the reverse order.

## DISASSEMBLY AND REASSEMBLY







 When disassembling, make sure the unit turned off.

Part Name	How To Do	Descriptive Picture
TRAY FRE-UP	<p><b>[Disassembly]</b> 1. Open the freezer door as much as possible.</p>	
	<p><b>[Disassembly]</b> 2. Hold the handle and lift it up.</p>	
	<p><b>[Disassembly]</b> 3. and then you take it up and disassemble it.</p>	
	<p><b>[Assembly]</b> 1. Hold the handle and push it in.</p>	
	<p><b>[Assembly]</b> 2. Place it on the TRAY DRAWER.</p>	
	<p><b>[Assembly]</b> 3. Check if it works.</p>	

 If you want to assembly, follow the reverse order.

# DISASSEMBLY AND REASSEMBLY

 When disassembling, make sure the unit turned off.



Part Name	How To Do	Descriptive Picture
Tray Drawer Box	<p><b>[Disassembly]</b></p> <ol style="list-style-type: none"> <li>1. Disassemble the TRAY FRE UP.</li> <li>2. Open the refrigerator door as much as possible.</li> </ol>	
	<p><b>[Disassembly]</b></p> <ol style="list-style-type: none"> <li>3. Hold the back of the BOX and lift it up.</li> </ol>	
	<p><b>[Disassembly]</b></p> <ol style="list-style-type: none"> <li>4. Turn the box upside down and disassemble it as it is.</li> </ol>	
	<p><b>[Assembly]</b></p> <ol style="list-style-type: none"> <li>1. Insert the TRAY DRAWER BOX from the front.</li> </ol>	
	<p><b>[Assembly]</b></p> <ol style="list-style-type: none"> <li>2. Place the back of the TRAY DRAWER BOX.</li> <li>3. Check if the ribs are assembled into the rail groove.</li> </ol>	
	<p><b>[Assembly]</b></p> <ol style="list-style-type: none"> <li>4. Check if it works.</li> </ol>	

 If you want to assembly, follow the reverse order.

# DISASSEMBLY AND REASSEMBLY

## 4-13) Door Bins

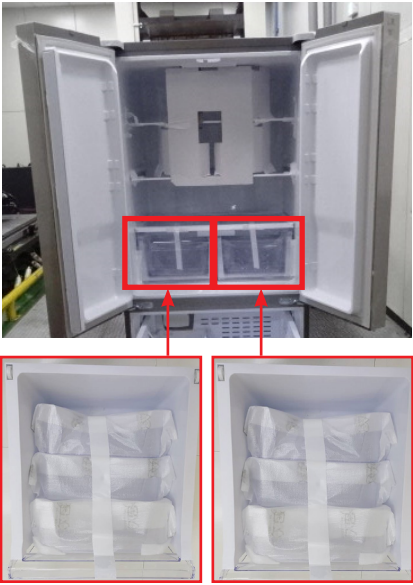
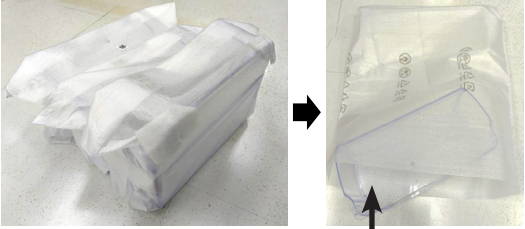
 When disassembling, make sure the unit turned off.

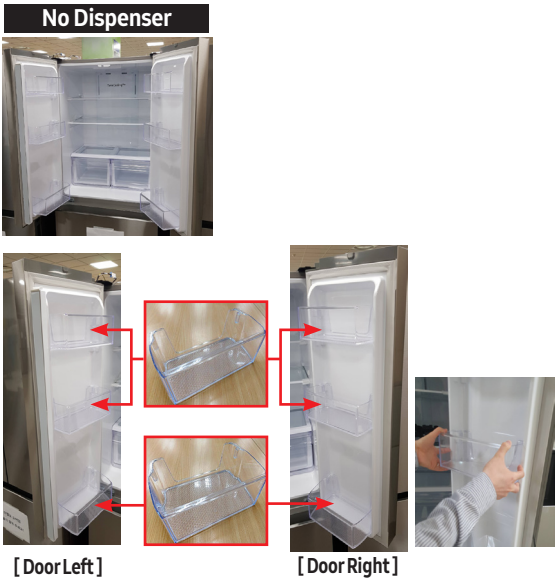
Part Name	How To Do	Descriptive Picture
	<p>1. Remove Door Bins from DRAWER-REF. (Refer to the picture)</p>	
<p>Door Bins</p>	<p>2. Remove Door Bins from BAG PE. (Refer to the picture)</p>	 <p style="text-align: right;"><b>Door Bins</b></p>
	<p>3. Lightly press and assemble to fit door bins position. (Refer to the picture)</p>	<div style="display: flex; justify-content: space-around;"> <div style="text-align: center;"> <p><b>Dispenser</b></p>  <p>[DoorLeft] [DoorRight]</p> </div> <div style="text-align: center;"> <p><b>No Dispenser</b></p>  <p>[DoorLeft] [DoorRight]</p> </div> </div>

 If you want to assembly, follow the reverse order.

## DISASSEMBLY AND REASSEMBLY

### 4-14) COVER EVAP-REF

 When disassembling, make sure the unit turned off.





Part Name	How To Do	Descriptive Picture
<b>COVER EVAP-REF</b>	<b>[Disassembly]</b> 1. Unscrew two screws. And remove the hook by pulling it from the lower part and pushing the cover down. (Refer to the picture)	

 If you want to assembly, follow the reverse order.

# DISASSEMBLY AND REASSEMBLY

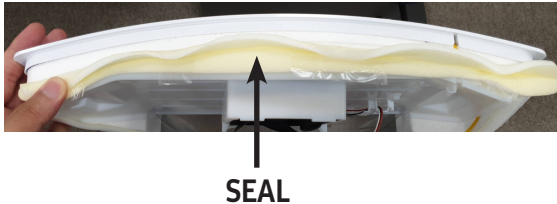
## 4-15) COVER EVAP-REF (With Sensor Temp)



 When disassembling, make sure the unit turned off.

Part Name	How To Do	Descriptive Picture
COVER EVAP-REF	<p>[Disassembly] 2. disassemble the Sensor Temp Housing.</p>	
	<p>[Disassembly] 3. Rip a SEAL in half.</p>	
	<p>[Disassembly] 3. Unscrew a screw and disassemble the Case motor.</p>	
	<p>[Disassembly] 4. Unwind the Sensor Temp Wire. (Yellow Wire)</p>	
	<p>[Assembly] 5. wind the Sensor Temp Wire. (Yellow Wire)</p>	

 If you want to assembly, follow the reverse order.

# DISASSEMBLY AND REASSEMBLY

 When disassembling, make sure the unit turned off.

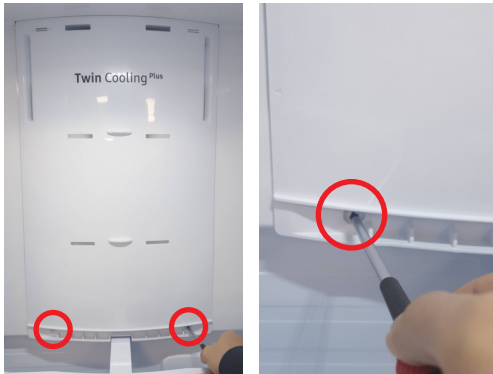

Part Name	How To Do	Descriptive Picture
COVER EVAP-REF	<p>[Assembly] 6. Screw a screw and assemble the Case motor</p>	
	<p>[Assembly] 7. Attach a SEAL in half</p>	
	<p>[Assembly] 8. Assemble the Sensor Temp Housing.</p>	
	<p>[Assembly] 9. Screw two screws. And assemble the hook by pulling it from the lower part and pushing the cover down. (Refer to the picture)</p>	

 If you want to assembly, follow the reverse order.

# DISASSEMBLY AND REASSEMBLY

## 4-16) Evaporator REF

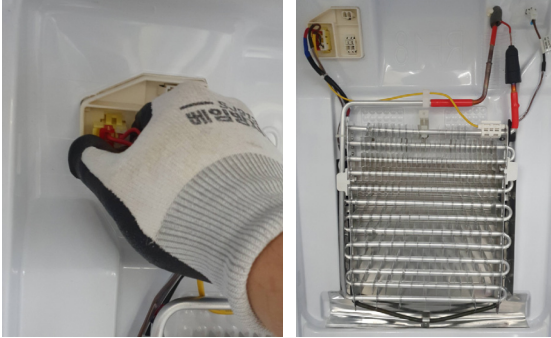
 When disassembling, make sure the unit turned off.



Part Name	How To Do	Descriptive Picture
	<p>1. Disconnect the housing wiring connector. (Refer to the picture)</p>	
<p>Evaporator REF</p>	<p>2. Cut the Evap pipe and Suction pipe &amp; Capillary Tube. Then remove the evaporator by Lifting the evaporator up and pulling the bottom out. (Refer to the picture)</p>	
	<p>3. If you want Assemble, do reverse this process.</p>	

 If you want to assembly, follow the reverse order.

# DISASSEMBLY AND REASSEMBLY

## 4-17) Evap (Sensor) REF

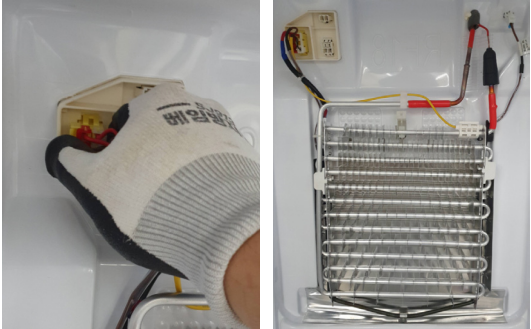
 When disassembling, make sure the unit turned off.

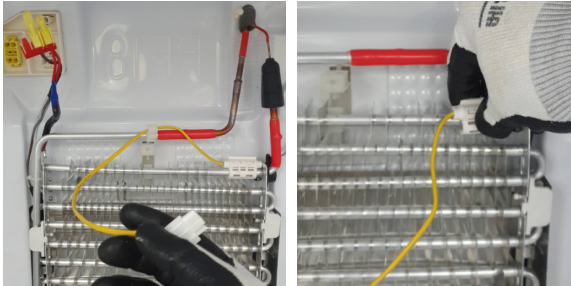



Part Name	How To Do	Descriptive Picture
Evaporator REF	1. Remove the hosing connector at the left.	
	2. Cut the Cable Tie.	
	3. Remove Sensor Housing from TPA. Then, Remove the Fixer wire and Fixer sensor.	
	4. If you want Assemble, do reverse this process.	

 If you want to assembly, follow the reverse order.

# DISASSEMBLY AND REASSEMBLY

## 4-18) COVER EVAP-FRE

 When disassembling, make sure the unit turned off.



Part Name	How To Do	Descriptive Picture
COVER EVAP-FRF	<p><b>[Disassembly]</b> 1. Unscrew two screws. And remove the hook by pulling it from the lower part and pulling the cover side. (Refer to the picture)</p>	
	<p><b>[Disassembly]</b> 2. Disassemble the Fan Motor Housing.</p>	
	<p><b>[Assembly]</b> 3. Assemble the Fan Motor Housing.</p>	
	<p><b>[Assembly]</b> 4. Screw two screws. And assemble the hook by pushing it from the lower part and pushing the cover down. (Refer to the picture)</p>	

 If you want to assembly, follow the reverse order.

# DISASSEMBLY AND REASSEMBLY

## 4-19) Evaporator FRE

 When disassembling, make sure the unit turned off.



Part Name	How To Do	Descriptive Picture
<p>Evaporator FRE</p>	<p>1. Disconnect the housing wiring connector. (Refer to the picture)</p>	
	<p>2. Cut the Evap Pipe and Suction Pipe welded points. Then, remove the evaporator by pulling the lower part of the evaporator out while lifting it up.</p>	
	<p>3. If you want Assemble, do reverse this process.</p>	

 If you want to assembly, follow the reverse order.

# DISASSEMBLY AND REASSEMBLY

## 4-20) Evap (Sensor Temp) FRE

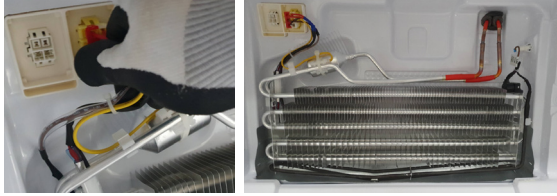
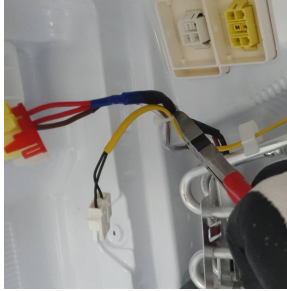
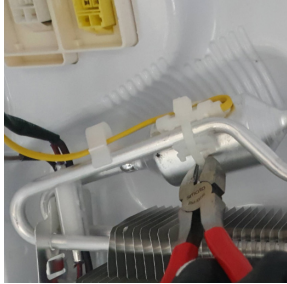
 When disassembling, make sure the unit turned off.



Part Name	How To Do	Descriptive Picture
Evaporator FRE	1. Remove the hosing connector at the left.	
	2. Disassemble Sensor Housing from TPA, then cut the Cable Tie.	
	3. Cut the Cable tie that tie Accumulator and Sensor.	
	4. Remove the sensor temp. If you want Assemble, do reverse this process.	

 If you want to assembly, follow the reverse order.

## DISASSEMBLY AND REASSEMBLY

### 4-21) Ice Maker (Freezer) (OPTION)

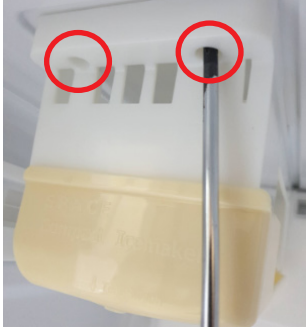
 When disassembling, make sure the unit turned off.





Part Name	How To Do	Descriptive Picture
Ice-Maker (FRE)	1. Remove the 2 screw.	
	2. Separate the HOUSING of the Ice Maker.	

 If you want to assembly, follow the reverse order.

# DISASSEMBLY AND REASSEMBLY

## 4-22) Water Dispenser (OPTION)

 When disassembling, make sure the unit turned off.

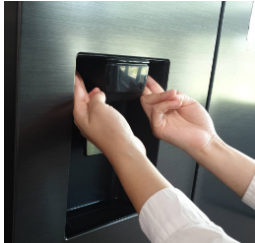
Part Name	How To Do	Descriptive Picture
Water Dispenser	<p><b>[Disassembly]</b> 1. Remove Bolts using (+) screwdriver. (2ea)</p>	
	<p><b>[Disassembly]</b> 2. Put your hand inside the cover and pull it forward.</p>	
	<p><b>[Disassembly]</b> 3. Disassemble the assy cover dispenser</p>	
	<p><b>[Assembly]</b> 1. Locate the assy cover dispenser at the dispenser</p>	
	<p><b>[Assembly]</b> 2. Press your hand on the back to get hooks. 3. Assemble screw bolts. (2ea)</p>	

 If you want to assembly, follow the reverse order.

## DISASSEMBLY AND REASSEMBLY

### 4-23) Water Tank (OPTION)

 When disassembling, make sure the unit turned off.

Part Name	How To Do	Descriptive Picture
Water Tank	1. Hold both sides of the water tank with hands and pull it forward.	
	2. If you want Assemble, do reverse this process.	

 If you want to assembly, follow the reverse order.

# DISASSEMBLY AND REASSEMBLY

## 4-24) Sensor In Freezer

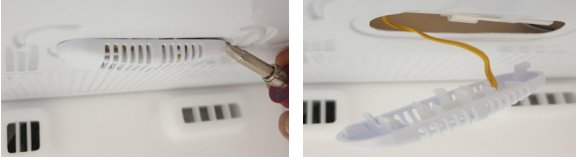
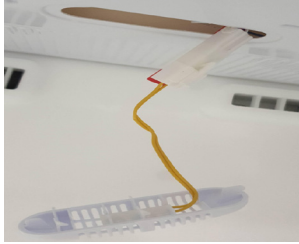
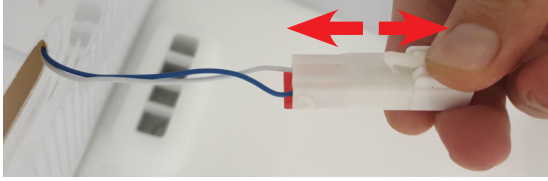
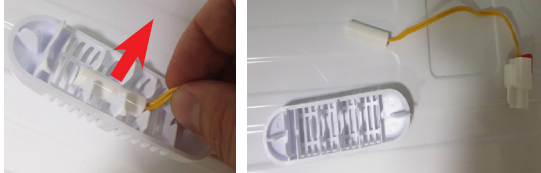
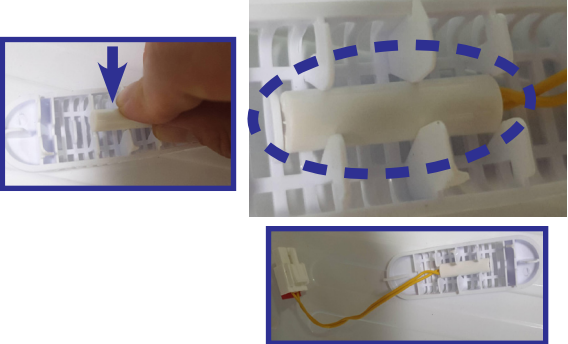

 When disassembling, make sure the unit turned off.

Part Name	How To Do	Descriptive Picture
Sensor In Freezer	<p><b>[Disassembly]</b> 1. Separate Cover Sensor on Liner by using Flat Head Driver.</p>	
	<p><b>[Disassembly]</b> 2. Pull out Cover and Wire Harness.</p>	
	<p><b>[Disassembly]</b> 3. Disconnect Connector.</p>	
	<p><b>[Disassembly]</b> 4. Pull out Sensor from Cover.</p>	
	<p><b>[Assembly]</b> 1. Put sensor in Cover.</p>	

 If you want to assembly, follow the reverse order.

# DISASSEMBLY AND REASSEMBLY

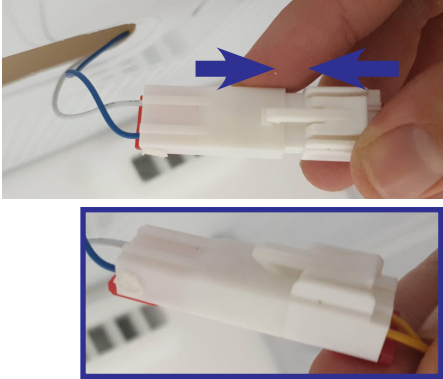
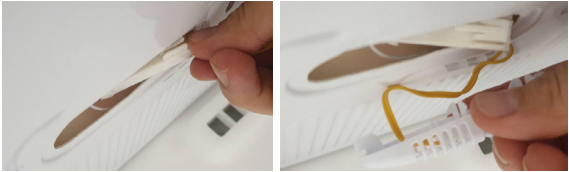
 When disassembling, make sure the unit turned off.

Part Name	How To Do	Descriptive Picture
Sensor In Freezer	<p>[Assembly] 2. Connect Sensor to Wire Harness.</p>	
	<p>[Assembly] 3. Put Connector and Wire In Liner.</p>	
	<p>[Assembly] 4. Assembly Cover to Liner.</p>	
	<p>[Assembly] 5. Check Assembly Cover Finally.</p>	 <p style="text-align: center;">Front View                      RearView</p>

 If you want to assembly, follow the reverse order.

# DISASSEMBLY AND REASSEMBLY

## 4-25) Comp Cooling Fan

 When disassembling, make sure the unit turned off.

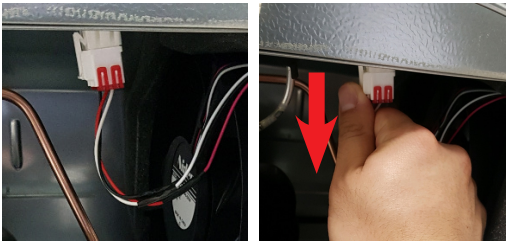
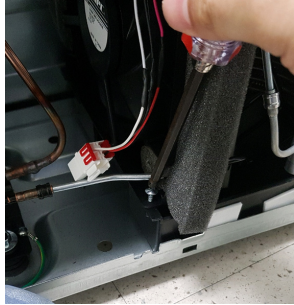
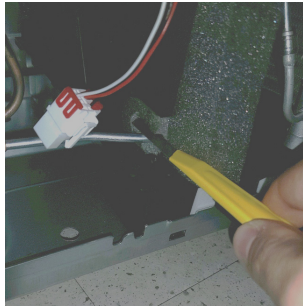
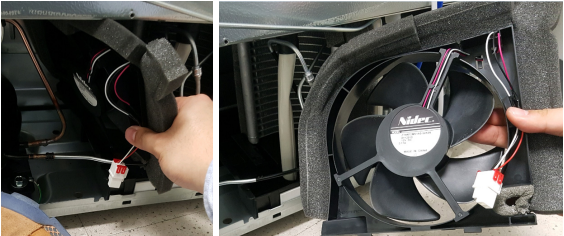
Part Name	How To Do	Descriptive Picture
<p><b>Motor pan</b></p>	<p>1. Remove 5 screws from the compressor cover.</p>	
	<p>2. Disengage the housing connector. (Refer to the picture)</p>	
	<p>3. Remove a screw which combine Fan and TRAY DRAIN-WATER.</p>	
	<p>4. Cutting the SEAL-SUPPORT MOTOR.</p>	
	<p>5. Pull the Fan and disassemble from TRAY DRAIN-WATER. And then, tilt Fan and pull it out.</p>	

 If you want to assembly, follow the reverse order.

# DISASSEMBLY AND REASSEMBLY

## 4-26) Compressor

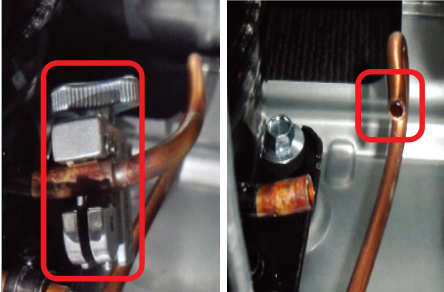
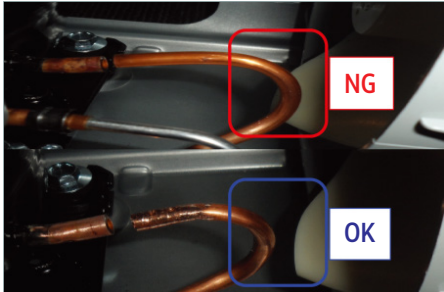

 When disassembling, make sure the unit turned off.

Part Name	How To Do	Descriptive Picture
Compressor	<p>1. Sand Paper Process</p> <ul style="list-style-type: none"> <li>- Use the Sand Paper to make the left part of the weld metaled metal smooth.</li> <li>- Use the Sand Paper to make the right part of the welded metal smooth.</li> </ul>	
	<p>2. Pipe Cutting Process</p> <ul style="list-style-type: none"> <li>- Using the pipe cutter, cut both welded parts. (Straight section should be at least 25mm)</li> </ul>	
	<p>3. Connect, Suc. Bending process - Bend Connect, and Suc. to make a straight line with the Comp Pipe. (Make sure Connect, and Suc. do not interrupt the Fan after the Bending process)</p>	





CAUTION

This appliance contains a small amount of isobutane refrigerant (R-600a), a natural gas with high environmental compatibility that is, however, also flammable. When transporting and installing the appliance, care should be taken to ensure that no parts of the refrigerating circuit are damaged.

Compressor	<p>4. Check Service Ring specifications of the Pipe</p>	
	<p>5. Applying Lokprep and connecting the Service Ring_1 - Before applying Lokprep, remove any foreign substances on the pipe surface with Sand Paper- Apply 0.05g of Lokprep onto the Comp Pipe- Insert the Service Ring in the Comp Pipe and fasten it by screwing it 360° 2 times.</p>	

## DISASSEMBLY AND REASSEMBLY

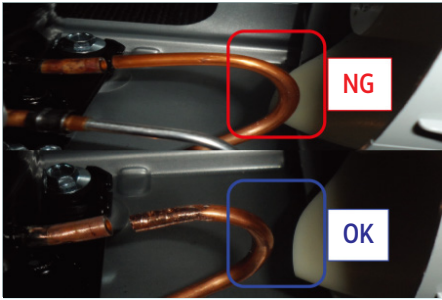
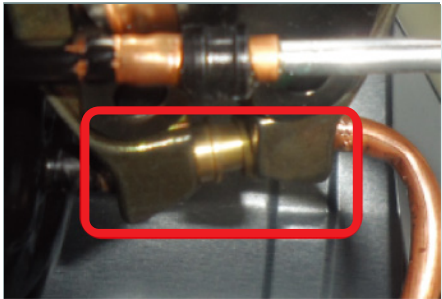
 When disassembling, make sure the unit turned off.

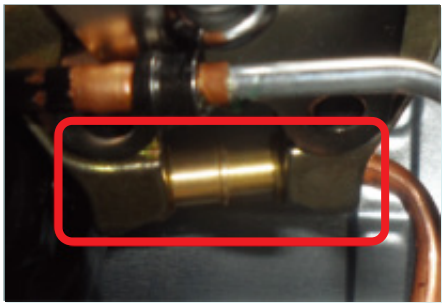

Part Name	How To Do	Descriptive Picture
Compressor	6. Applying Lokprep and connecting the Service Ring_2 - Apply 0.05g of Lokprep onto the pipe - Insert the service ring into the Connect, Suc. pipe and fasten it by screwing it 360° 2 times.	
	7. Installing manual Lokring Tool - Install manual Lokring Tool on the Service Ring.	
	8. Fastening Service Ring - Press the ring with the Lokring tool. - When fastening, press the ring multiple times slowly until the ring is fastened in the middle. (DO NOT PRESS IT ONCE TO THE END.)	
	9. Check the Service Ring connection status.	

 If you want to assembly, follow the reverse order.

# DISASSEMBLY AND REASSEMBLY

## 4-27) Machine Compartment

 When disassembling, make sure the unit turned off.



Part Name	How To Do	Descriptive Picture
Relay O/L	1. Remove Cover Relay.	
	2. Disassemble Housing Connector from Comp.	

 If you want to assembly, follow the reverse order.

# DISASSEMBLY AND REASSEMBLY

## 4-28) Electric Box (PBA Main)

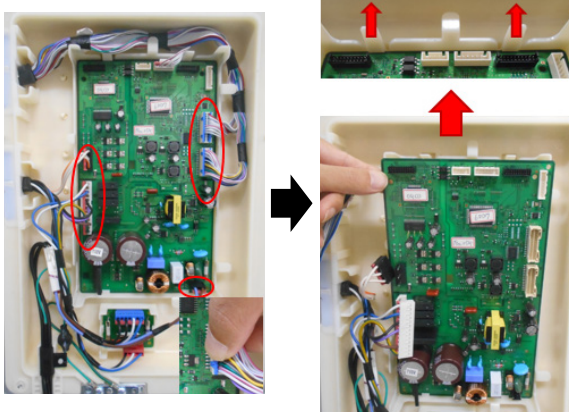
 When disassembling, make sure the unit turned off.

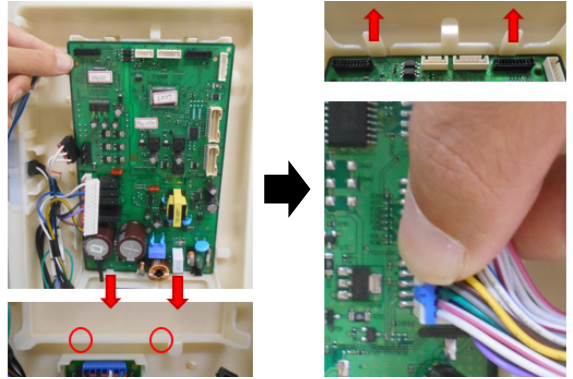
Part Name	How To Do	Descriptive Picture
	<p><b>[Disassembly]</b></p> <p>1. Loosen screw 4ea on Cover PCB with the (+)screwdriver and Open.</p> <p> <b>CAUTION</b> Be sure to unplug the power cord before performing the operation above.</p>	
PBA Main	<p><b>[Disassembly]</b></p> <p>2. Unsnap connectors of PCB.</p> <p>3. Push 2 hooks to upside and pull out PCB outside.</p>	
	<p><b>[Assembly]</b></p> <p>1. Insert PCB low side in the 2ea fixer.</p> <p>2. Push 2 hooks to upside and push PCB in the hooks.</p> <p>3. Snap the connectors of PCB.</p> <p> <b>CAUTION</b> Be sure to unplug the power cord before performing the operation above.</p>	

 If you want to assembly, follow the reverse order.

## DISASSEMBLY AND REASSEMBLY

### 4-29) Electric Box (PBA Main)

 When disassembling, make sure the unit turned off.

Part Name	How To Do	Descriptive Picture
PBA Main	<p>[Assembly]</p> <p>4. Assemble Cover PCB and fasten screw 4ea with the (+) screwdriver.</p>	

 If you want to assembly, follow the reverse order.

### 4-30) Electric Box (Fuse Block)

 When disassembling, make sure the unit turned off.

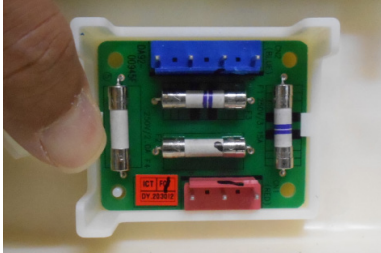

Part Name	How To Do	Descriptive Picture
Fuse Block	<p>4. (Fuse Block PBA) Press the locking hook down and remove the Fuse Block PBA by pulling it out. (Refer to the picture)</p>	

 If you want to assembly, follow the reverse order.

# DISASSEMBLY AND REASSEMBLY

## 4-31) Cover-Display

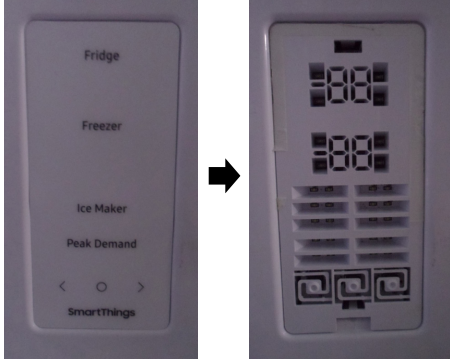
 When disassembling, make sure the unit turned off.

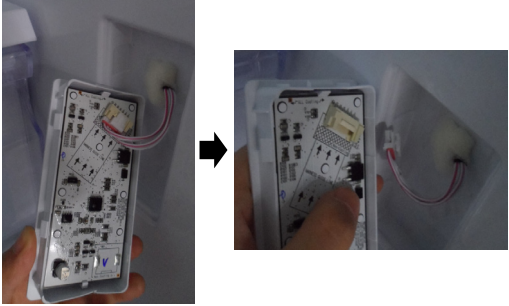
Part Name	How To Do	Descriptive Picture
Cover-Display	1. Remove the Inlay.	
	2. Push between RELECTOR and LINER with (-) screwdriver. - Insert the screwdriver vertically to the end.	
	3. Tilt the screwdriver down and pull the display.	 <p style="text-align: center;"><b>Tilt Down</b></p>
	4. Disconnect Housing.	
	5. If you want Assemble, do reverse this process.	

 If you want to assembly, follow the reverse order.

## 5. CHECK THE INSTALLATION STATUS

### 5-1) Function for failure diagnosis

#### 5-1-1. Test mode (manual operation / manual defrost function)

- Press the '<' and '>' buttons at the same time for at least 6 seconds. The Control Display will blink with an interval of 0.5 seconds. In that case, you may take your fingers off both buttons and press the '>' button to enter the Engineer Mode. After entering Engineer Mode, press the '<' or '>' key to make the number '1' blinks. Then, press the 'O' button to enter the Test Mode.

Engineer Mode	
No.	Name
1	Test Mode
3	Self-diagnostic Function
6	MAC Address Display Mode (Wi-Fi Only)
7	Load Condition Display Mode
9	Option Setting Mode

[ Mode list selectable in Engineer Mode ]

- If any key on the front of panel is pressed within 15 seconds after the test mode, it will be operated as below sequence : Manual Operation1(FF) → Manual Operation2(OF r) → Manual Defrost of fridge compartment (rd) → Manual Defrost of fridge and freezer compartments (Fd) → Cancellation (normal operation, Display all off) → Manual Operation1(FF)
- If any key on the front of panel is not pressed within 15 seconds after the test mode, the test mode will be canceled and it will be returned to previous mode.

## CHECK THE INSTALLATION STATUS

### 1) TEST Mode Entering

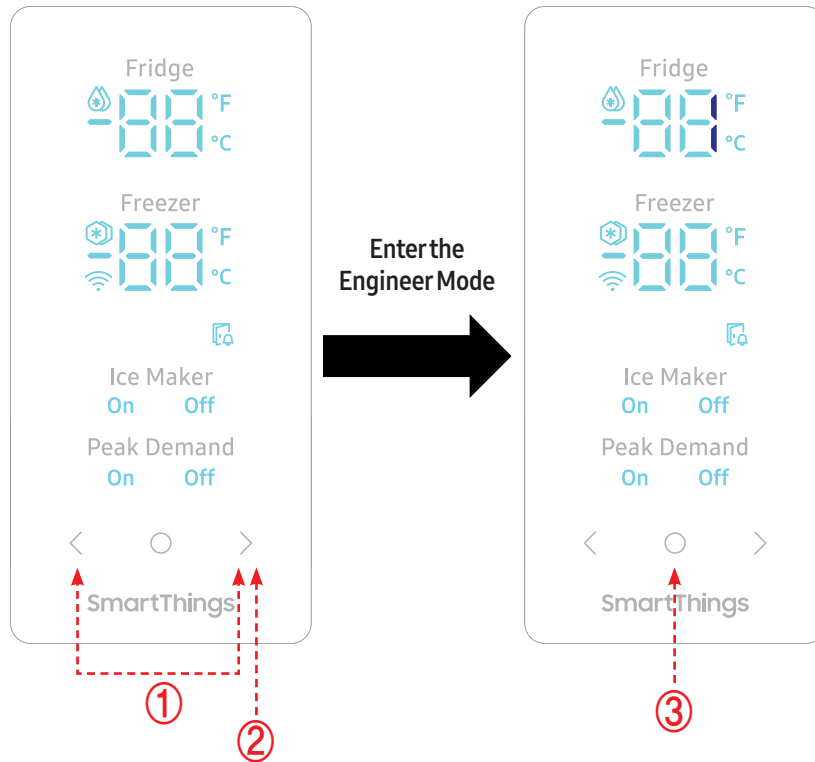

'<' + '>' Key are pressed simultaneously for 6 seconds.

And the Control Display will blink with an interval of 0.5 seconds.

In that case, you may take your fingers off both buttons and press the '>' button to enter the Engineer Mode.

After entering Engineer Mode, press the '<' or '>' key to make the number '1' blinks.

Then, press the 'O' button to enter the Test Mode.

## CHECK THE INSTALLATION STATUS

### 2) Forced Operating Function

- 2-1) If any key is pressed once in test mode, blinks "FF" on the display and it indicates the refrigerator has entered the manual operation. At this moment, buzzer beeps as an alarm.
- 2-2) If any key is pressed once at the manual operation1 status, OF-r will be displayed. FF and OF-r means manual operation 1 and 2 separately. These 2 functions operate with same RPM of COMP.

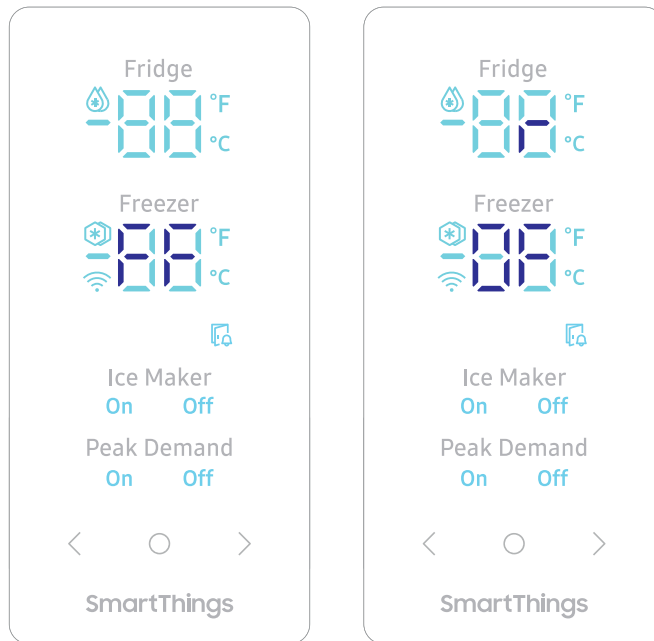

- 2-3) If manual operation is selected, compressor will run at once without 7 minutes delay in any mode. If the refrigerator is on the defrost cycle at the moment, defrost will be finished and manual operation will begin. (Be careful if manual operation get started at the moment of compressor off, over load could be occurred.)

DISPLAY		Operating Time	Comp.	Fan		
Freezer	Fridge			C	F	R
FF	-	24Hr	ON	ON	ON	The Temperature is controlled
OF	r	24Hr	ON	ON	ON	The Temperature is controlled

- 2-4) If manual operation works, compressor & f-fan operate continuously for 24 hours and fresh food compartment will be controlled by the setting temperature.
- 2-5) When the manual operation runs, setting temperature will be selected automatically as below : freezer temperature -8°F(-23°C), fridge temperature 34°F(1°C).
- 2-6) During manual operation, Power Freezer & Power Cool function will not be work.If a function is selected, the power function icon of the selected function will be off automatically after 10 seconds.
- 2-7) Manual operation can be canceled by removing power from the unit, then resupplying power.
- 2-8) Alarm(0.25 sec ON/ 0.75 sec OFF) will beep continuously until manual operation is completed and there is no function to make the sound stop.

## CHECK THE INSTALLATION STATUS

### 3) Forced Defrost

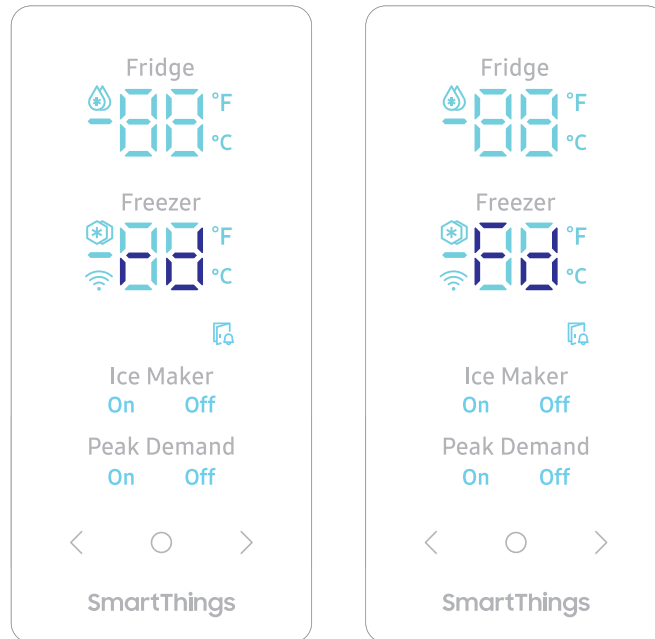

- 3-1) When you press any key one more time at Manual Operation2 [OF r], rd lights up on the Display Panel. At this time, the Manual Operation stops immediately and R-Defrost will be performed at the same time.
- 3-2) When you press any key one more time at Forced R-Defrost [rd], Fd lights up on the Display Panel. At this time, FR-Defrost will be performed at the same time.
- 3-3) At this time, it will send out "Beep" sound for 2 seconds and then it will perform Forced F/R Defrost while sending out "0.5 sec On and 0.5 sec Off" sound.

### 4) Test cancel mode

- 4-1) During the simultaneous defrosting of fresh food and freezer compartments, if the display panel change to the test mode and test button is pressed one more time, defrosting of fresh food and freezer compartments will be canceled and the unit will return to the normal operation.  
Or, all test functions will be canceled by turning main power ON and OFF.

## CHECK THE INSTALLATION STATUS

### 5-1-2. Self-diagnostic function

#### 1) Self-diagnostic function in the Initial power ON

- 1-1) Micom operates self-diagnostic function to check the temperature sensor condition within 1 second when the refrigerator turned On initially.
- 1-2) If bad sensor is detected by the self-diagnostic function, the applicable display LED will blink for 0.5 sec. At this moment, there is no beep sound.(Refer to self-diagnostic CHECK LIST)
- 1-3) Self-diagnostic button is recognized only when the error is displayed by the bad sensor.Display does not operate normally but temperature control will be controlled by the emergency operation.
- 1-4) When the error is detected by self-diagnosis, the error can be canceled automatically if all troubled sensors are corrected or Self-diagnostic function key ('<' + '>') are pressed simultaneously for **12 seconds**.  
(Return to normal display mode)

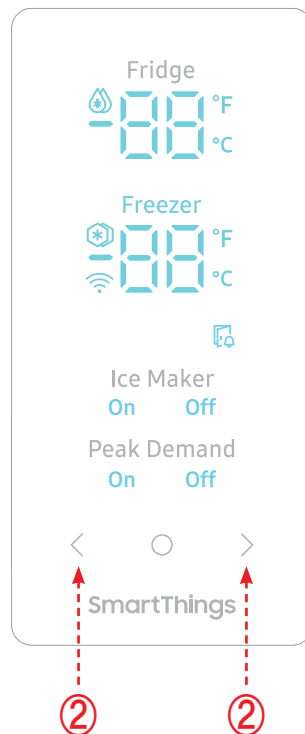

① If '<' Key + '>' Key are pressed simultaneously for **12 seconds**, the error mode by self-diagnosis will be canceled.

## CHECK THE INSTALLATION STATUS

### 2) Self-diagnostic function during normal operation

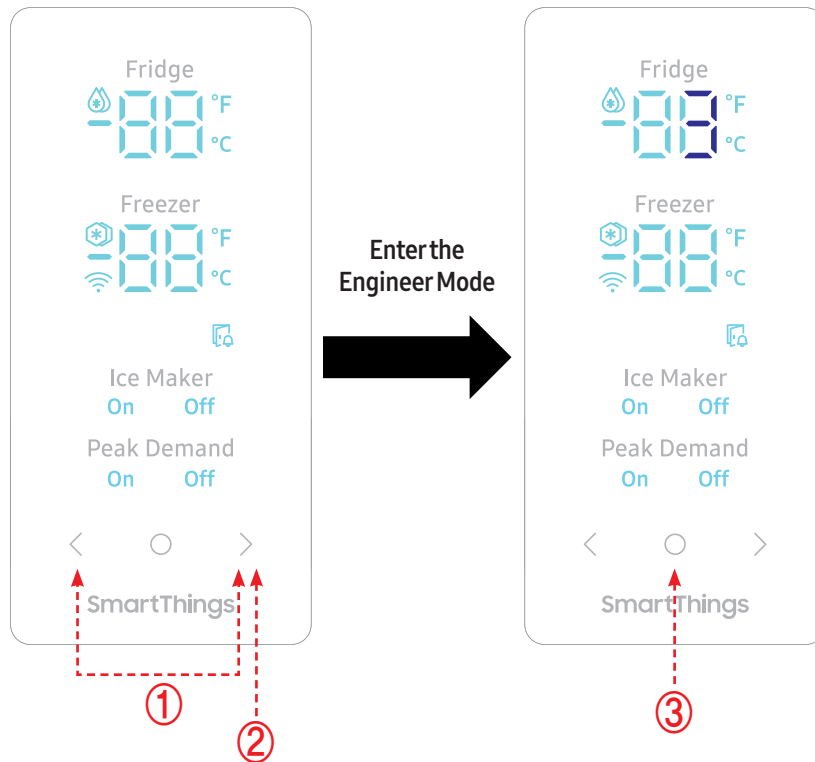













② '<' + '>' Key are pressed simultaneously for 6 seconds.  
And the Control Display will blink with 0.5 second interval for 4 seconds.  
In that case, you may take your fingers off both buttons and press the '>' button to enter the Engineer Mode.  
After entering Engineer Mode, press the '<' or '>' key to make the number '3' blinks.  
Then, press the 'O' button to enter the self-diagnosis function.

- 2-1) If '<' + '>' are pressed simultaneously for 6 seconds during normal operation, the temperature setting display will operate for 4 seconds (ON/OFF 0.5sec each).  
In that case, you may take your fingers off both buttons and press the '>' button to enter the Engineer Mode. After entering Engineer Mode, press the '<' or '>' key to make the number '3' blinks. Then, press the 'O' button to enter the self-diagnosis function..
- 2-2) At this moment, self-diagnostic function will be returned with buzzer sound 'ding-dong'.  
If there is an error, display of error will be operated for 30 seconds and then return to normal condition whether problem is corrected or not.  
(Refer to self-diagnosis CHECK LIST)
- 2-3) Input by button is not accepted during self-diagnostic function.

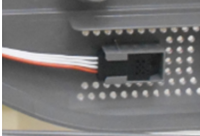

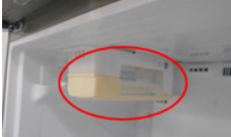

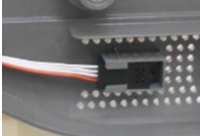





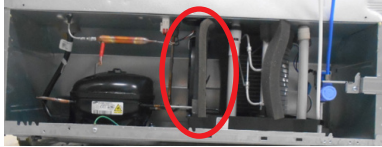

# CHECK THE INSTALLATION STATUS

## \* Self-diagnosis CHECK LIST

LED		Item	Diagnostic method	Location image	
F	R				
88		Freezer Sensor	The voltage of MAIN PCB CN51-"9" ↔ "11" : shall be between 4.5V~1.0V		
88		Fridge Sensor	The voltage of MAIN PCB CN51-"14" ↔ "13" : shall be between 4.5V~1.0V		
88		Freezer compartment defrosting sensor	The voltage of MAIN PCB CN51-"5" ↔ "7" : shall be between 4.5V~1.0V.		
88	88	Fridge compartment defrosting sensor	The voltage of MAIN PCB CN51-"12" ↔ "13" : shall be between 4.5V~1.0V.		
88		External air sensor	The voltage of MAIN PCB CN51-"4" ↔ "6" : shall be between 4.5V~1.0V		
88		Ice Maker (Freezer) Sensor Error (OPTION)	The voltage of MAIN PCB CN30-"9" ↔ "11" : shall be between 4.5V~1.0V		
88		Humidity sensor	The voltage of MAIN PCB CN51-"4" ↔ "8" : shall be between 4.5V~1.0V		



# CHECK THE INSTALLATION STATUS

## \* Self-diagnosis CHECK LIST

LED		Item	Diagnostic method	Location image	
F	R				
21		Freezer Fan Error	The voltage of MAIN PCB CN51-"17" ↔ "19" : shall be between 7V~12V		
22		Fridge Fan Error	The voltage of MAIN PCB CN51-"18" ↔ "20" : shall be between 7V~12V		
23		C-Fan Error	The voltage of MAIN PCB CN51-"23" ↔ "25" : shall be between 7V~12V		
24	24	Freezer Defrosting Error	After separating MAIN PCB CN70 wire from PCB, resistance value between CN70-"3" ↔ "1" shall be 63(230) ohm +8%. (Resistance value is varied by input power.) 0 ohm : heater short ∞ ohm : wire/bimetal open (Must power off)		
25		Fridge Defrosting Error	After separating MAIN PCB 70 wire from PCB, resistance value between CN70-"5" ↔ "1" shall be 132 ohm ± 7%. (Resistance value is varied by input power.) 0 ohm : heater short ∞ ohm : wire/bimetal open (Must power off)		
26		Ice Maker (Freezer) Function Error (OPTION)	After changing the Ice Maker(F), plug the refrigerator power code again, and check the operation.		
33		Freezer Ice Pipe Heater Error (OPTION)	After separating MAIN PCB CN30 wire from PCB, resistance value between CN30-"5" ↔ "7" shall be 63(230) ohm ± 7%. (Resistance value is varied by input power) 0 ohm : heater short, ∞ ohm : wire/bimetal open (Must power off)		



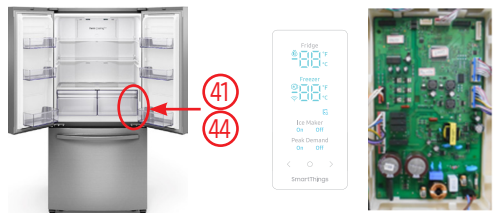
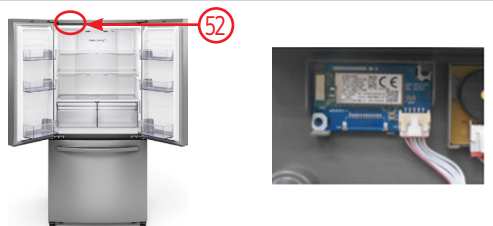

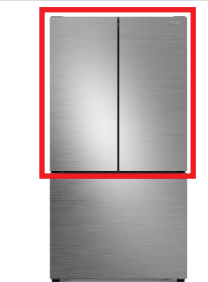
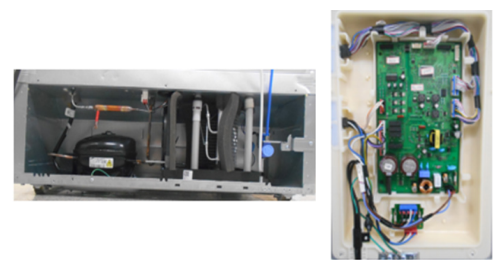





# CHECK THE INSTALLATION STATUS

## \* Self-diagnosis CHECK LIST

LED		Item	Diagnostic method	Location image
F	R			
88		Main ↔ Panel (F-HUB) Communication Error	Actually, If there is not a problem, it is desirable to replace Main and Panel PCB With the oscilloscope after a cable problem confirming.	
88		Main ↔ Inverter Communication Error	Actually, If there is not a problem, it is desirable to replace Main and Inverter PCB With the oscilloscope after a cable problem confirming.	
88		Main ↔ Wifi module Communication Error	Actually, If there is not a problem, it is desirable to replace Main and WiFi PCB With the oscilloscope after a cable problem confirming.	
88	88	The Freezer compartment abnormal high-temperature indicator blinks	Check if the door has been open for a long time or if hot food has been stored in the compartment. If the reason for the error is removed, the error code disappears after a pre-determined period of time.	
88	88	The Fridge compartment abnormal high-temperature indicator blinks		
88		Comp start failure error	Check if there is a short between compressor terminals. Check IPM Voltage [Under 13.5V] Check if there is a short between IPM Pins [#1~33]	
88		Comp IPM Fault Error	Check the soldering status of the inverter PCB. (Check if any parts have short-circuited). Check the Compressor and the Cycle.	

# CHECK THE INSTALLATION STATUS

## \* Self-diagnosis CHECK LIST

LED		Item	Diagnostic method	Location image	
F	R				
88		Comp location detection error	<p>Check the Compressor connections .</p> <p>Check the voltage of Resistance of R2 [0.090hm]</p> <p>Check the soldering status of the MAIN PCB. (Check if any parts have short-circuited)</p> <p>Check the Compressor and the Cycle.</p>		
84		Comp motor constraint error	<p>Compressor locking Error.</p> <p>Check the Compressor and the Cycle.</p> <p>Check the compressor wire connections.</p>		
88	88	Comp low voltage error	<p>Check the input voltage.</p> <p>- AC 60V (Input Power AC110~127V)</p> <p>- AC 106V (Input Power AC 220~240V)</p> <p>Check PCB bottom side soldering state.</p>		
88		Comp over voltage error	<p>Check the input voltage.</p> <p>- AC 155V (Input Power AC110~127V)</p> <p>- AC 310V (Input Power AC 220~240V)</p> <p>Check PCB bottom side soldering state.</p>		
88		Comp IPM Shut Down Error	<p>Check the soldering status of the inverter PCB. (Check if any parts have short-circuited).</p> <p>Check IPM, PBA case, Compressor Temperature.</p> <p>If IPM or Discrete IC Temperature 120°C over, blinking LED.</p>		

## CHECK THE INSTALLATION STATUS

### 5-1-3. Display function of Load condition

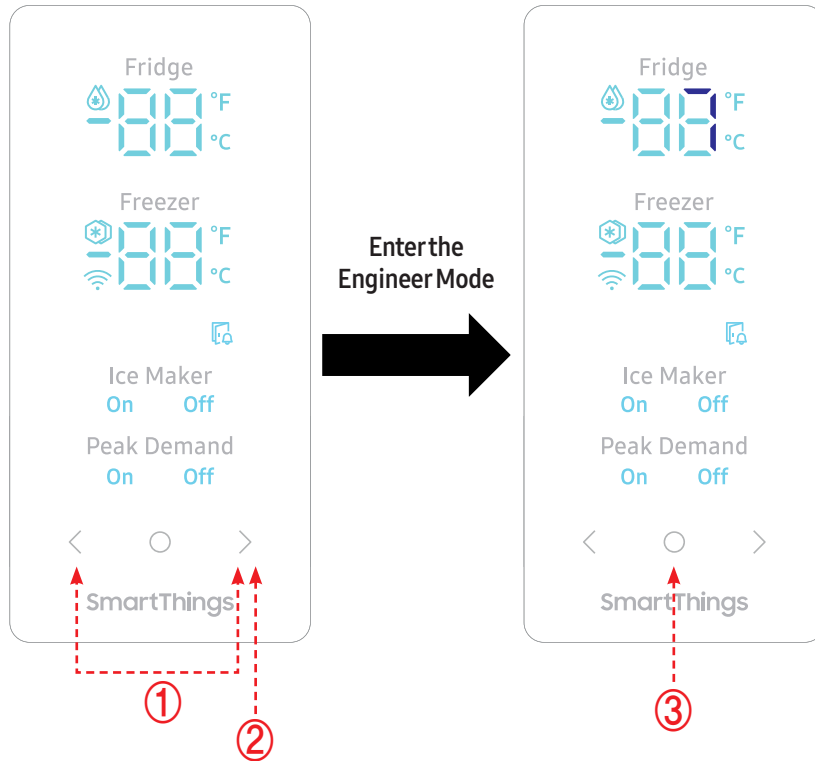

- ① '<' + '>' Key are pressed simultaneously for 6 seconds. And the Control Display will blink with 0.5 second interval for 4 seconds.
- ② In that case, you may take your fingers off both buttons and press the '>' button to enter the Engineer Mode.
- ③ After entering Engineer Mode, press the '<' or '>' key to make the number '7' blinks.
- ④ Then, press the 'O' button to enter the Load Condition Display Mode.

- 1) If the '<' and '>' button are pressed simultaneously for 6 seconds during normal operation, the temperature setting display of Fridge and freezer compartments will blink ALL ON/OFF with 0.5 for 4 seconds. In that case, you may take your fingers off both buttons and press the '>' button to enter the Engineer Mode.
- 2) After entering Engineer Mode, press the '<' or '>' key to make the number '7' blinks. Then, press the 'O' button to enter the Load Condition Display Mode. At LED all on state, only load condition display will blink ON/OFF with 0.5 seconds interval.
- 3) Load condition display mode shows the load that micom signal is outputting.  
However, It means that micom signal is outputting, it does not mean whether load is operating or not. That is to say that though load operation is displayed, load could not be operated by actual load error or PCB relay error etc.  
(This function would be applied at A/S.)
- 4) Load condition display function will maintain for 30 seconds and then normal condition will be returned automatically.
- 5) Load condition display is as below. Only the load control LED will blink with 0.5interval in "Display LED".

## CHECK THE INSTALLATION STATUS

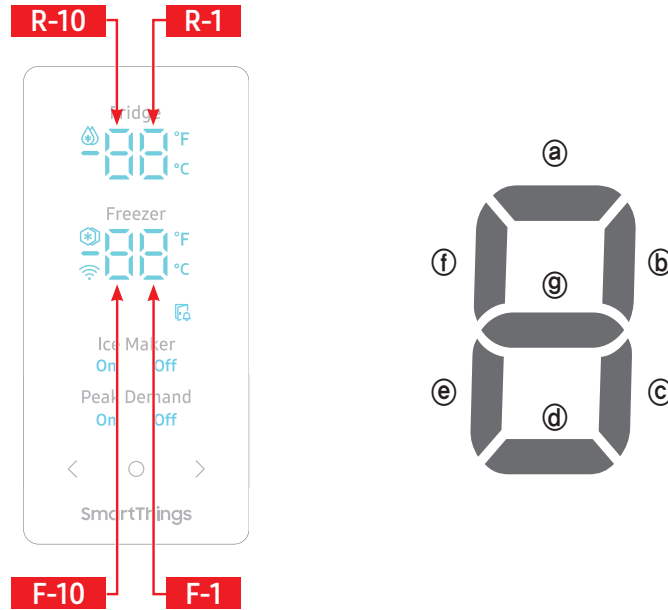

### \* R Load mode Check list

No.	Part	Display (LED)	Description
1	R-FAN HIGHEST	R-1 "a", "b"	In the case of the R-FAN HIGHEST operation, the corresponding LED is blinked.
2	R-FAN HIGH	R-1 "a"	In the case of the R-FAN HIGH operation, the corresponding LED is blinked.
3	R-FAN LOW	R-1 "b"	In the case of the R-FAN LOW operation, the corresponding LED is blinked.
4	R compartment defrost heater	R-1 "c"	In the case of the R compartment defrost heater operation, the corresponding LED is blinked.
5	High Temperature	R-1 "e"	If the external air temperature is 34°C or higher, the corresponding LED is blinked.
6	Low Temperature	R-1 "f"	If the external air temperature is 21°C or less, the corresponding LED is blinked.
7	Normal Temperature	R-1 "e", "f"	If the external air temperature is within the range of 22°C ~ 33°C, the corresponding LED is not blinked.
8	Demo Mode	R-1 "g"	In the case of the Demo mode operation, the corresponding LED is blinked.
9	Full Ice (Freezer)	R-10 "e"	In the case of the Freezer Ice maker's bucket is full, the corresponding LED is blinked.
10	Freezer Ice Pipe Heater	R-10 "f"	In the case of Freezer Ice Pipe Heater operation, the corresponding LED is blinked.
11	French Heater	F-10 "g"	In the case of the French heater operation, the corresponding LED is blinked.
12	Comp.	F-1 "a"	In the case of the Comp. operation, the corresponding LED is blinked.
13	F-FAN HIGHEST	F-1 "b", "c"	In the case of the F-FAN HIGHEST operation, the corresponding LED is blinked.
14	F-FAN HIGH	F-1 "b"	In the case of the F-FAN HIGH operation, the corresponding LED is blinked.
15	F-FAN LOW	F-1 "c"	In the case of the F-FAN LOW operation, the corresponding LED is blinked.
16	F compartment defrost heater	F-1 "d"	In the case of the F compartment defrost heater operation, the corresponding LED is blinked.
17	C-FAN HIGHEST	F-1 "e", "f"	In the case of the C-FAN HIGHEST operation, the corresponding LED is blinked
18	C-FAN HIGH	F-1 "e"	In the case of the C-FAN HIGH operation, the corresponding LED is blinked
19	C-FAN LOW	F-1 "f"	In the case of the C-FAN LOW operation, the corresponding LED is blinked
20	WIFI Status	WI-FI Icon	Not connected to the IP sharer (AP) or the Internet : Off
			Router(AP) connected : On
			Internet connected : On

## CHECK THE INSTALLATION STATUS

### 5-1-4. DEMO MODE1 : Cooling OFF Mode setting function (North America model)

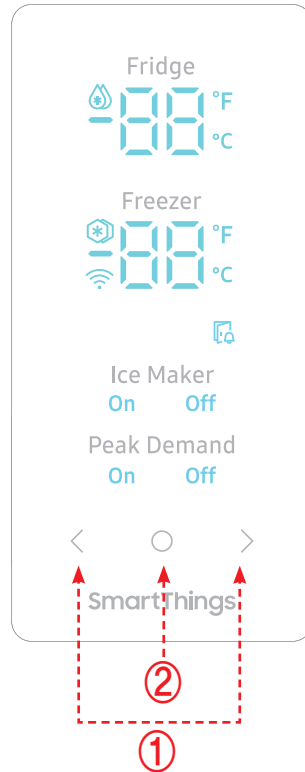

① Press the '**<**' and '**>**' buttons at the same time for at least 6 seconds.

The Control Display will blink with an interval of 0.5 seconds. In that case, you may take your fingers off both buttons and press the '**O**' button to enter the Cooling Off Mode.

- 1) Cooling Off mode will be started with buzzer sound(ding-dong).
- 2) If the cooling off mode key is pressed once more time during the cooling off operation, Cooling Off mode will be canceled.
- 3) If Cooling Off mode is selected, blinks "O-FF" on the temperature setting display of the panel and it indicates the refrigerator has entered the Cooling Off mode.
- 4) During Cooling Off mode, Fridge or Freezer compartments sensors are higher than 149°F (65°C) Cooling Off mode will be canceled automatically and freezing operation will be returned. (There is no buzzer sound when the Cooling Off mode is canceled by the temperature)
- 5) Operation contents of Cooling Off mode
  - Display, Fan motor and etc operate normally, not to operate compressor only.
  - Defrost is not operated. (including french heater)
  - Display function of the initial real temperature is finished.
  - Under the condition of Cooling Off mode, Cooling Off mode will be operated when Power On after Power OFF.

## CHECK THE INSTALLATION STATUS

### 5-1-5. DEMO MODE 2 : Exhibition Mode setting function (All regions except for North America)

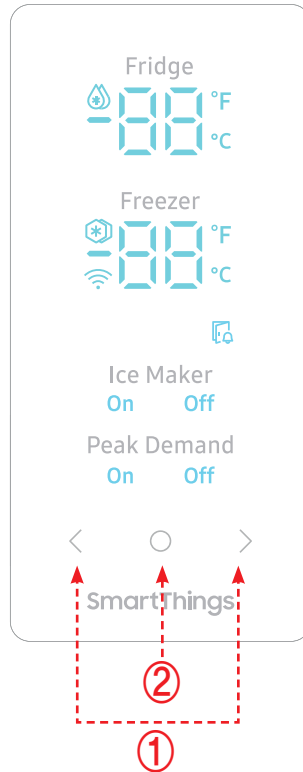

① Press the '<' and '>' buttons at the same time for at least 6 seconds. The Control Display will blink with an interval of 0.5 seconds. In that case, you may take your fingers off both buttons and press the 'O' button to enter the Exhibition Mode.

#### 1) Exhibition Mode setting function

- 1-1) Exhibition Mode will be started with buzzer sound(ding-dong).
- 1-2) If the Exhibition mode key is pressed once more time during the cooling off operation, Exhibition Mode will be canceled.
- 1-3) If Exhibition mode is selected, displays "on" or "oF" for 5 seconds on the temperature setting display of the panel and it indicates the refrigerator has entered or exited the Exhibition mode. After 5 seconds, the display panel will work normally.
- 1-4) During Exhibition mode, if fridge or freezer compartments sensors are higher than 149°F (65°C) Exhibition mode will be canceled automatically and freezing operation will be returned. (There is no buzzer sound when the Exhibition mode is canceled by the temperature)
- 1-5) Operation contents of Exhibition mode
  - Display, Fan motor and etc operate normally, not to operate compressor only.
  - Defrost is not operated. (including french heater)
  - Display function of the initial real temperature is finished.
  - Under the condition of Exhibition mode, Exhibition mode will be canceled when Power On after Power OFF.

## CHECK THE INSTALLATION STATUS

### 5-1-6. Option setting function

- Press the '<' and '>' buttons at the same time for at least 6 seconds. The Control Display will blink with an interval of 0.5 seconds for 4 seconds. In that case, you may take your fingers off both buttons and press the '>' button to enter the Engineer Mode. After entering Engineer Mode, press the '<' or '>' key to make the number '9' blink. Then, press the '0' button to enter the Option Setting Mode.

#### KEY operation method for changing to option mode

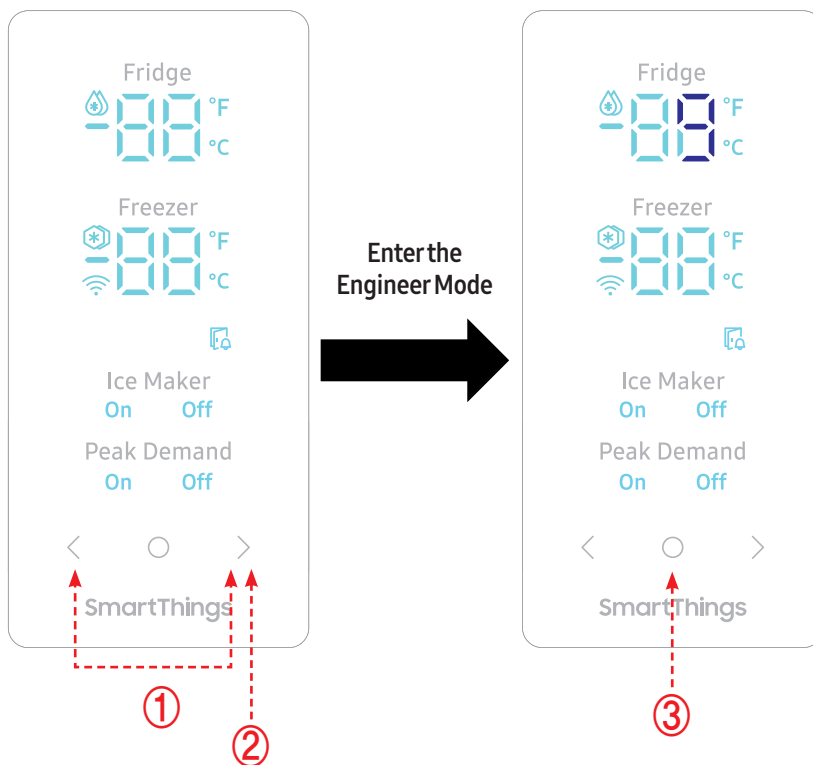

- '<' + '>' Key are pressed simultaneously for 6 seconds. And the Control Display will blink with 0.5 second interval for 4 seconds.
- In that case, you may take your fingers off both buttons and press the '>' button to enter the Engineer Mode.
- After entering Engineer Mode, press the '<' or '>' key to make the number '9' blink.
- Then, press the '0' button to enter the Option Setting Mode.

# CHECK THE INSTALLATION STATUS

## KEY control method after converting to option mode

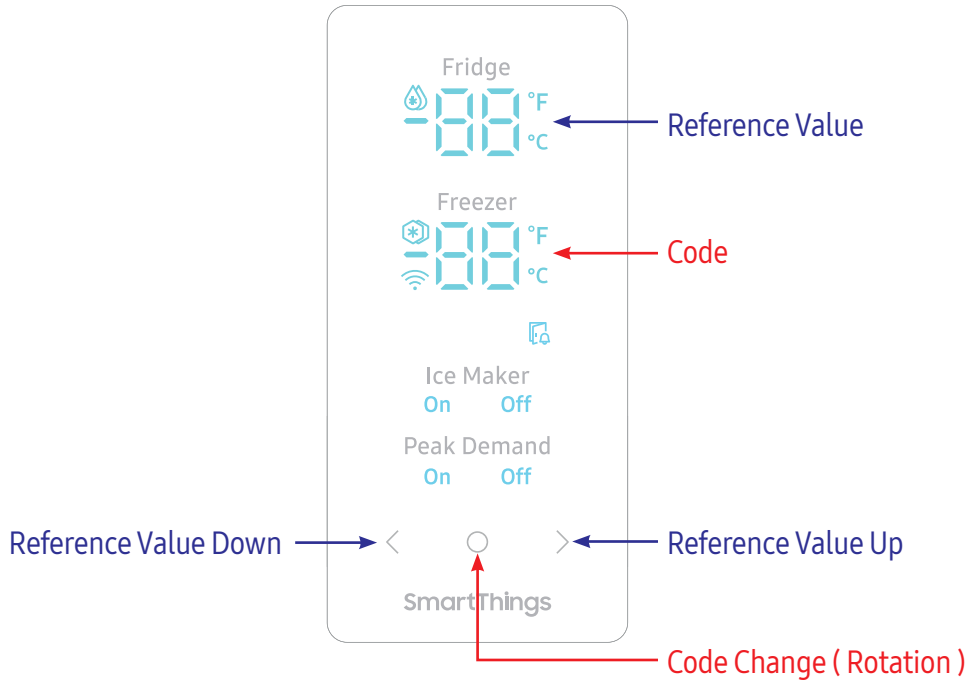

### ※ Key control in option mode

0	Code Change Key(Rotation)
<	Reference Value down key
>	Reference Value Up key

## CHECK THE INSTALLATION STATUS

- If the display changes to option setting mode, all displays will be off except freezer and fridge compartments temperature display as below. (Fridge and freezer compartments case will be explained only because all options are operated with the same method according to the option table.)

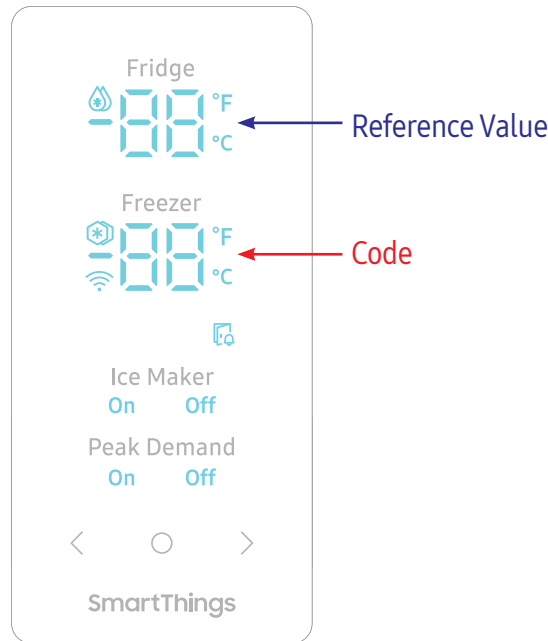

- 1) For example, if you want to change freezer compartment standard temperature to  $-4^{\circ}\text{F}(-2^{\circ}\text{C})$  by operating option, do as below. This function is for changing the standard temperature.  
In  $-2^{\circ}\text{F}(-19^{\circ}\text{C})$  of current temperature of freezer compartment, if you make the temperature lower to  $-4^{\circ}\text{F}(-2^{\circ}\text{C})$  by the option, the standard temperature would be controlled  $-6^{\circ}\text{F}(-21^{\circ}\text{C})$ .  
Therefore, if you change the setting of temperature option to  $-2^{\circ}\text{F}(-19^{\circ}\text{C})$  on the panel, the appliance will be operated with  $-6^{\circ}\text{F}(-21^{\circ}\text{C})$ . It means that standard temperature is controlled  $-4^{\circ}\text{F}(-2^{\circ}\text{C})$  less than setting temperature in the display.

### NOTE

Basically, all the data in option has cleared from the factory. Therefore, almost all setting value are "0". But, some setting values could be changed for the purpose of improving performance. NOTE You need to check the product manual and/or specification.

- 2) After changing to the option mode, fresh food compartment "0", freezer compartment "0" will be displayed. ( Basically fresh food compartment "0", freezer "0" would be set at shipping process, but setting value could be changed for the purpose of improving product at mass producing process.)
  - If fresh food compartment "0" shows only, temperature reference value of freezer compartment will be set and current freezer compartment temperature code will be displayed on the freezer temperature display.
- 3) If freezer compartment "4" is set as below freezer compartment code after fresh food compartment "0" is set, standard temperature of freezer compartment will be lower than  $-4^{\circ}\text{F}(-2.0^{\circ}\text{C})$ .  
(Refer to the picture "changing the freezer compartment temperature")

## CHECK THE INSTALLATION STATUS

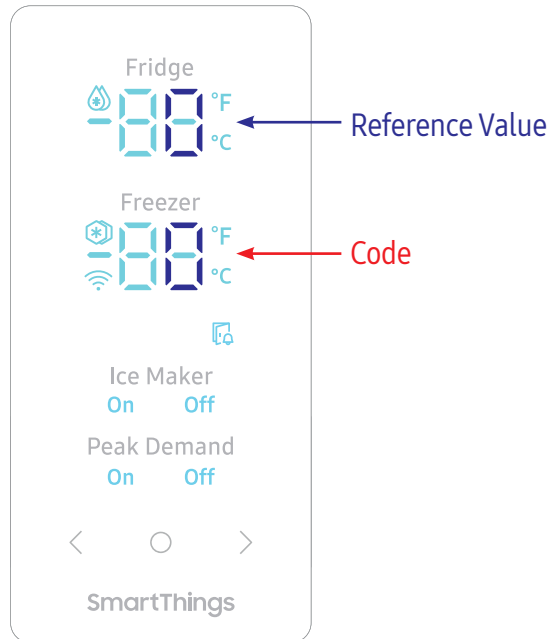

: If you wait for 20 seconds after completing the setting, MICOM will save the setting value to the EEPROM and normal display will be returned and the option setting mode will be canceled.

- 4) By the same method as above, it is possible to control the fresh food compartment temperature, water supply, ice-maker harvest temperature/time, defrost return time, hysteresis by temperature, notch gap by temperature etc.
- 5) Option function is set in the EEPROM at shipping process in the factory.  
You would better not to change the option of your own.  
Completing the setting is that option function return to normal display after 20 seconds.  
Do not turn off the appliance before returning to the normal display mode.

### NOTE

Option setting function exists in the other items. We will skip the explanation of the other functions by the option because it is associated with refrigerator control function and is not needed at SERVICE.

NOTE (Please do not set the other options except above SERVICE Manual.)

# CHECK THE INSTALLATION STATUS

## 5-1-7. Option TABLE

### 1) Temperature changing table of freezer compartment

Set item	Freezer Temp Shift
Reference Value	Fridge Room 7-SEG
Value	0
Setting value	Temp. compensation
FZ compartment Code	
0	0°F (0.0°C)
1	-1°F (-0.5°C)
2	-2°F (-1.0°C)
3	-3°F (-1.5°C)
4	-4°F (-2.0°C)
5	-5°F (-2.5°C)
6	-6°F (-3.0°C)
7	-7°F (-3.5°C)
8	+1°F (+0.5°C)
9	+2°F (+1.0°C)
10	+3°F (+1.5°C)
11	+4°F (+2.0°C)
12	+5°F (+2.5°C)
13	+6°F (+3.0°C)
14	+7°F (+3.5°C)
15	+8°F (+4.0°C)

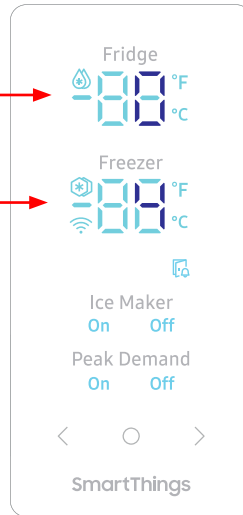

ex) If you want to change the freezer standard temperature to -4°F(-2°C).

### 2) Temperature changing table of fresh food compartment

Set item	fresh food Temp Shift
Reference Value	Fridge Room 7-SEG
Value	1
Setting value	Temp. compensation
FZ compartment Code	
0	0°F (0.0°C)
1	-1°F (-0.5°C)
2	-2°F (-1.0°C)
3	-3°F (-1.5°C)
4	-4°F (-2.0°C)
5	-5°F (-2.5°C)
6	-6°F (-3.0°C)
7	-7°F (-3.5°C)
8	+1°F (+0.5°C)
9	+2°F (+1.0°C)
10	+3°F (+1.5°C)
11	+4°F (+2.0°C)
12	+5°F (+2.5°C)
13	+6°F (+3.0°C)
14	+7°F (+3.5°C)
15	+8°F (+4.0°C)

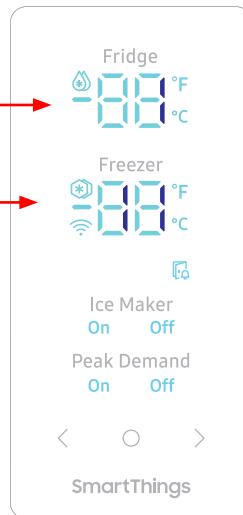

ex) If you want to change the fresh food compartment standard temperature to 4°F(2°C).

# CHECK THE INSTALLATION STATUS

### 3) Time changing table of Freezer ice maker dropping standby time

Set item	Ice Maker Dropping Standby Time
Reference Value	Fridge Room 7-Seg
	3

Setting value	Standby Time
Freezer Room 7-Seg(Code)	
0	58 min
1	57 min
2	56 min
3	55 min
4	54 min
5	53 min
6	52 min
7	51 min
8	50 min
9	49 min
10	48 min
11	47 min
12	46 min
13	45 min
14	59 min
15	60 min

### 4) Temperature changing table of Freezer Ice Maker dropping temperature

Set item	Ice Maker Dropping Temperature
Reference Value	Fridge Room 7-Seg
	4

Setting value	Dropping Temperature
Freezer Room 7-Seg (Code)	
0	-17°C
1	-16°C
2	-15°C
3	-14°C
4	-13°C
5	-12°C
6	-18°C
7	-19°C

# CHECK THE INSTALLATION STATUS

## 5) Operation rate changing table of dispenser heater

Set item	Dispenser Heater Rate
Reference Value	Fridge Room 7-SEG
	19

Setting value	Rate change
FZ compartment Code	
0	+0.0%
1	[Sub-Heater] + 20% operation( up to 100% ) [C-Fan] C-Fan turn on after 10 minutes delay when Comp On (It operates only external temperature 12°C ~39 °C )

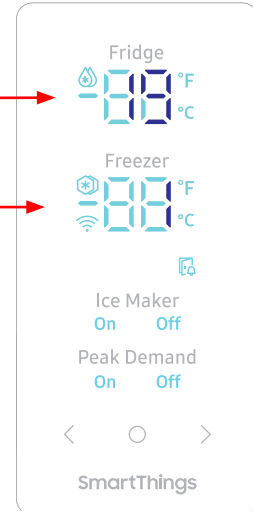

ex) If you want to change the dispenser heater operation rate to +20%.

## 6) Temperature changing table of freezer compartment (When the Freezer works as a Fridge Mode)

Set item	Freezer Temp Shift
Reference Value	Fridge Room 7-SEG
	31

Setting value	Temp. compensation
FZ Compartment code	
0	0.0°C
1	-0.5°C
2	-1.0°C
3	-1.5°C
4	+0.5°C
5	+1.0°C
6	+1.5°C
7	+2.0°C

# CHECK THE INSTALLATION STATUS

## 5-2) Diagnostic method according to the trouble symptom (Flow Chart)

### DATA1.Temperature table

Resistance value and MICOM port voltage of sensor according to the temperature  
 SENSOR CHIP : based on PX41C, PX41C, 502AT/103\*\*(ICE MAKER SENSOR(MOLD))/FULL UP, 20Kohm  
 ( Actual measurement = value of the table below X 2 )

°C	°F	Voltage	Resistance	°C	°F	Voltage	Resistance	°C	°F	Voltage	Resistance
-50	-58	4.694	153319	-5	23	3.107	16419	40	104	1.153	2997
-49	-56.2	4.677	144794	-4	24.8	3.057	15731	41	105.8	1.124	2899
-48	-54.4	4.659	136798	-3	26.6	3.006	15076	42	107.6	1.095	2805
-47	-52.6	4.641	129294	-2	28.4	2.955	14452	43	109.4	1.068	2714
-46	-50.8	4.622	122248	-1	30.2	2.904	13857	44	111.2	1.040	2627
-45	-49	4.602	115631	0	32	2.853	13290	45	113	1.014	2543
-44	-47.2	4.581	109413	1	33.8	2.802	12749	46	114.8	0.988	2462
-43	-45.4	4.560	103569	2	35.6	2.751	12233	47	116.6	0.963	2384
-42	-43.6	4.537	98073	3	37.4	2.700	11741	48	118.4	0.938	2309
-41	-41.8	4.514	92903	4	39.2	2.649	11271	49	120.2	0.914	2237
-40	-40	4.490	88037	5	41	2.599	10823	50	122	0.891	2167
-39	-38.2	4.465	83456	6	42.8	2.548	10395	51	123.8	0.868	2100
-38	-36.4	4.439	79142	7	44.6	2.498	9986	52	125.6	0.846	2036
-37	-34.6	4.412	75077	8	46.4	2.449	9596	53	127.4	0.824	1973
-36	-32.8	4.385	71246	9	48.2	2.399	9223	54	129.2	0.803	1913
-35	-31	4.356	67634	10	50	2.350	8867	55	131	0.783	1855
-34	-29.2	4.326	64227	11	51.8	2.301	8526	56	132.8	0.762	1799
-33	-27.4	4.296	61012	12	53.6	2.253	8200	57	134.6	0.743	1745
-32	-25.6	4.264	57977	13	55.4	2.205	7888	58	136.4	0.724	1693
-31	-23.8	4.232	55112	14	57.2	2.158	7590	59	138.2	0.706	1642
-30	-22	4.199	52406	15	59	2.111	7305	60	140	0.688	1594
-29	-20.2	4.165	49848	16	60.8	2.064	7032	61	141.8	0.670	1547
-28	-18.4	4.129	47431	17	62.6	2.019	6771	62	143.6	0.653	1502
-27	-16.6	4.093	45146	18	64.4	1.974	6521	63	145.4	0.636	1458
-26	-14.8	4.056	42984	19	66.2	1.929	6281	64	147.2	0.620	1416
-25	-13	4.018	40938	20	68	1.885	6052	65	149	0.604	1375
-24	-11.2	3.980	39002	21	69.8	1.842	5832	66	150.8	0.589	1335
-23	-9.4	3.940	37169	22	71.6	1.799	5621	67	152.6	0.574	1297
-22	-7.6	3.899	35433	23	73.4	1.757	5419	68	154.4	0.560	1260
-21	-5.8	3.858	33788	24	75.2	1.716	5225	69	156.2	0.546	1225
-20	-4	3.816	32230	25	77	1.675	5039	70	158	0.532	1190
-19	-2.2	3.773	30752	26	78.8	1.636	4861	71	159.8	0.519	1157
-18	-0.4	3.729	29350	27	80.6	1.596	4690	72	161.6	0.506	1125
-17	1.4	3.685	28021	28	82.4	1.558	4526	73	163.4	0.493	1093
-16	3.2	3.640	26760	29	84.2	1.520	4369	74	165.2	0.481	1063
-15	5	3.594	25562	30	86	1.483	4218	75	167	0.469	1034
-14	6.8	3.548	24425	31	87.8	1.447	4072	76	168.8	0.457	1006
-13	8.6	3.501	23345	32	89.6	1.412	3933	77	170.6	0.446	978
-12	10.4	3.453	22320	33	91.4	1.377	3799	78	172.4	0.435	952
-11	12.2	3.405	21345	34	93.2	1.343	3670	79	174.2	0.424	926
-10	14	3.356	20418	35	95	1.309	3547	80	176	0.414	902
-9	15.8	3.307	19537	36	96.8	1.277	3428	81	177.8	0.404	877
-8	17.6	3.258	18698	37	98.6	1.253	3344	82	179.6	0.394	854
-7	19.4	3.208	17901	38	100.4	1.213	3204	83	181.4	0.384	832
-6	21.2	3.158	1714	39	102.2	1.183	3098	84	183.2	0.375	810

## CHECK THE INSTALLATION STATUS

### DATA2. Humidity Sensortable

- Voltage output table @23°..., 5Vdc --- HTG3515CH/HTG3535CH

RH(Temperature compensate) = RH (Relative Humidity) + (Temp(°C) - 23 °C) x 0.05

RH(%)	Output(mV)	A/D (10bit)	A/D (12bit)	RH(%)	Output(mV)	A/D (10bit)	A/D (12bit)	RH(%)	Output(mV)	A/D (10bit)	A/D (12bit)
0	909	186	744	46	2246	460	1839	92	3452	706	2827
1	943	193	772	47	2272	465	1861	93	3478	712	2848
2	977	200	800	48	2298	470	1882	94	3504	717	2870
3	1010	207	827	49	2324	475	1903	95	3530	722	2891
4	1043	213	854	50	2350	481	1925	96	3566	730	2920
5	1076	220	881	51	2376	486	1946	97	3595	735	2944
6	1109	227	908	52	2402	491	1967	98	3624	741	2968
7	1141	233	935	53	2428	497	1989	99	3653	747	2992
8	1173	240	961	54	2454	502	2010	100	3683	754	3016
9	1205	247	987	55	2480	507	2031				
10	1235	253	1011	56	2505	513	2052				
11	1266	259	1037	57	2530	518	2072				
12	1297	265	1062	58	2555	523	2093				
13	1328	272	1088	59	2580	528	2113				
14	1359	278	1113	60	2605	533	2133				
15	1390	284	1138	61	2630	538	2154				
16	1420	291	1163	62	2655	543	2174				
17	1450	297	1188	63	2680	548	2195				
18	1480	303	1212	64	2705	553	2215				
19	1510	309	1237	65	2730	559	2236				
20	1540	315	1261	66	2756	564	2257				
21	1569	321	1285	67	2782	569	2278				
22	1598	327	1309	68	2808	575	2300				
23	1627	333	1333	69	2834	580	2321				
24	1656	339	1356	70	2860	585	2342				
25	1685	345	1380	71	2886	590	2364				
26	1713	350	1403	72	2912	596	2385				
27	1741	356	1426	73	2938	601	2406				
28	1769	362	1449	74	2964	606	2428				
29	1797	368	1472	75	2990	612	2449				
30	1825	373	1495	76	3017	617	2471				
31	1852	379	1517	77	3044	623	2493				
32	1879	384	1539	78	3071	628	2515				
33	1906	390	1561	79	3098	634	2537				
34	1933	395	1583	80	3125	639	2559				
35	1960	401	1605	81	3152	645	2581				
36	1986	406	1627	82	3179	650	2604				
37	2012	412	1648	83	3206	656	2626				
38	2038	417	1669	84	3233	661	2648				
39	2064	422	1690	85	3260	667	2670				
40	2090	428	1712	86	3288	673	2693				
41	2116	433	1733	87	3316	678	2716				
42	2142	438	1754	88	3344	684	2739				
43	2168	444	1776	89	3372	690	2762				
44	2194	449	1797	90	3400	696	2785				
45	2220	454	1818	91	3426	701	2806				

## 6. SELF DIAGNOSIS & TROUBLE SHOOTING

### 6-1) If the trouble is detected by self-diagnosis

- The error of sensor will be displayed on the front of display. when the error of sensor is detected at initial power ON, the appliance will not operated and display of abnormal sensor part will blink.
- The appliance will not stop operating when the error of sensor is detected during operation of the appliance. But normal freezing might be not operated if the appliance is operated by the emergency operation mode. You would better to check the appliance according to the self-diagnosis of the manual.

#### 1) If ICE Maker Sensor has troubled (check the other sensors in the same procedure)

##### ERROR Code

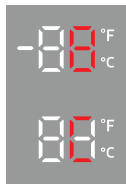

##### DATA1. Temperature table

\*\* Measuring point of resistance value according to Sensor  
 \*\* ICE MAKER : CN30 "9" ↔ "11" measuring resistance value  
 \*\* 0Ω: Short trouble / ∞Ω: Open trouble

Refer to circuit diagram in the manual

##### Sensor MICOM/Connector number

ICE MAKER : (F) CN30 "9"(WHT) ↔ "11"(WHT) measuring resistance value

Voltage measured between 4.6V ~ 0.6V.

##### ICE Maker:

Measuring voltage of IC01 MICOM #12, CN30-"9"(WHT) and "11" Pin(CN30) from PCB typical Ground part are similar.  
 → Check the measure on the voltage of Resistance, R905 DUE to the SMD MICOM.

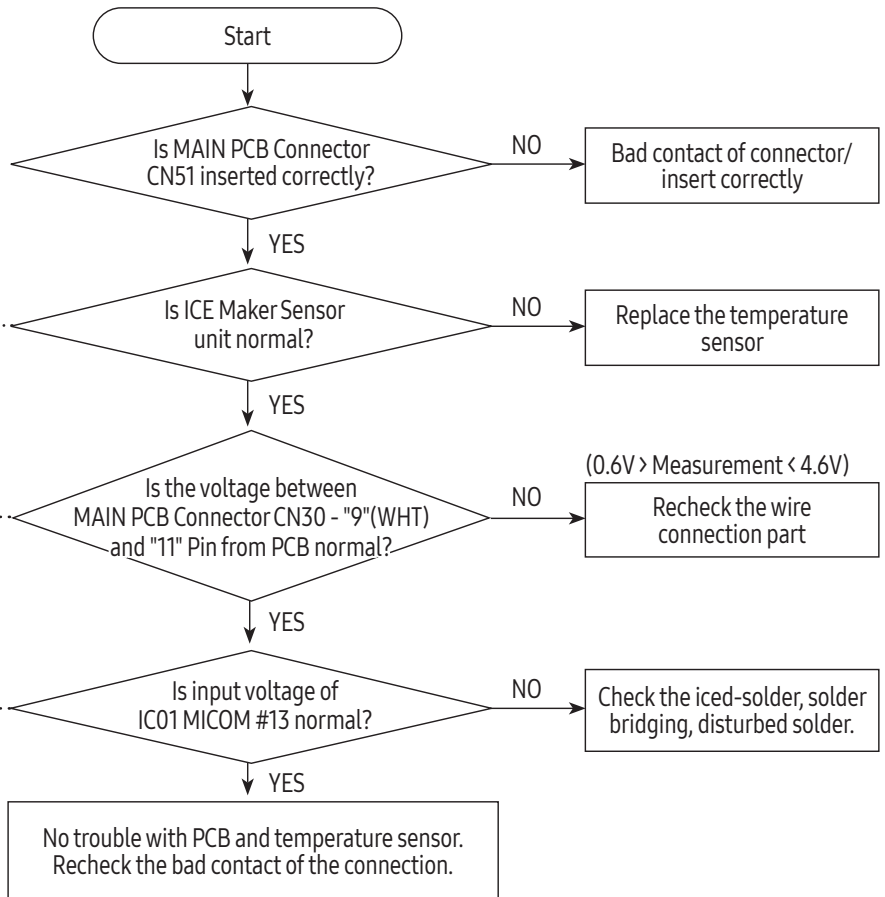

##### ICE Maker

☞ Checking method of ICE Maker Sensor resistance

CN30 "9"(FLAT WHT) ↔ "11"(FLAT WHT) - Compare the temperature table after the measure.



##### PIN Number

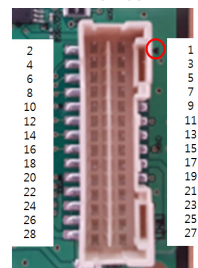

##### ☞ Checking method of ICE Maker Sensor resistance

- Measure the voltage of Resistance

ICE Maker : R905(IC01 MICOM #12) on PCB or CN30 "9"(WHT) and "11" Pin(CN90) from PCB

- Compare the temperature table after the measure.

Measuring voltage of ICE Maker : CN30 "9"(WHT) and "11" Pin(CN90) from PCB.

# CHECK THE INSTALLATION STATUS

## 2) If R Sensor has trouble (check the other sensors in the same procedure)

### ERROR Code

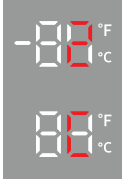

#### DATA1. Temperature table

\*\* Measuring point of resistance value according to Sensor  
 R : CN51 - "14" ↔ "13"  
 F : CN51 - "9" ↔ "11"  
 R-DEF : CN51 - "12" ↔ "13"  
 F-DEF : CN51 - "5" ↔ "7"  
 Ambient : CN51 - "4" ↔ CN51 - "6"  
 measuring resistance value  
 \*\* 0Ω: Short trouble /∞Ω: Open trouble

Refer to circuit diagram in the manual

#### Sensor MICOM/Connector number

R : Connector CN51 - "14"(W/BRN) and "13" Pin(CN51) from PCB typical Ground  
 F : Connector CN51 - "9"(BLU) and "11" Pin(CN51) from PCB typical Ground  
 R-DEF : Connector CN20 - "12"(W/BLU) and "13" Pin(CN51) from PCB typical Ground  
 F-DEF : Connector CN51 - "5"(BLK) and "7" Pin(CN51) from PCB typical Ground  
 Ambient : Connector CN51 - "6"(WHT) and CN51 - "4" Pin(CN51) from PCB typical Ground

Voltage measured between 4.6V ~ 0.6V.

Checking method of ICE Maker/ICE Room Sensor resistance  
 Measuring voltage.

R : MIC01 MICOM #8, CN51 - "14"(W/BRN) and "13" Pin(CN51)  
 F : MIC01 MICOM #2, CN51 - "9"(BLU) and "11" Pin(CN51)  
 R-DEF : MIC01 MICOM #4, CN51 - "12"(W/BLU) and "13" Pin(CN51)  
 F-DEF : MIC01 MICOM #3, CN51 - "5"(BLK) and "7" Pin(CN51)  
 Ambient : MIC01 MICOM #2, CN51 - "6"(WHT) and CN51 - "4" Pin(CN51) from PCB typical Ground part are similar.

→ Check the measure on the voltage of Resistance, R364(R), R356(F), R362(R-DEF), R352(F-DEF), R358(Ambient) due to the SMD MICOM

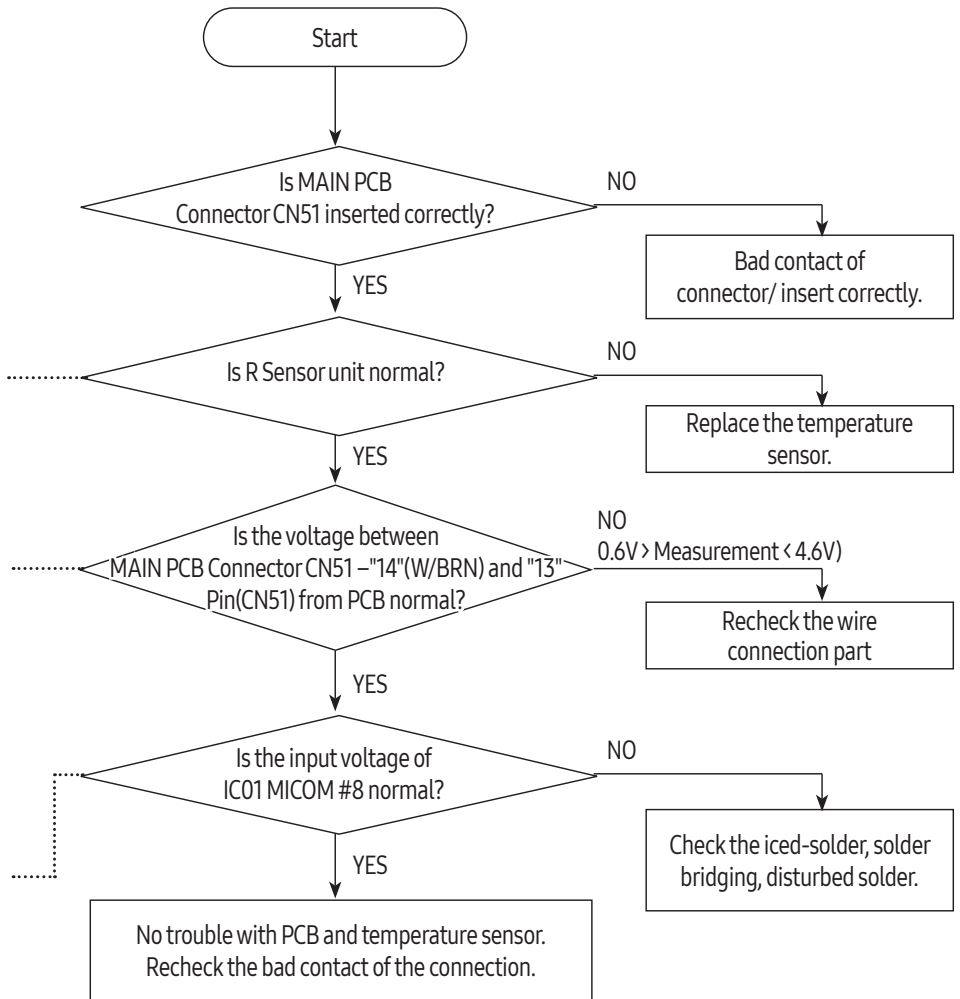

#### Checking method of R Sensor resistance

R : CN51 - "14"(W/BRN) ↔ "13"(GRY)  
 F : CN51 - "9"(BLU) ↔ "11"(WHT)  
 R-DEF : CN51 - "12"(W/BLU) ↔ "13"(GRY)  
 F-DEF : CN51 - "5"(BLK) ↔ "7"(WHT)  
 Ambient : CN51 - "4"(WHT) ↔ CN90 - "6"(WHT)  
 Compare the temperature table after measurement.



#### Checking method of Sensor resistance

- Measure the voltage of Resistance  
 R : R364(IC01 MICOM #8) on PCB or CN51 - "14"(W/BRN) and "13" Pin(CN51) from PCB  
 F : R356(IC01 MICOM #2) on PCB or CN51 - "9"(BLU) and "11" Pin(CN51) from PCB  
 R-DEF : R362(IC01 MICOM #4) on PCB or CN51 - "12"(W/BLU) and "13" Pin(CN51) from PCB.  
 F-DEF : R352(IC01 MICOM #3) on PCB or CN51 - "5"(BLK) and "7" Pin(CN51) from PCB  
 Ambient : R358(IC01 MICOM #2) on PCB or CN51 - "6"(WHT) and CN51 - "4" Pin(CN51) from PCB  
 - Compare the temperature table after the measure.  
 Measuring voltage of  
 R : R364(IC01 MICOM #8) on PCB or CN51 - "14"(W/BRN) and "13" Pin(CN51)  
 F : R356(IC01 MICOM #2) on PCB or CN51 - "9"(BLU) and "11" Pin(CN51)  
 R-DEF : R362(IC01 MICOM #4) on PCB or CN51 - "12"(W/BLU) and "13" Pin(CN51)  
 F-DEF : R352(IC01 MICOM #3) on PCB or CN51 - "5"(BLK) and "7" Pin(CN51)  
 Ambient : R358(IC01 MICOM #2) on PCB or CN51 - "6"(WHT) and CN51 - "4" Pin(CN51) from PCB are as below.

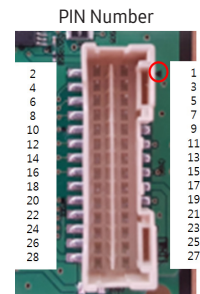

# CHECK THE INSTALLATION STATUS

## 3) If Humidity Sensor has trouble

### ERROR Code

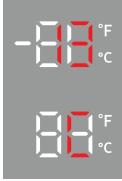

DATA1. Temperature table	
** Measuring point of resistance value according to Sensor Humidity: CN51 - "4" ↔ CN51 - "8"	
Resistance value with opened : about 50Ω	
** 0Ω: Short trouble / ∞Ω: Open trouble	
Refer to circuit diagram in the manual	

Sensor MICOM/Connector number	
Humidity	Connector CN51 - "4"(WHT) and CN51 - "8" Pin from PCB typical Ground.
Voltage measured between 3.5V ~ 1.0V.	

Measuring voltage of IC01 MICOM #8, CN51 - "4"(WHT) and CN51 - "8" Pin from PCB typical Ground part are similar.  
→ Check the voltage of Resistance, R366.

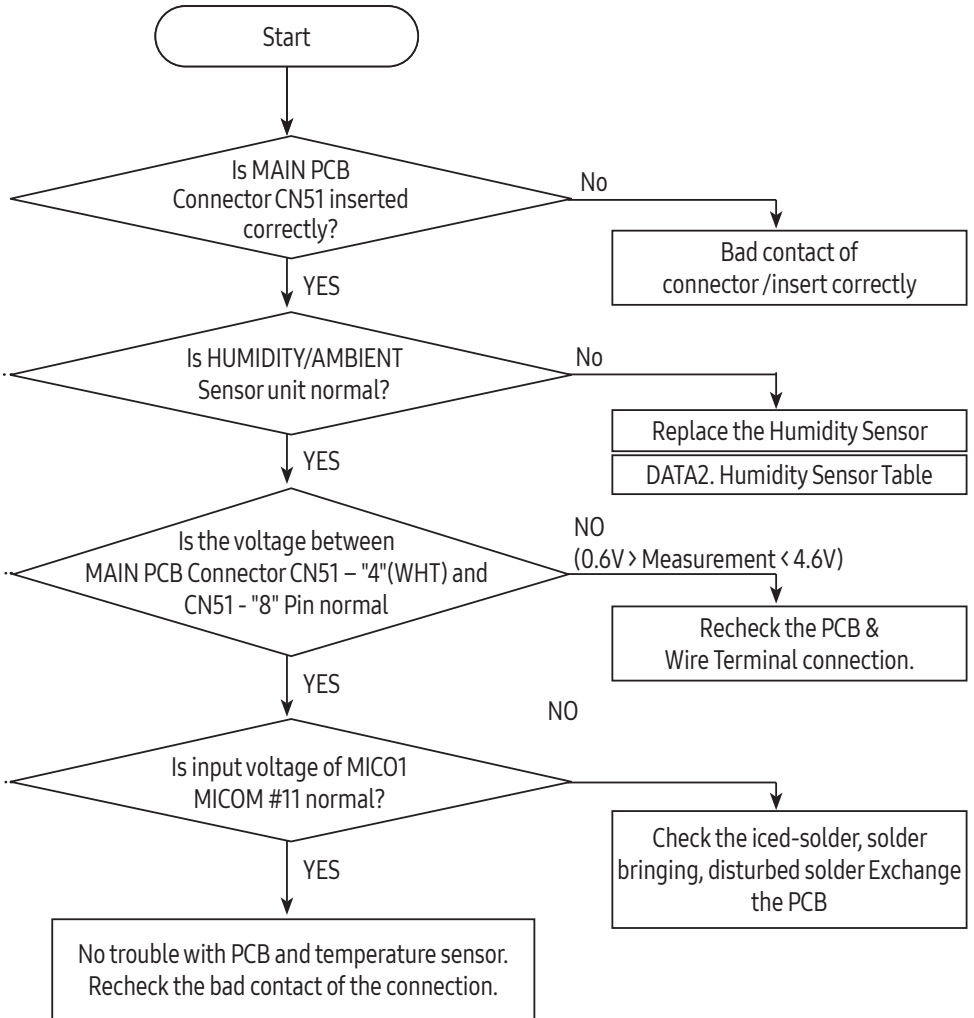

☞ Checking method of Humidity Sensor resistance  
CN51 - "4"(FLAT\_WHT) ↔ CN51 - "8"(FLAT\_WHT)  
- Compare the temperature table after the measure.

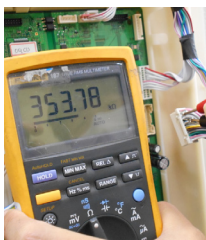

☞ Checking method of Sensor resistance  
- Measure the voltage of Resistance, R366(MICO1 MICOM #11) on PCB or CN51 - "4"(WHT) and CN51 - "8" Pin from PCB are as below.  
- Compare the temperature table after the measure.  
Measuring voltage of R366(MICO1 MICOM #11) on PCB or CN51 - "4"(WHT) and CN51 - "8" Pin from PCB are as below.

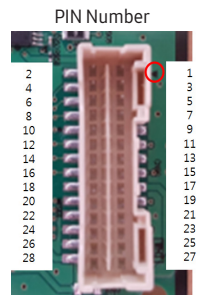

# CHECK THE INSTALLATION STATUS

## 6-2) IF FAN does not operate

- The refrigerator of this model has BLDC FAN motor. BLDC motor is driven by DC 7~12V.
- On the normal condition of COMP ON, it operates together with F-FAN motor. If door is opened and closed once at a high ambient temperature, it will be operated after 1 minute delay. Therefore, you are advised not to taken it for an error.
- If there is a trouble, you should select the self-diagnostic function to check the trouble before power off.

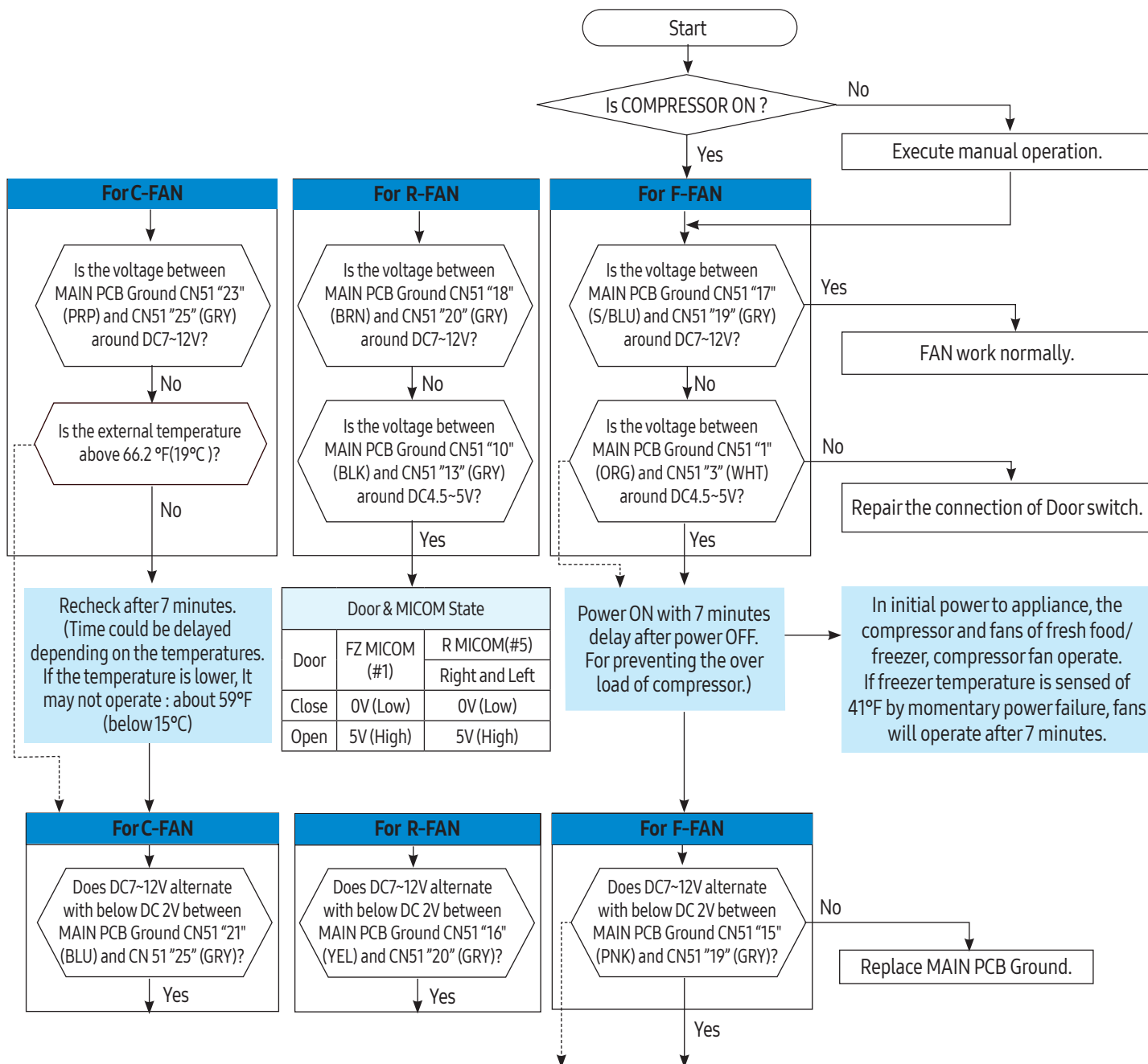

◆ Expected causes

- ① Check that if FAN-MOTOR has failure itself.
- ② Check that if wiring connection has bad contact.
- ③ Check the input of the fan motor rotation pulse when motor fan operates.

# CHECK THE INSTALLATION STATUS

## IF FAN does not operate

### F FAN pulse voltage CN51 "15"(PNK)



The voltage measured around 2~3V with multi-meter though the voltage is very weak because of pulse signal.

### Reference

CN51-15(F),CN51-16(R),CN51-21(C) will generate the pulse signal when motor rotates. These signals will be inputted into MICOM.

Unless signals are not inputted during motor operating, will be ON 10 seconds after fan Off. But if signals are not still entered, the above operation will restart four times more.

If signals are not entered continuously, the motor will be restarted after 10 Minutes. This function is effective when the normal operation of motor would be restrained by foreign matters such as ice.

### Display for checking the self-diagnostic function

#### F FAN ERROR

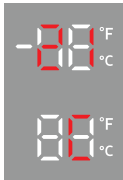

#### C FAN ERROR

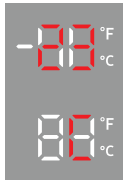

#### R FAN ERROR

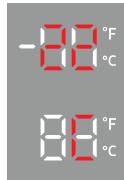

The voltage between PCB typical Ground CN51 "13" Pin and F FAN : CN51 "17" (S/BLU) shall be less than DC 7~12V.  
R FAN : CN51 "18" (BRN) shall be less than DC 7~12V.  
C FAN : CN 51 "23" (PRP) shall be less than DC 7~12V.

- Recheck if resistance values are different after measuring.

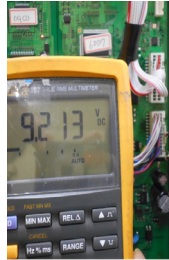

PIN Number

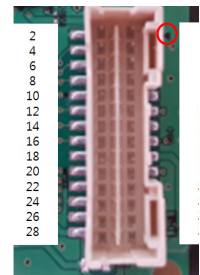

# CHECK THE INSTALLATION STATUS

## 6-3) When ICE MAKER(FZ) does not operate (OPTION)

1. Water will be automatically supplied to the Ice Maker depending on temperature & time conditions, and ice will be produced to dispense.
2. Power is applied to one end of the wires. So, make sure to refer to its Exploded View whenever doing the disassembly.
3. The operation of the Ice Maker shall be done after pressing the Ice Maker Test Button. (Freezer Ice Maker) It is not possible to check when the power is off.
4. Since both of the PCB and the Ice Maker are located at the front and the back each other, make sure to have two people check them.

### ERROR Code

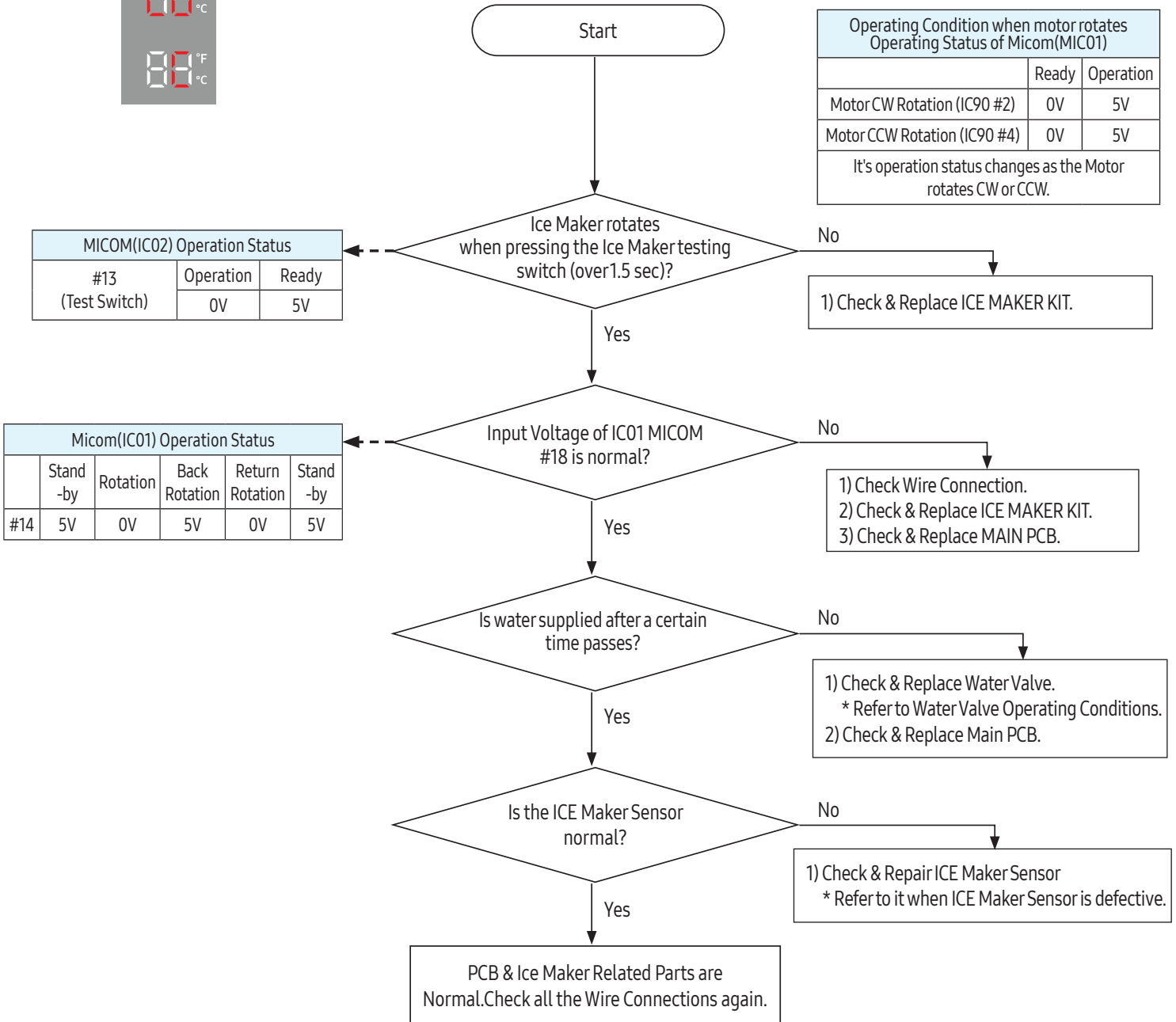
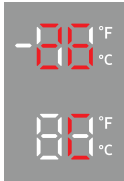

# CHECK THE INSTALLATION STATUS

## 6-4) If defrost does not operate (F/R DEF Heater)

- If defrost has trouble, select the self-diagnostic function to detect the error of defrost heater before Power Off. (Check the function with the self-diagnostic function.)

### F DEF ERROR    R DEF ERROR

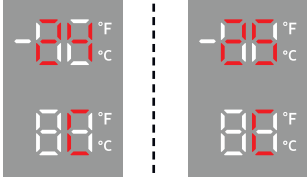

**\*\* Measuring point of resistance value according to heater\*\***  
 R-DEF : CN70 "5"(WHT) ↔ CN70 "1" (BLK) measuring resistance value(132 ohm ± 7%)  
 F-DEF : CN70 "3"(BLU) ↔ CN70 "1" (BLK) measuring resistance value(63 ohm + 8%)  
**\*\* 0Ω: Short trouble / ∞Ω: Open(bimetal, heater) trouble**

Reference to the manual "Self-Diagnostic".

**\*\* Measuring point of resistance value according to sensor\*\***  
 R-DEF : CN51 - "12" ↔ "13" measuring resistance value  
 F-DEF : CN51 - "5" ↔ "7" measuring resistance value  
**\*\* 0Ω : Short trouble / ∞Ω : Open trouble**

Resistance value of sensor according to temperature	
86°F(30°C)	4.22kΩ
68°F(20°C)	6.05kΩ
50°F(10°C)	8.87kΩ
32°F(0°C)	13.29kΩ
14°C (-10°F)	20.42kΩ
-4°F(-20°C)	32.23kΩ
-22°F(-30°C)	52.41kΩ

If you need the temperature with detail, refer to DATA1. temperature table

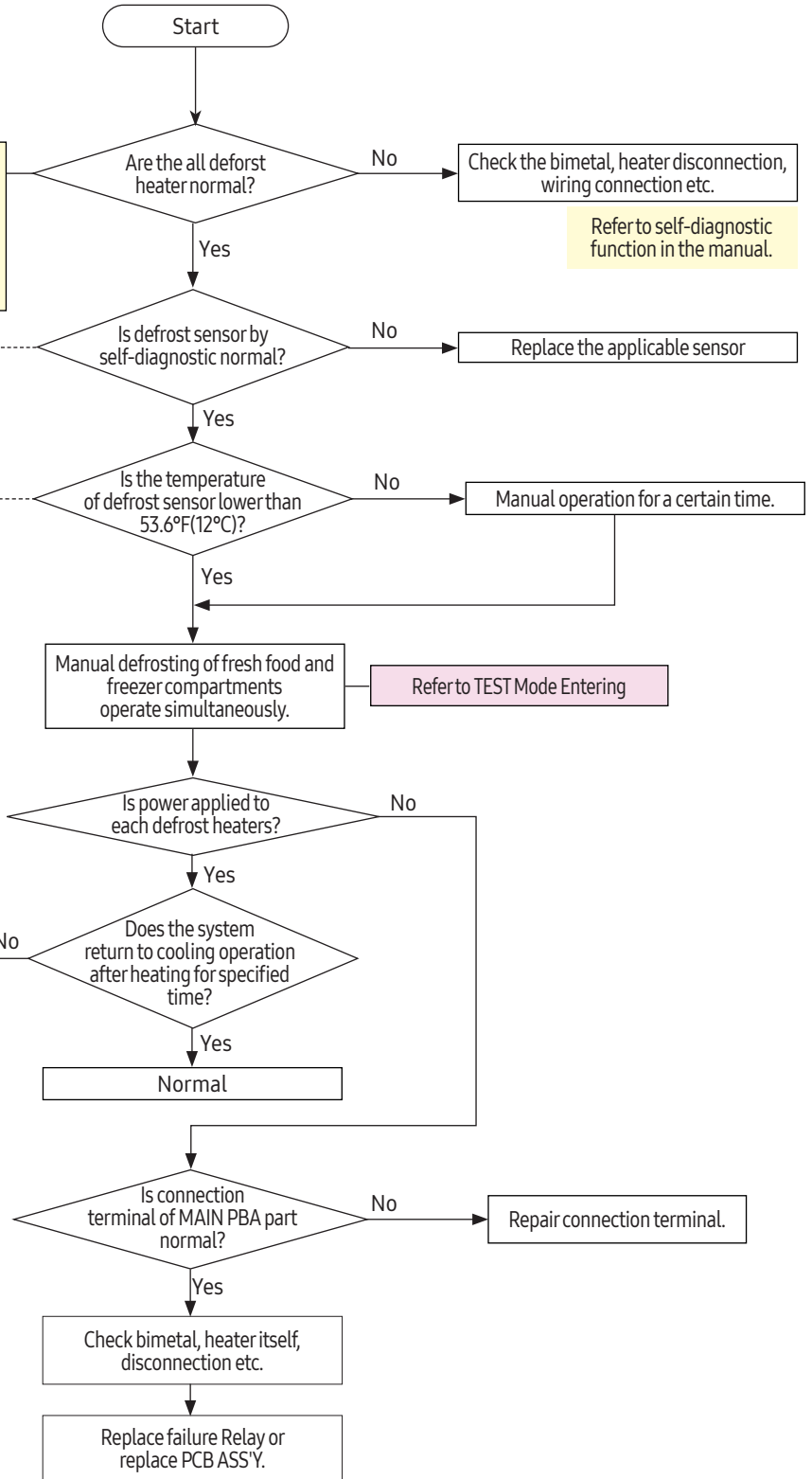

### Checking method of F DEF Heater resistance value

F-DEF : CN70 "3"(BLU) ↔ CN70 "1" (BLK)  
 R-DEF : CN70 "5"(WHT) ↔ CN70 "1" (BLK)  
 - Recheck if resistance values are different after the test

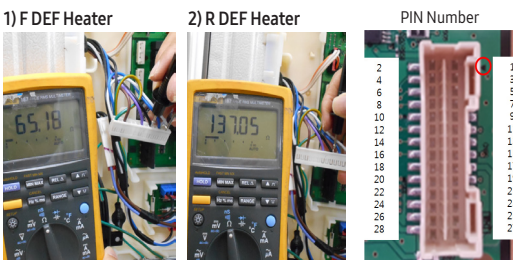

## CHECK THE INSTALLATION STATUS

### 6-5) When Power is not applied

#### Caution

At the power of SMPS PCB, the AC115(230)V power and a high-voltage over DC 170(325)V are occurred. Please take care of yourself on repair and measurement.

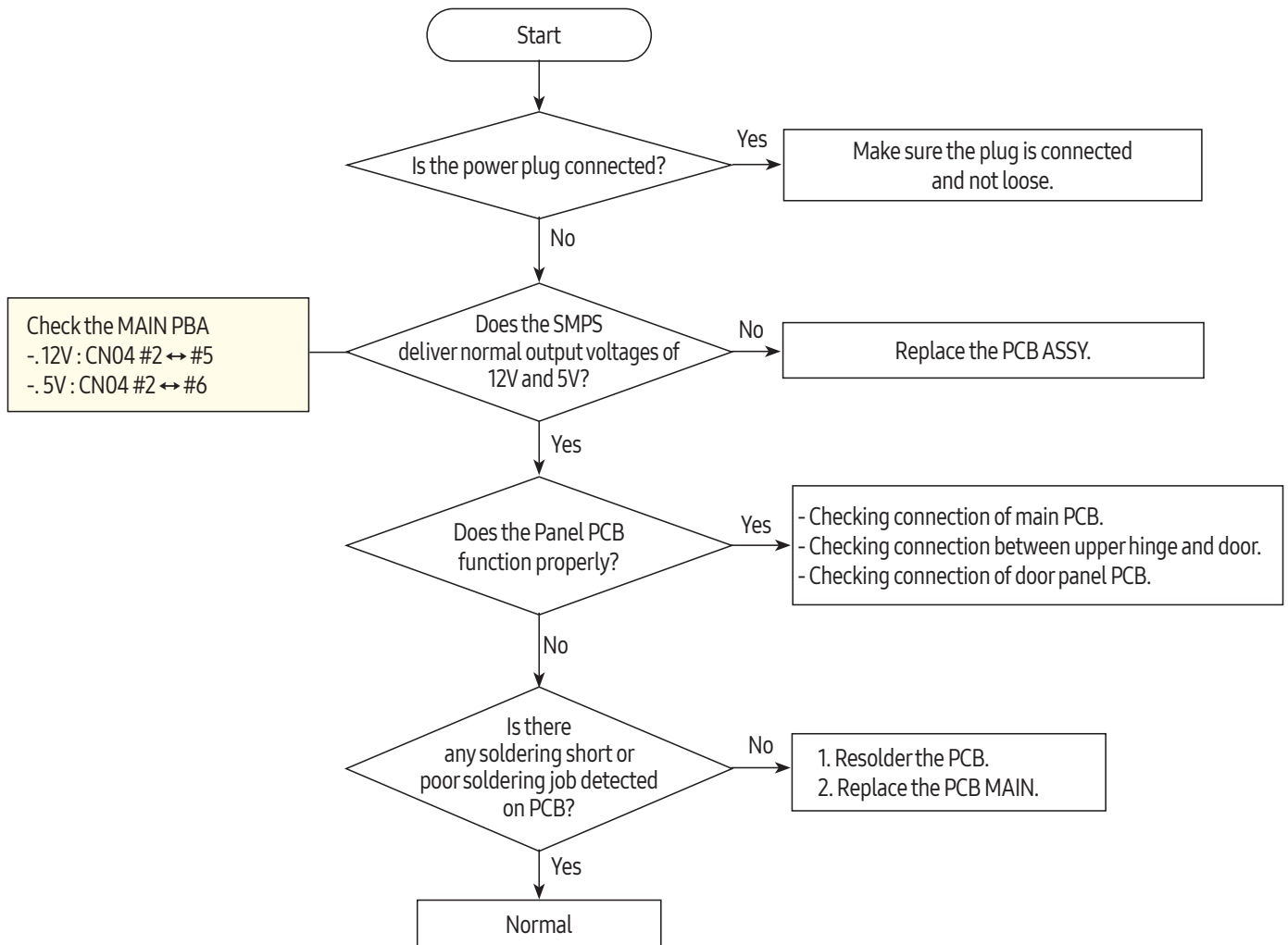

# CHECK THE INSTALLATION STATUS

## 6-6) When Compressor does not run (Inverter COMP.)

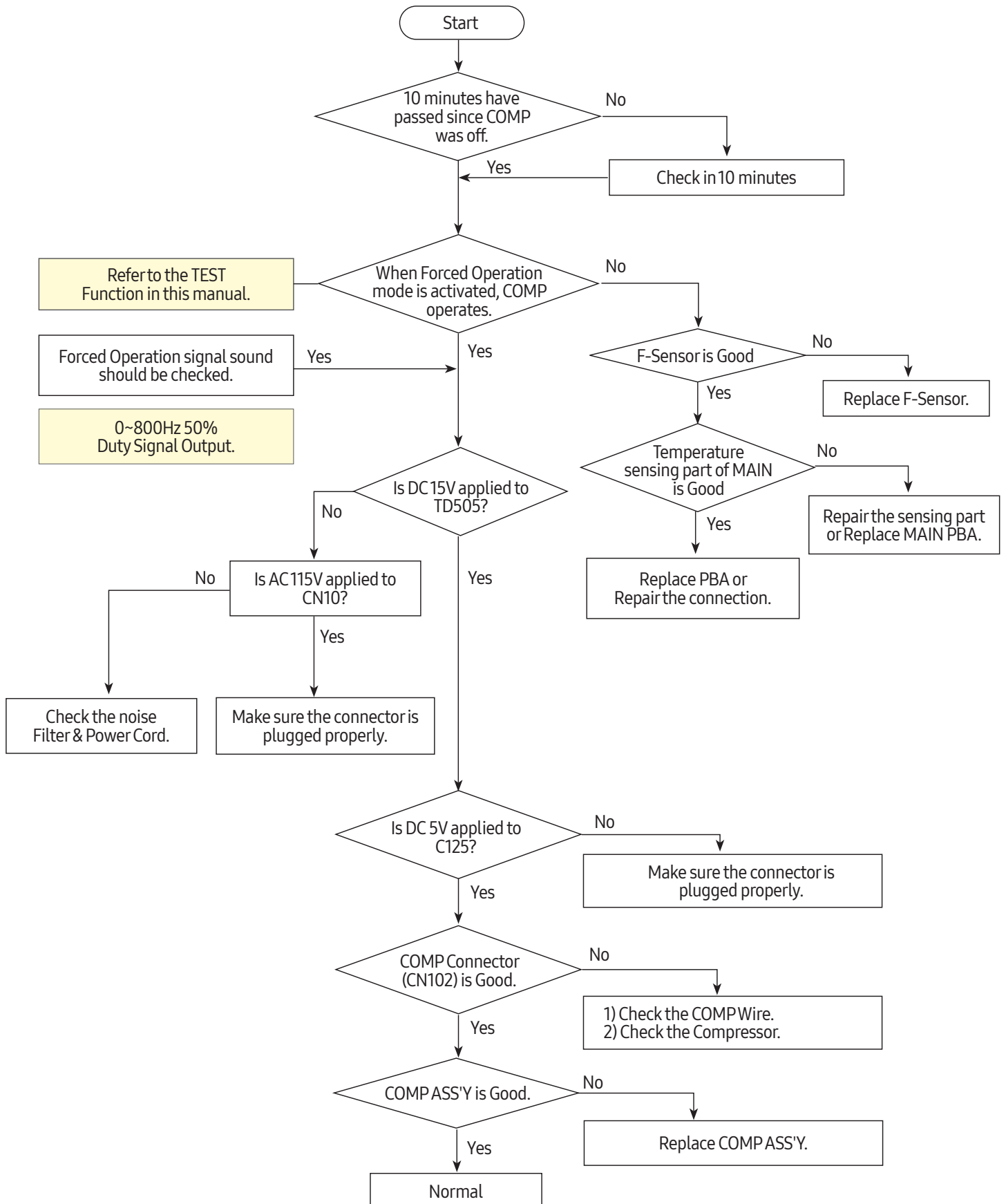

# CHECK THE INSTALLATION STATUS

## 6-7) When alarm sounds continuously without stop (related with buzzer sound)

### ① If 'diring-diring' sound continuously

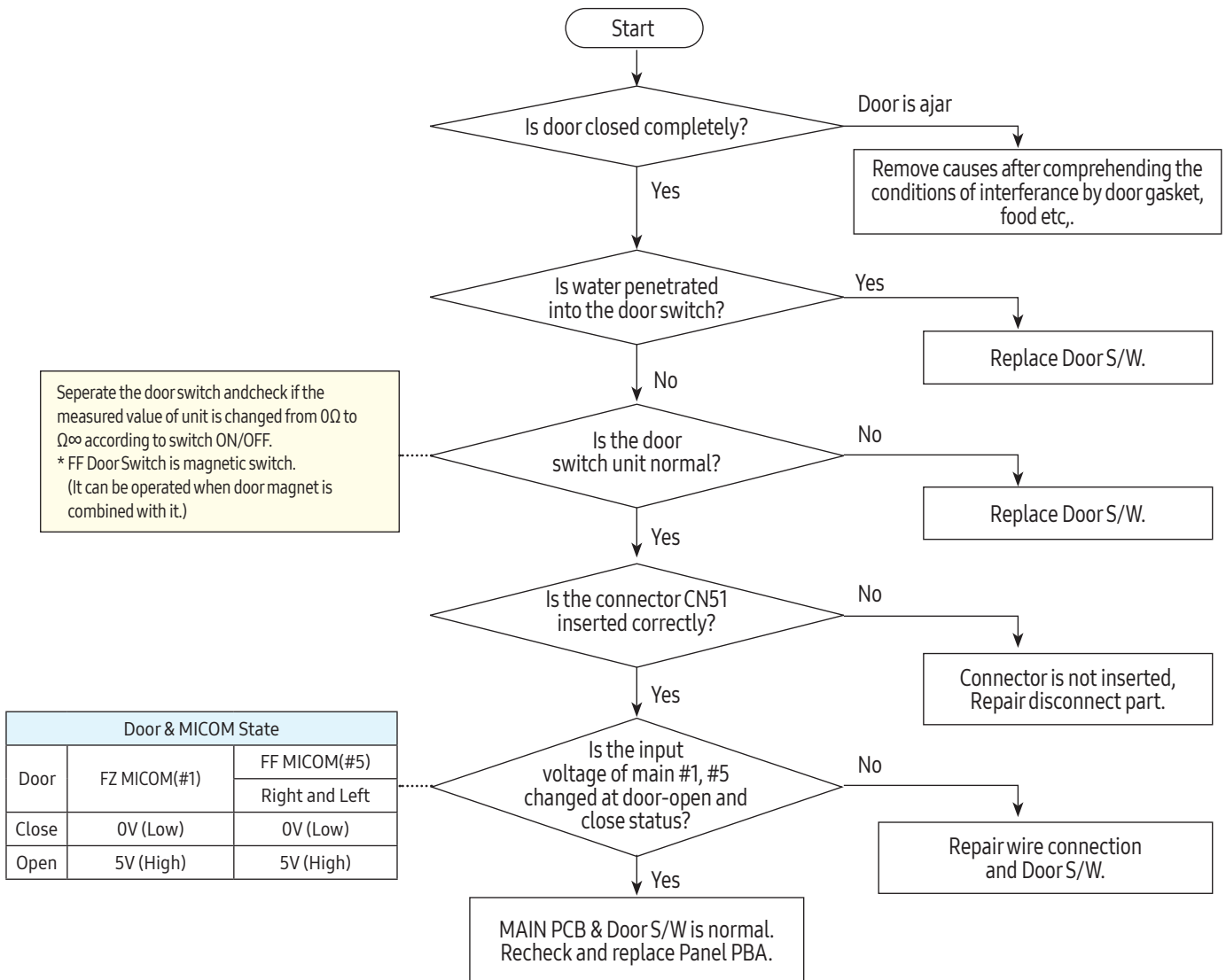

### ② If 'beep-beep' sounds continuously

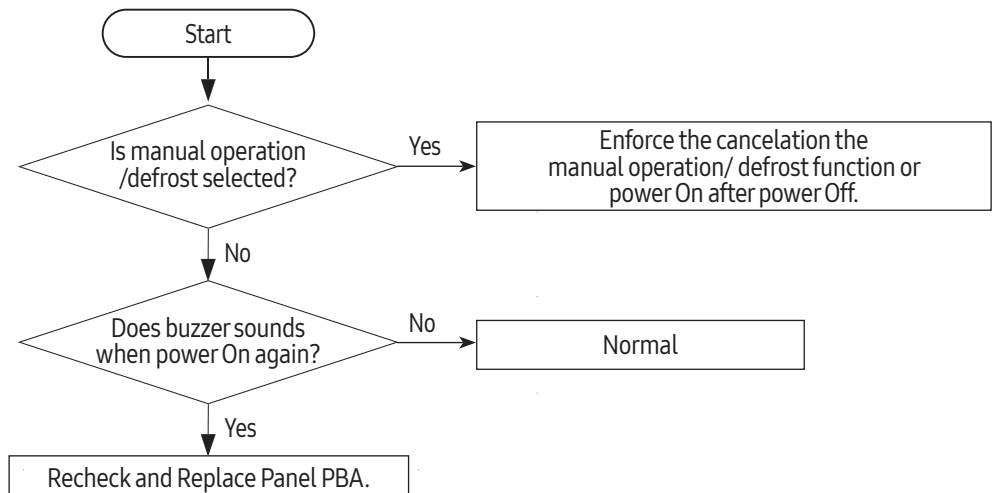

## CHECK THE INSTALLATION STATUS

### When alarm sounds continuously without stop (related with buzzer sound)

#### ③ If buzzer does not sound

Buzzer is installed on the Assy Top Table in this model.

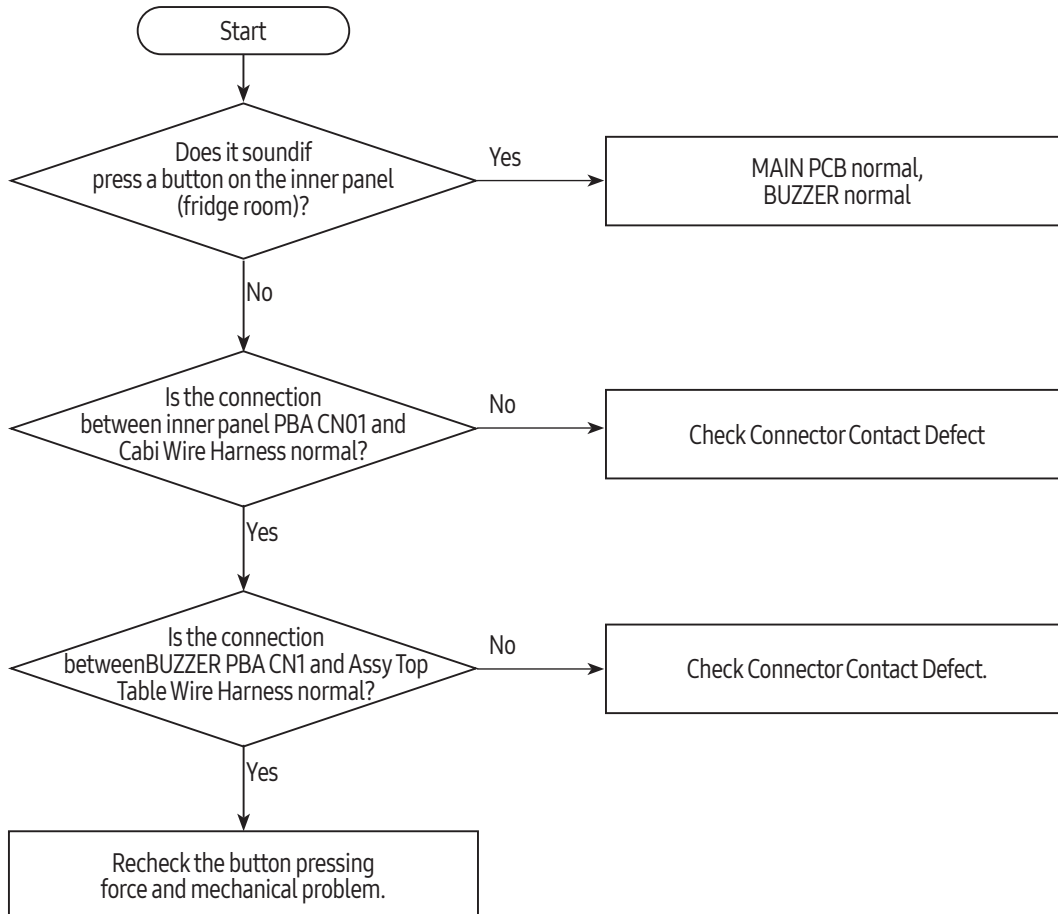

# CHECK THE INSTALLATION STATUS

## 6-8) When the Inner Panel PBA does not operate normally

### ① When the entire or a certain section of the Panel PCB does not light up

- There is a MICOM embedded in the Panel PCB. So, take care when doing repairs.  
And, except the Solder Touch, replace the PCB.

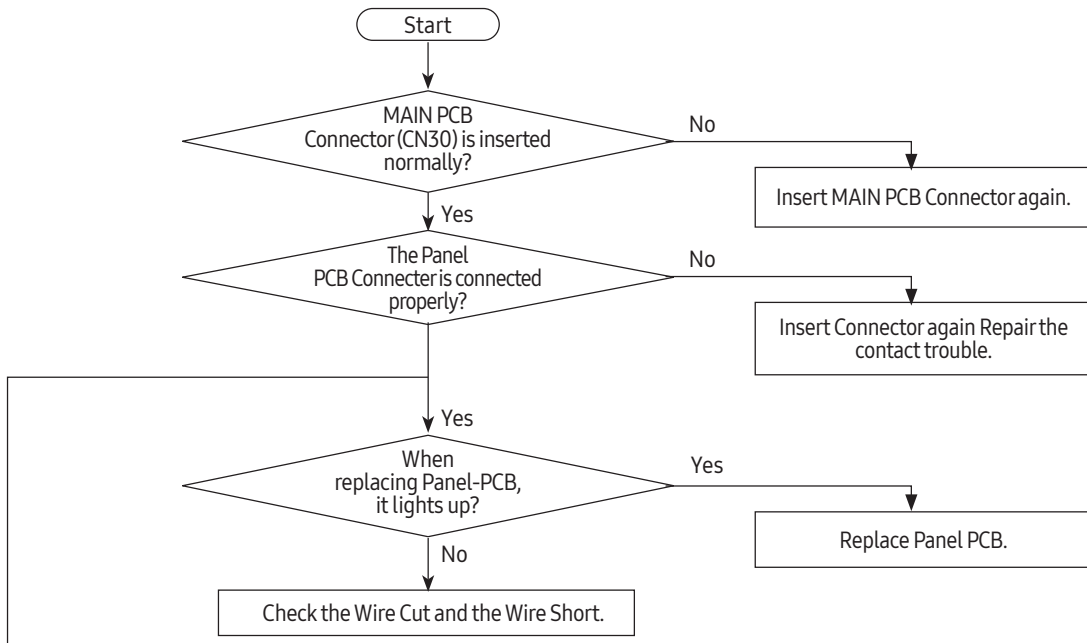

### ② When the Panel PCB buttons do not work

※ When it keeps troubling after check with the above procedures.  
[Check after turning off the unit and turning it on again.]

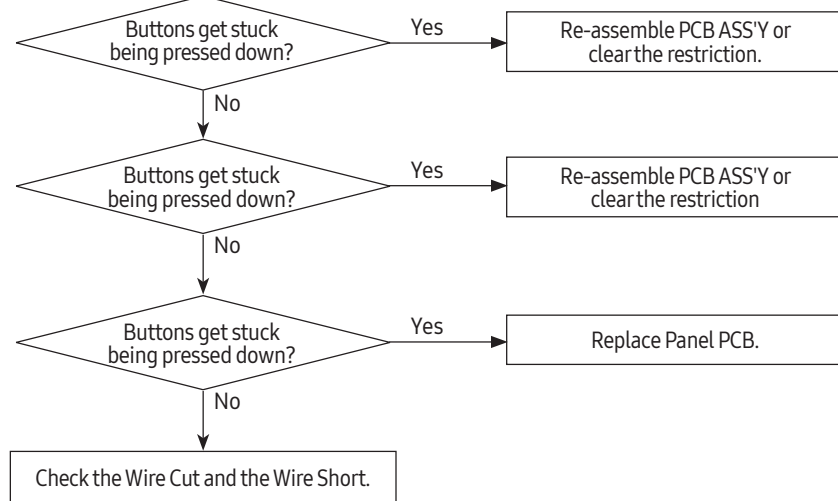

# CHECK THE INSTALLATION STATUS

## 6-9) When refrigerator ROOM Lamp does not light up

When controlling the refrigerator light with Regulator(12V) : LED LAMP  
 → Applying to the F/R Room compartment (Option)

\* If the Vegetable Lamp does not work properly, check the R compartment LED Lamp because it is connected with the R compartment LED Lamp in parallel. Refer to the circuit diagram to repair.

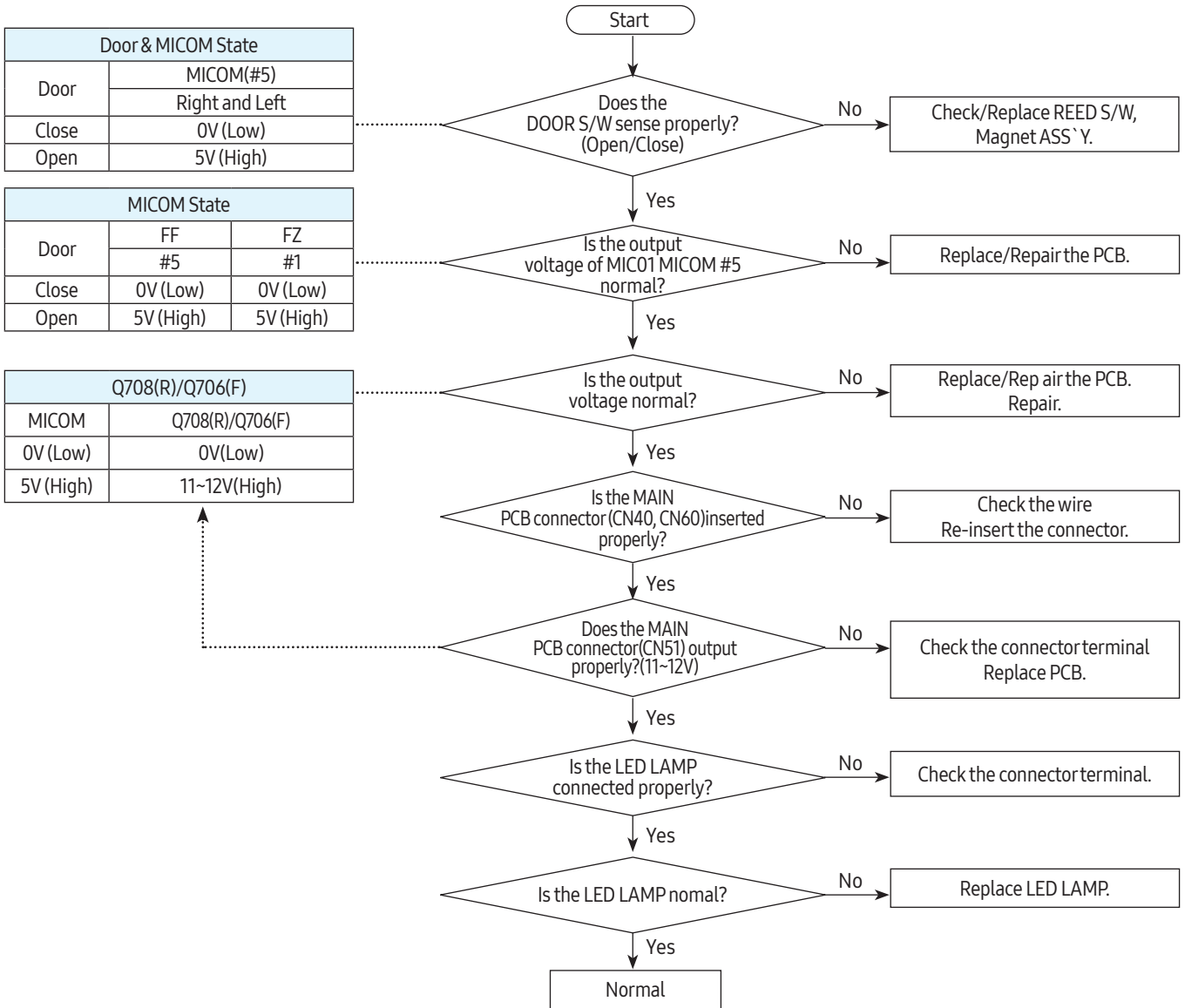

- 1) Measuring output voltage  
 - F LED : CN51 "24"(ORG) and CN51 "26"(W/GRY)  
 - R LED : CN51 "22"(GRN) and CN51 "13"(GRY)

R LED Lamp ON

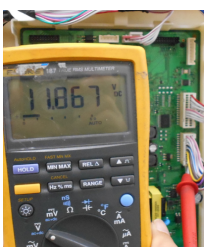

R LED Lamp OFF

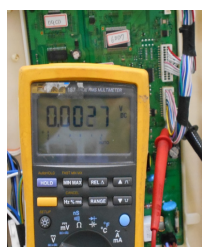

- F Door : CN51 "1"(ORG) and CN51 "3"(FLAT\_WHT)  
 - R Door : CN51 "10"(BLK) and CN51 "13"(GRY)

Close



Open



PIN Number

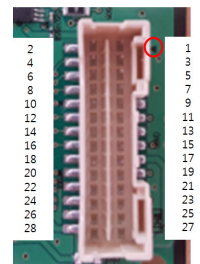

# CHECK THE INSTALLATION STATUS

## 6-10) If ICE Water is not supplied (OPTION)

1. Please shut the water supplying prior to repair.
2. Power is applied to the one end of wires. Be careful when disassembling not to get an electric shock.

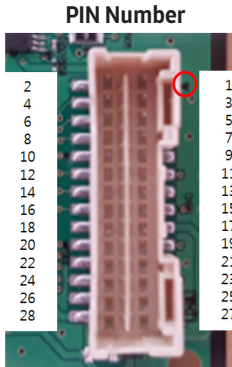

☞ Checking method of voltage Based on  
 1) Check the voltage of MIC #58 ↔  
 CN04 #2 - ICE Water valve waiting (about 0V)



2) Q719 ↔ CN04 #2  
 - ICE Water valve Waiting (about 12V±0.8V)  
 - ICE Water valve Operating (about 0.7V±0.5V)



3) Check the voltage of Water Valve operating (AC voltage)  
 ⇒ The Relay RY74 operating. CN71 -"7" ↔ CN70-"1"  
 - ICE Water valve waiting (about AC 0V)

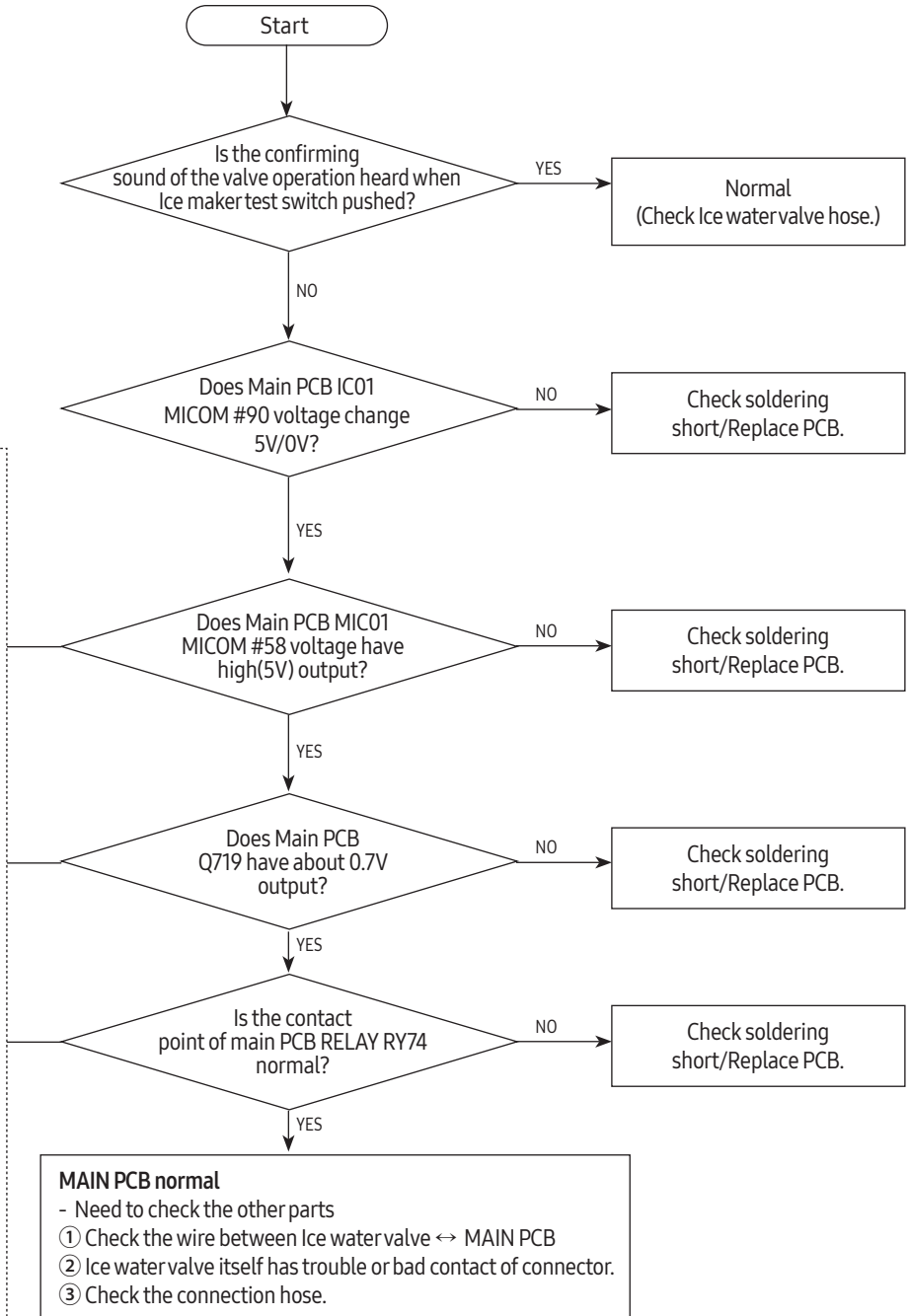
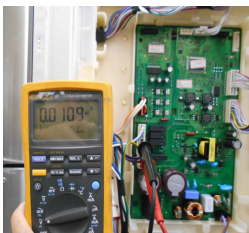









## CHECK THE INSTALLATION STATUS

### 6-11) LED blinking frequency depending on protecting functions

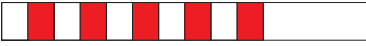
If Failure Condition is detected during compressor is operating, immediately stop Compressor operating and stand by 5 minutes. During this 5 minutes, RPM command signal is not available. It means, even if available RPM command signal is applied to the compressor, it does not work and keep standing by.

**Blinking time is 1 second and dwell time is 2 seconds.**

LED Blinking Frequency	Protecting Functions	Remarks
	Normal Operation	N/A
	Starting Failure	1. Short between COMP U,V, and W phase(CN04) 2. Short among IPM Pins(No. #1 ~ 26)
	SPM Fault	3. Drop the IPM operating Voltage under DC 13.5V 4. Other cases, check the COMP, cycle, etc.
	Abnormal Current Detection	1. Open the COMP wire(CN04) 2. Bad condition of R1(ex. Bad soldering.) 3. Other cases, check the COMP, cycle, etc.
	Motor Locked / Over RPM	1. Operating the locked rotor COMP within 5 second. 2. Operating the COMP under 1000 RPM more than 5second. 3. Occur the huge change of input voltage in a moment 4. Other cases, check the COMP, cycle, etc.
	Under Voltage	1. Drop the input voltage under AC 53V 2. Short resistor R312(DC link resistor)
	Over Voltage	1. Increase the input voltage over AC 155V 2. Short resistor among R309, R310 and R311 (DC link resistor)
	Communication error	1. Main – Inverter communication error
	IPM Shut Down	1. Check IPM, PBA case, Compressor Temperature 2. If IPM or Discrete IC Temperature 120°C over, blinking LED

LED blinking frequency depending on protecting functions.

## 7. PCB DIAGRAM

### 7-1) PCB Layout with part position

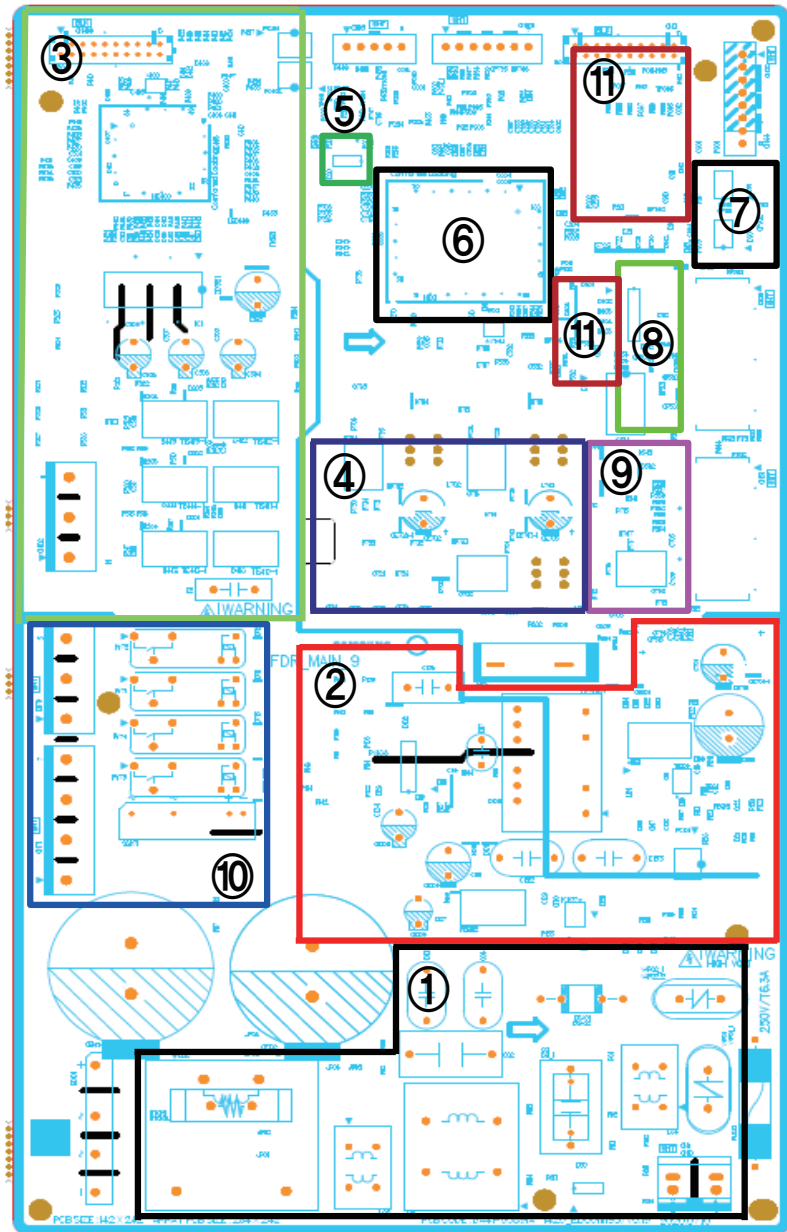

1. EMI FILTER part
2. DC 15V, 12V, 5V, GND supplied from SMPS PCB
3. Inverter circuit part
  - COMP Driving / Feedback Circuit
  - BOOTSTRAP Charger : It is an independent power circuit for the driving of the IMP High-Phase IGBT.
  - Current Pickup Circuit : It pickups the currents taken by the Shunt resistance and does the PWM DUTY control.
4. FAN MOTOR control part : To supply the power from 7V ~ 12V according to the motor types. (F,R,C)
5. EEPROM : Save and record every kinds of data.
6. Micom : control the regrigerator Ceramic resonator : generate the basic frequency of Micom operation. Reset IC : make Micom reset if input voltage of Micom is detected less than the specified voltage
7. Operate ICE-MAKER, supply power to MOTOR, and sense the variation of switch. (OPTION)
8. Main Micom ↔ Panel Micom serial communication circuit - Dispenser option input part (Water & Cover Ice route switch)
9. LED LAMP Control Circuit (F,R room Lamp)
10. Connector with AC load
11. Diode option setting area

# PCB DIAGRAM

## 7-2) Connector Layout with part position

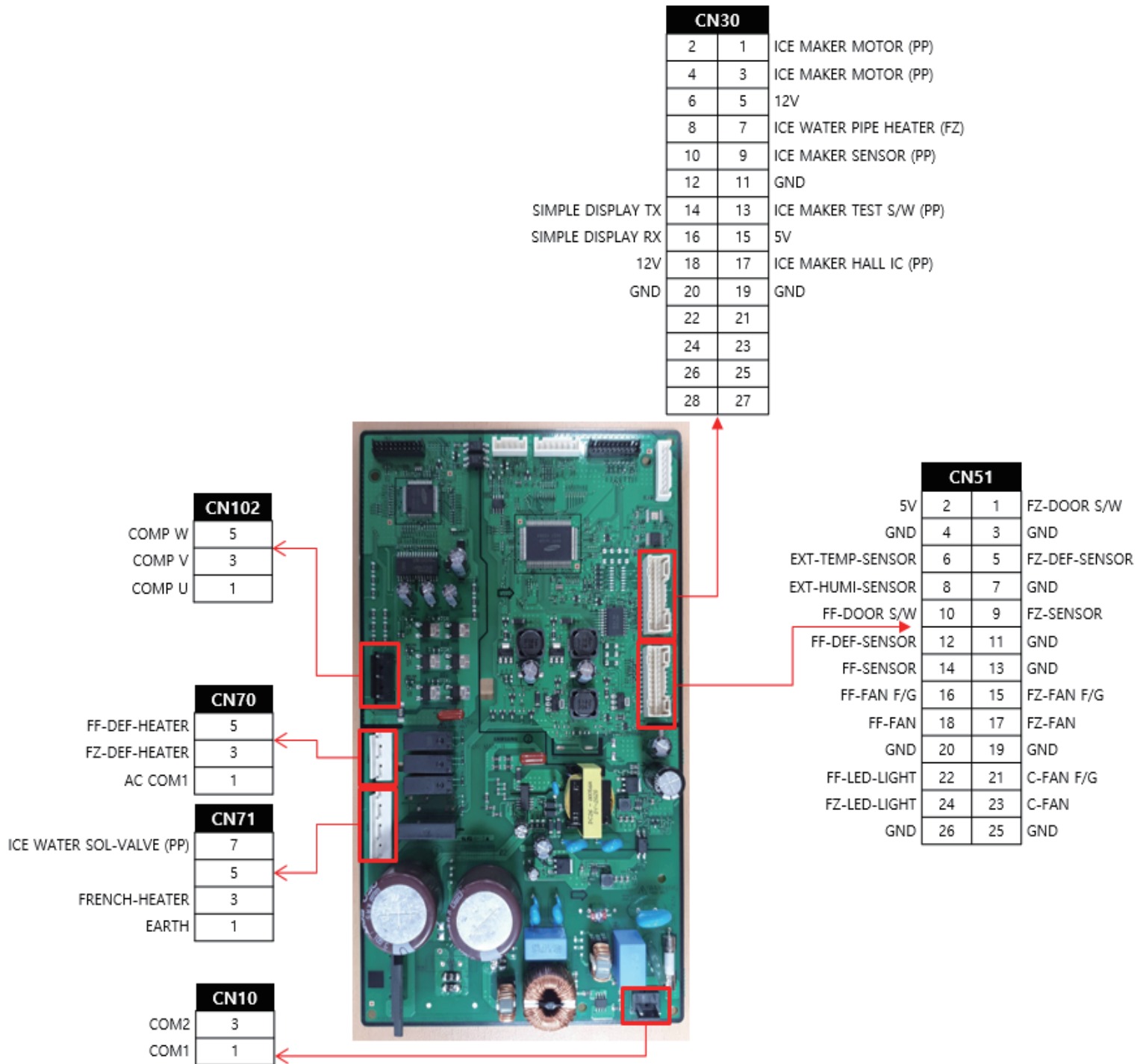

# 8. WIRING DIAGRAM

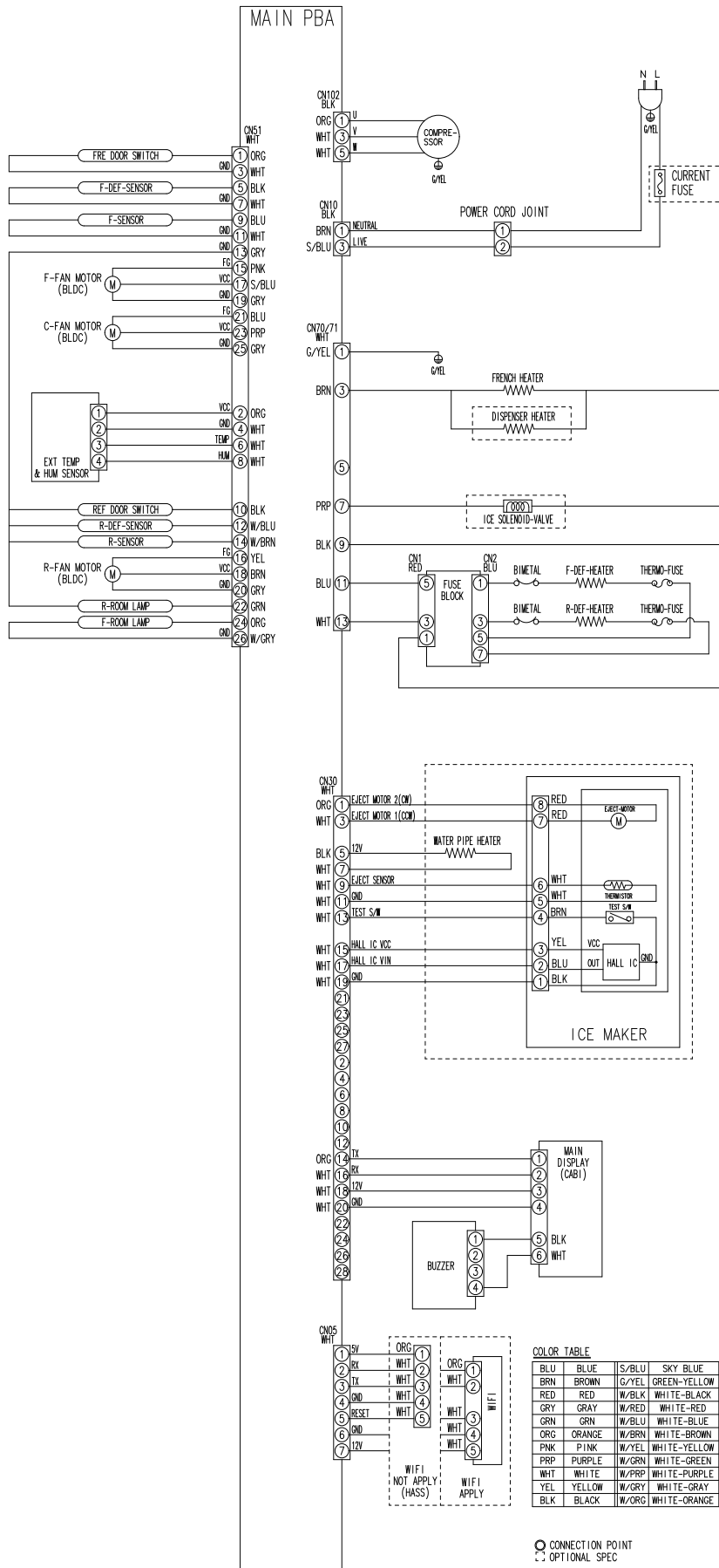

# 9. BLOCK DIAGRAM

## 9-1) Whole block diagram

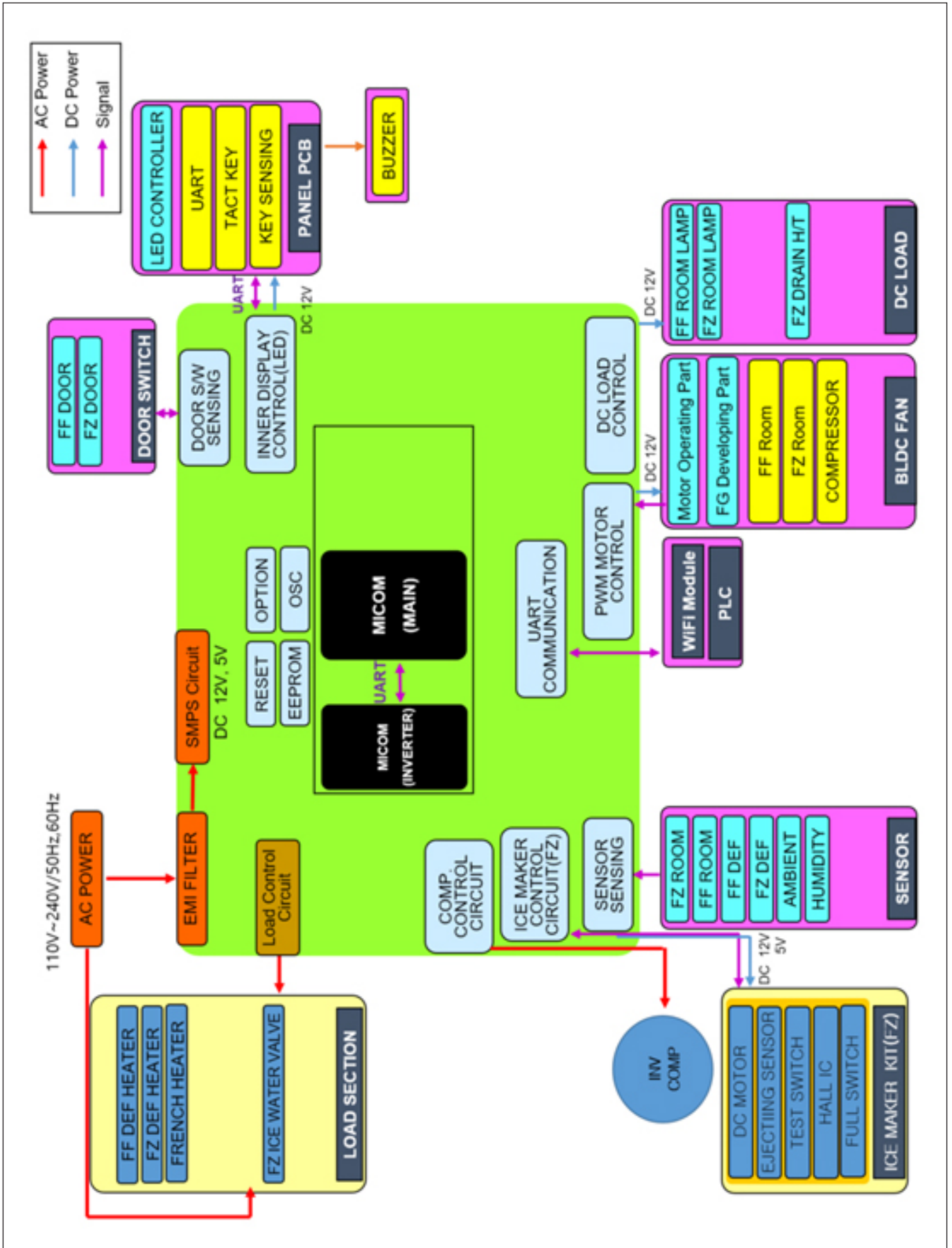



## REFERENCE INFORMATION

### 10-2) Trouble Shooting

PROBLEM	SOLUTION
The Refrigerator does not work at all or it does not chill sufficiently.	• Check that the power plug is properly connected.
	• Check the set temperature on the digital display is warmer than freezer or fridge inner temperature.
	• Try setting it to a lower temperature.
	• Is the Refrigerator in direct sunlight or located near a heat source?
	• Is the back of the Refrigerator too close to the wall and therefore keeping air from circulating?
The food in the Refrigerator is frozen	• Check the set temperature on the digital display is too low.
	• Try setting it to a warmer temperature.
	• Is the temperature in the room too low? Try setting it to a warmer temperature.
	• Did you store the food which is juicy in the coldest part of the Refrigerator? Try moving those items on the other shelves in fridge instead of keeping them in the Cool Select Pantry™.
You hear unusual noise or sounds.	• Check that the Refrigerator is level and stable.
	• Is the back of the Refrigerator too close to the wall and therefore keeping air from circulating?
	• Try locate the refrigerator keep away from the wall over 2 inches.
	• Was anything dropped behind or under the Refrigerator?
	• A "ticking" sound is heard from inside the Refrigerator. It is normal and occurs because various accessories are contracting or expanding according to the temperature of the Refrigerator interior.
The front corners and vertical hinged section of the appliance are hot and condensation is occurring.	• Some heat is normal as anti-condensators are installed in the vertical hinged section of the Refrigerator to prevent condensation.
	• Is the Refrigerator door ajar? Condensation can occur when you leave the door open for a long time.
	• If a sound that hit something is heard from inside the refrigerator, it is normal and occurs because ice dropping make a sound by periods.
You hear unusual noise or sounds.	• Check that the Refrigerator is level and stable.
	• Is the back of the Refrigerator too close to the wall and therefore keeping air from circulating?
	• Try locate the refrigerator keep away from the wall over 2 inches.
	• Was anything dropped behind or under the Refrigerator?
	• A "ticking" sound is heard from inside the Refrigerator. It is normal and occurs because various accessories are contracting or expanding according to the temperature of the Refrigerator interior.
The front corners and vertical hinged section of the appliance are hot and condensation is occurring.	• Some heat is normal as anti-condensators are installed in the vertical hinged section of the Refrigerator to prevent condensation.
	• Is the Refrigerator door ajar? Condensation can occur when you leave the door open for a long time.
	• If a sound that hit something is heard from inside the refrigerator, it is normal and occurs because ice dropping make a sound by periods.

## REFERENCE INFORMATION

PROBLEM	SOLUTION
Ice Maker is not producing ice.	• Did you wait for 12 hours after installation of the water supply line before Maker ice?
	• Is the water line connected and the shut-off valve opened?
	• Did you manually stop the ice Maker function?
	• Is the Freezer temperature too warm? Try setting the Freezer temperature lower.
You can hear water bubbling in the Refrigerator.	• This is normal. The bubbling comes from the Refrigerator coolant liquid circulating through the Refrigerator.
There is a bad smell in the Refrigerator.	• Check for spoiled food.
	• Foods with strong odors (for example, fish) should be tightly covered.
	• Clean out your Freezer periodically and throw away any spoiled or suspicious food.
Frost forms on the walls of the Freezer	• Is the air vent blocked? Remove any obstructions so air can circulate freely.
	• Allow sufficient space between the foods stored for efficient air circulation.
	• Is the Freezer drawer closed properly?
Water dispenser is not functioning.	• Is the water line connected and the shut-off valve opened?
	• Has the water supply line tubing been crushed or kinked? Make sure the tubing is free and clear of any obstruction.
	• Is the water tank frozen because the Refrigerator temperature is too low? Try selecting a warmer setting on the Digital display.

## REFERENCE INFORMATION

### 10-3) Q&A

Descriptions of symptoms	Check Points	Corrective Measures
▶ Noise (resonance) problems keep on even though the noise generating BLDC motors for both of the compartments are replaced several times. What does generate the resonance and how can it be settled down?	When the BLDC fan motor rotates in low RPM, The friction with air is quite high and it generates "grinding" noises.	If you replace the ambient thermistor with a 2.7K resistance (detecting 109.4°F), the BLDC fan motor rotates in high RPM, which reduces friction with air resulting in reduction of the "grinding" resonance.
▶ What causes the "knocking" noises? How to solve it?	It makes "knocking" or "branch breaking" noises when the liner and the shelves hit each other due to the fluctuation of the inside air pressure upon door open/close. Also, these noises occur when the liners and the shelves hit each other as the liners expand and contract due to the temperature change in both of the compartments.	Check the clearance between the selves and the liners. ① Freezer Shelves : Remove the trim shelves already attached and replace them with those supplied for service. ② Fridge Shelves : Because noise-preventing trim selves are not attached, it needs attaching.
▶ What is the solution if the same problem occurs even though the counter action in the service bulletin has been implemented already for the "knocking" noises?	Check if the selves wobble. If they do, have shelves sit firmly on their places.	
▶ What causes the liquid passing noises from the back of the refrigerator?	Refrigerant goes into the evaporator via the capillary tube in which the refrigerant expands as it circulates the cooling cycle. At this time, the refrigerant is in its liquid state and it starts evaporating as it reaches at the inlet of the evaporator with a bigger diameter, which causes the refrigerant noises. And, it gets worse when the refrigerant does not flow freely.	
▶ What is the solution for the compressor noises?	<b>For new refrigerators</b>	
	Check if the refrigerator is leveled.	Check if the refrigerator wobbles by shaking with hands.
	Check if there is enough clearance at the back of the refrigerator for the ventilation of the machine compartment.	If there is not enough clearance or it is blocked by things such as newspaper, there could be resonance noises.
	Required clearance around the product.	More than 2 inches from the back, 12 inches from the top and 4 inches from its sides.
▶ What is the solution for the compressor noises?	<b>For old refrigerators</b>	
	Dust could get built-up in the machine compartment. Then, its ventilation would get restricted which makes the refrigerator overheated resulting in the increase of the noise level.	Explain it to customers and let them clean dust or any other foreign substances in the machine compartment.
	As the vibration proof rubbers get hardened, noises generate during the comp operation. (The noise level is quite high.) → Replace the vibration proof rubbers.	The compressor is dislocated due to impact during its transportation such as moving-in. → Check if it's dislocated when it is more noisy after moving-in.
▶ During the comp start-up, iron friction noises occur. What causes them?	The reciprocation piston could get worn out or inner components could get dislocated.	

## REFERENCE INFORMATION

Descriptions of symptoms	Check Points	Corrective Measures
<p>▶ What can be checked when the unit sends out noises?</p>	<p>1. Check its symptoms and patterns. 2. Check if the unit is installed on a firm and leveled floor. 3. Check if the unit is installed close to the customer's living area. 4. Check if the panel on the machine compartment hits on the rear wall and the unit has enough clearance with the rear wall. 5. Check if the refrigerant pipes are shaped as normal.</p>	
<p>▶ Why is the fridge compartment not cool? (Not a defect)</p>	<p>Advise customers to adjust its temperature level to one or two step higher. For example, when the ambient temperature is low such as in winter (especially, when you use it in the morning with the door not being opened or closed during the night), the compartment temperature could get increased by 33.8~35.6°F. So, advise customers to shift its temperature level and explain to them that it does not affect its power consumption that much when its temperature setting is adjusted to one or two step lower.</p>	
<p>▶ Why is the food melt eventhough the display of the freezer compartment shows -4°F?</p>	<p>Check the compartment temperature with a thermometer.</p>	<p>If it is considered to be low cooling, When the BLDC motor fan does not rotate because its restriction is not picked up. When the evaporator is frozen-up (defrost it) Temp detection error according to the characteristic change of the thermistor (set the compartment temperature or replace the thermoistor.)</p>
<p>▶ What is the reason that vegetables get frozen even though the fridge compartment is set to MIN?</p>	<p>Replace the fridge thermistor because it could be faulty. 1st : Check if the thermistor works after referring to the self-diagnosis checklist on the MAIN-PCB cover. If the over-cooling keeps on even though there is no problem with the above, replace it.</p>	
<p>▶ What can be done when frozen food gets melt in the freezer compartment or it does not cool down?</p>	<p>Defrost it by using hot water and check the defrost system for any fault. And then, eliminate the root causes so as to prevent it from reoccurring.</p>	
<p>▶ Why doesn't the compressor operate upon power supply?</p>	<p>Upon the initial power on, the compressor starts operating after a five minute delay to protect the compressor. So, please wait until it starts operating.</p>	
<p>▶ Why does it send out "Ding Dong" or alarm sounds with the doors closed?</p>	<p>Check if the food sticks out preventing the doors from closing properly. If it send out the above sounds with the door closed well, the door switch may not have been pressed down completely. So, make sure for the door switches to be pressed completely. Still, if it does not stop going off, check the wiring connections because the door switch signals may not be inputted into the PCB. And, when the door switch is faulty or it is not pressed down completely, the fan does not rotate and it causes low-cooling advancing to a defrost problem.</p>	<p> <b>NOTE</b> When it comes to automatic models, the fan motor does not operate right on with the door closed after being opened. The fan motor for dual-evaporator refrigerators starts after a 50°F~second delay and when the ambient temperature is higher than 91.4°F, it starts after a minute.</p>

## REFERENCE INFORMATION

Descriptions of symptoms	Check Points	Corrective Measures
<p>▶ What can be done when it sends out much smell in the fridge and the freezer compartments after 2 months?</p>	<p>When the stored food sends out much smell.</p> <ul style="list-style-type: none"> <li>☞ Check if there is any food sending out sustaining smells. Dried squid, dried laver : Hold on them</li> <li><b>Pounded garlic</b> : Put it in an airtight container</li> <li><b>Medical herbs</b> : Make sure they are packed airtight. Replace the old packing or wrap with a new one.</li> <li><b>Others</b> : Check if the container is sealed or the food is packed airtight.</li> </ul> <ul style="list-style-type: none"> <li>☞ Check if the compartment temperature is normal and the food is contaminated.</li> <li>☞ Check if there are any overflow of side dishes on the shelves or the bottom of the compartments.</li> <li>☞ Put the food sending out much smell in an airtight bag or container.</li> <li>☞ Open the door and ventilate it. Also, clean liners, shelves, containers and door bins.</li> </ul>	
<p>▶ What is the cause and its counter action for chemical smells with new products?</p>	<p>During its delivery to customers, chemical smells from various components could build up inside of the compartments. So, please let the doors open for some time to use the unit.</p>	<p><b>Precautions</b> : Smells tend to get soaked into the liners or other components. If food generating much smell is stored inside, it would stick on to the liners and other components and it is so difficult to remove the smell. Especially, customers should take care in storing smelly food properly with its sealing being tight during the early period of the product's use.</p>
<p>▶ What can be done when the smell keeps on even though the deodorizers are cleaned?</p>	<ol style="list-style-type: none"> <li>1) Turn off the refrigerator (unplug the unit) and remain the door opened.</li> <li>2) Take out the food stored in the refrigerator. And then, take out all the shelves, door bins and containers, and put them in warm water. After cleaning them by using dish detergents and drying them, put them back to their locations.</li> <li>3) Remove the deodorizer and soak it in warm water more than 4 hours. After drying it in sunlight, put it back to its location.</li> <li>4) Throw away the smell-soaked plastic bags and put the food in new ones.</li> </ol>	
<p>▶ What causes the funny smell in water?</p>	<p>When it tastes and smells funny</p> <ul style="list-style-type: none"> <li>☞ It tastes funny even though it does not smell funny.</li> </ul>	<p>It could happen when remnants of the water filter or organics have been built up in the water tank. So, replace the water filter and the water tank together. If there is no replacement part and the water tank need cleaning, use dish detergents and make sure to clean the inside without any detergents remaining inside.</p>

# SAMSUNG

Europe, CIS, Mideast & Africa : [gspn1.samsungcsportal.com](http://gspn1.samsungcsportal.com)  
Asia : [gspn2.samsungcsportal.com](http://gspn2.samsungcsportal.com)  
North & Latin America : [gspn3.samsungcsportal.com](http://gspn3.samsungcsportal.com)  
China : [china.samsungportal.com](http://china.samsungportal.com)

– This Service Manual is a property of Samsung Electronics Co., Ltd.  
Any unauthorized use of Manual can be punished under applicable  
International or domestic law.