

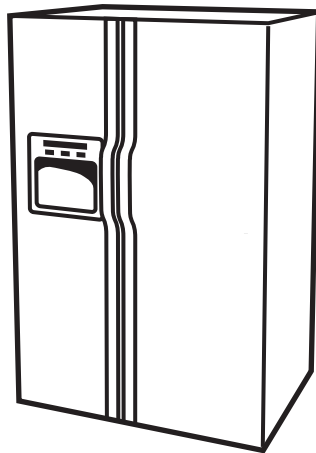

GE Consumer & Industrial

TECHNICAL SERVICE GUIDE

Profile/GE Side-by-Side Refrigerators with Electronic Touch Controls



MODEL SERIES:

GSS20

GSS22

GSS25

PUB # 31-9110 4/04





IMPORTANT SAFETY NOTICE

The information in this service guide is intended for use by individuals possessing adequate backgrounds of electrical, electronic, and mechanical experience. Any attempt to repair a major appliance may result in personal injury and property damage. The manufacturer or seller cannot be responsible for the interpretation of this information, nor can it assume any liability in connection with its use.

WARNING

To avoid personal injury, disconnect power before servicing this product. If electrical power is required for diagnosis or test purposes, disconnect the power immediately after performing the necessary checks.

RECONNECT ALL GROUNDING DEVICES

If grounding wires, screws, straps, clips, nuts, or washers used to complete a path to ground are removed for service, they must be returned to their original position and properly fastened.

GE Consumer & Industrial
Technical Service Guide
Copyright © 2004

All rights reserved. This service guide may not be reproduced, in whole or in part, or in any form, without written permission from the General Electric Company.

Table of Contents

Auger Does Not Work	24
Circuit Board	8
Clad Door Panel	10
Component Location	6
Components	8
Condenser Fan and Motor	9
Condenser Fan Does Not Work	20
Control Panel	12
Damper Does Not Work	19
Defrost Heater Does Not Work	21
Diagnostic Aid	14
Diagnostic Chart	15
Dispenser Trim	8
Door Gasket	11
Duct Door Does Not Open	19
Evaporator Fan and Motor	13
Evaporator Fan Does Not Work	20
Evaporator Thermistor Does Not Work	18
Freezer Light Does Not Work	22
Freezer Thermistor Does Not Work	18
Fresh Food Compartment Light and Switch	10
Fresh Food Light Does Not Work	22
Fresh Food Thermistors	8
Fresh Food Thermistor Does Not Work	18
Icemaker	9
Icemaker Does Not Work	24
Illustrated Parts Catalog	27
Mini-Manual Location	5
No Communication Between the Main Control Board and the Dispenser Board	17
Nomenclature	5
Schematic	25
Technical Data	4
Thermistor Values Chart	18
Troubleshooting	14
Troubleshooting Chart	16
Warranty Information	36
Water Chilling Tube Repair	13
Water Dispenser Does Not Work	23
Wheel Assembly	9
Wiring Diagram	26

Technical Data

DISCONNECT POWER CORD BEFORE SERVICING
IMPORTANT - RECONNECT ALL GROUNDING DEVICES

All parts of this appliance capable of conducting electrical current are grounded. If grounding wires, screws, straps, clips, nuts or washers used to complete a path to ground are removed for service, they must be returned to their original position and properly fastened.

ELECTRICAL SPECIFICATIONS

Thermistor calibration: kilo-ohm resistance.....@ 0°F 62.79
 @ 37°F 24.48
 @ 77°F 10.00
 Defrost Control adaptive system
 Overtemperature Thermostat 140-110°F

ELECTRICAL RATING

Maximum Current Leakage 0.75 mA.
 Maximum Ground Path Resistance 0.14 Ohms

NO LOAD PERFORMANCE

Control Position 5/5 and Ambient of 65°F - 90°F
 Fresh Food, °F 34-41
 Frozen Food, °F (-3) -3
 Run Time, % @ 65 Ambient 23-35%
 Run Time, % @ 90 Ambient 48-60%

REFRIGERATION SYSTEM

Refrigerant Charge (R134a) 4.25 ounces
 Compressor 980 BTU/hr
 Minimum Compressor Capacity 23 inches
 Minimum Equalized Pressure
 @ 70°F 55 PSIG
 @ 90°F 63 PSIG

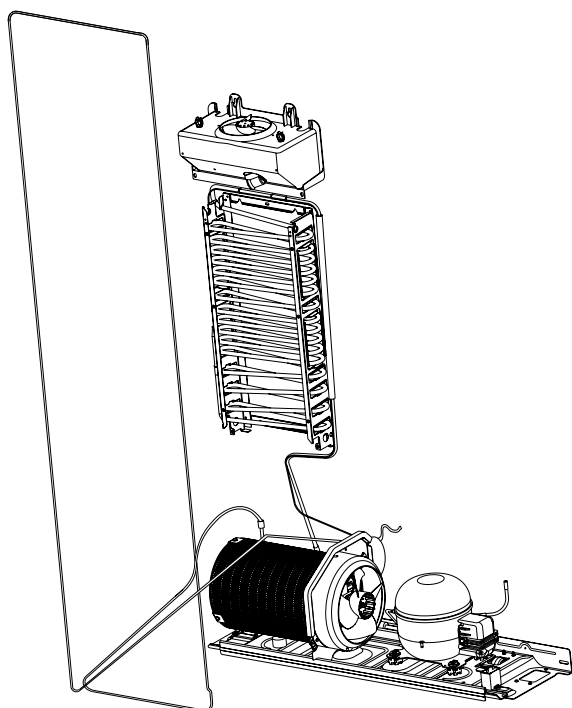

IMPORTANT SAFETY NOTICE

This information is intended for use by individuals possessing adequate backgrounds of electrical, electronic and mechanical experience. Any attempt to repair a major appliance may result in personal injury and property damage. The manufacturer or seller cannot be responsible for the interpretation of this information, nor can it assume any liability in connection with its use.

INSTALLATION

Clearance must be provided for air circulation
 AT TOP 1"
 AT SIDES 0.13"
 AT REAR 1"

AIR FLOW

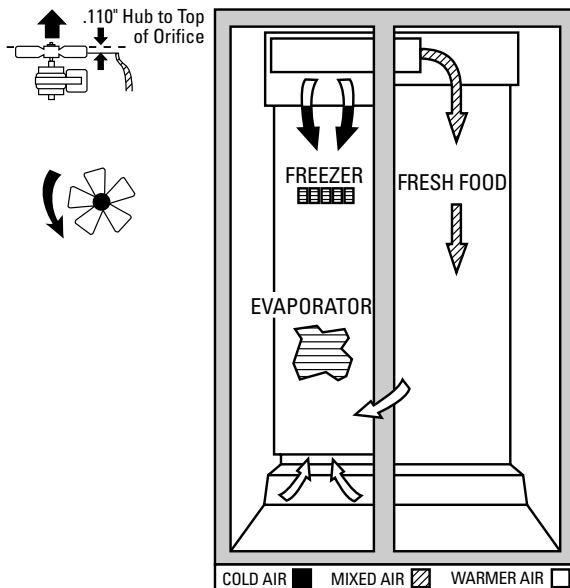

REPLACEMENT PARTS

FF Temp Control Housing	WR55X10276
PTCR	WR07X10009
Overload	WR08X10028
Capacitor	WR62X0080
Heater and Bracket Asm.....	WR51X10055
Motor DC Condenser Fan.....	WR60X10053
Motor DC Evaporator Fan	WR60X10043
Board Asm Main Control	WR55X10037
Compressor Replacement Kit	WR87X10041
Sensor Temperature	WR50X10027
Overtemperature Thermostat.....	WR50X10015

Nomenclature

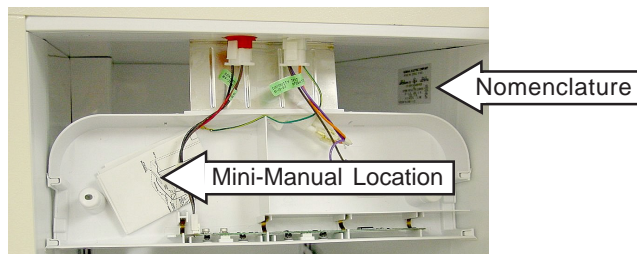
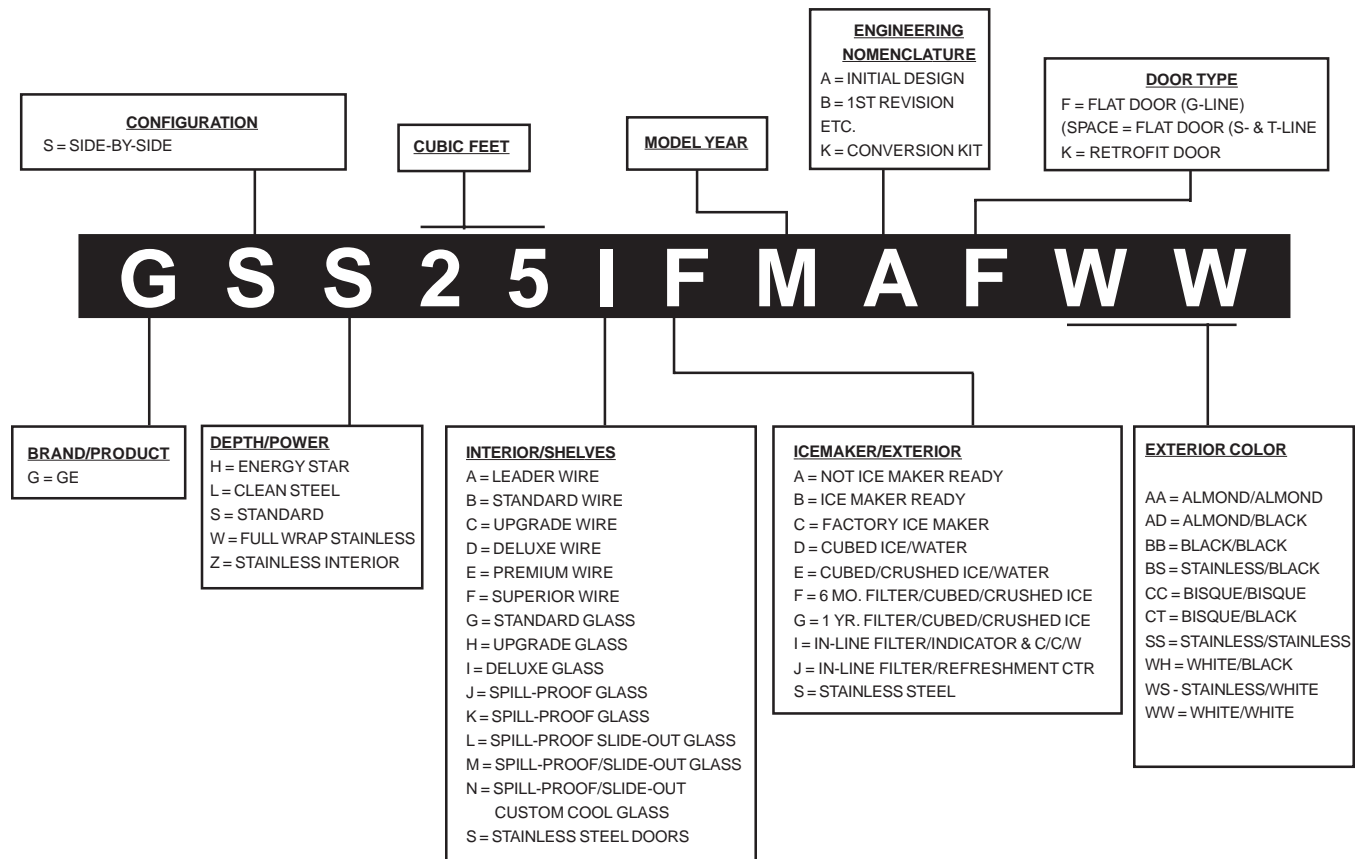

The Mini-Manual is located in the control console.

Serial Number

The first two numbers of the serial number identify the month and year of manufacture.

Example: **AG123456S** = January, 2004

A - JAN	2005 - H
D - FEB	2004 - G
F - MAR	2003 - F
G - APR	2002 - D
H - MAY	2001 - A
L - JUN	2000 - Z
M - JUL	1999 - V
R - AUG	1998 - T
S - SEP	1997 - S
T - OCT	1996 - R
V - NOV	1995 - M
Z - DEC	1994 - L

The letter designating the year repeats every 12 years.

Example:

T - 1974
T - 1986
T - 1998

Note: The technical sheet is located under the control panel.

Component Location

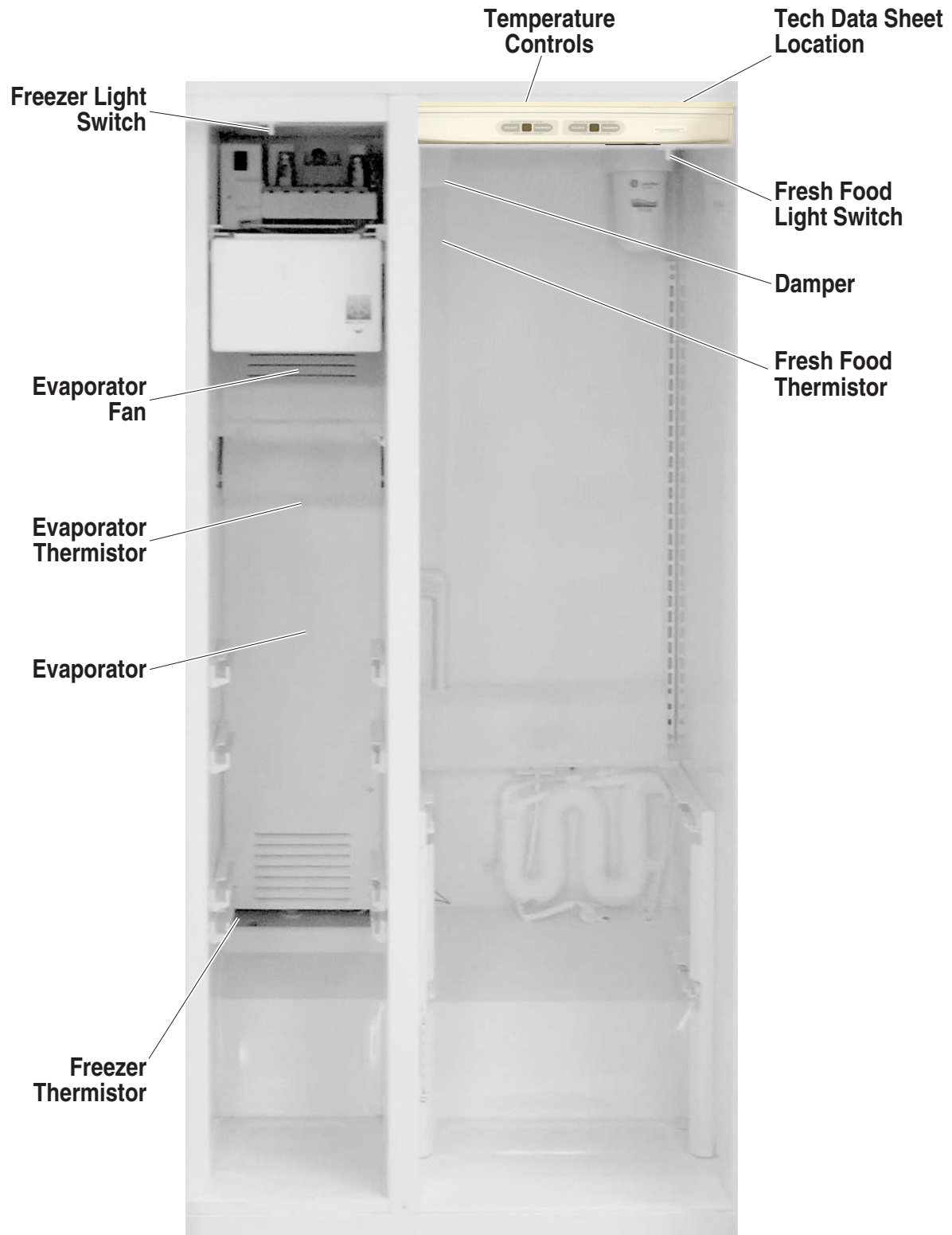

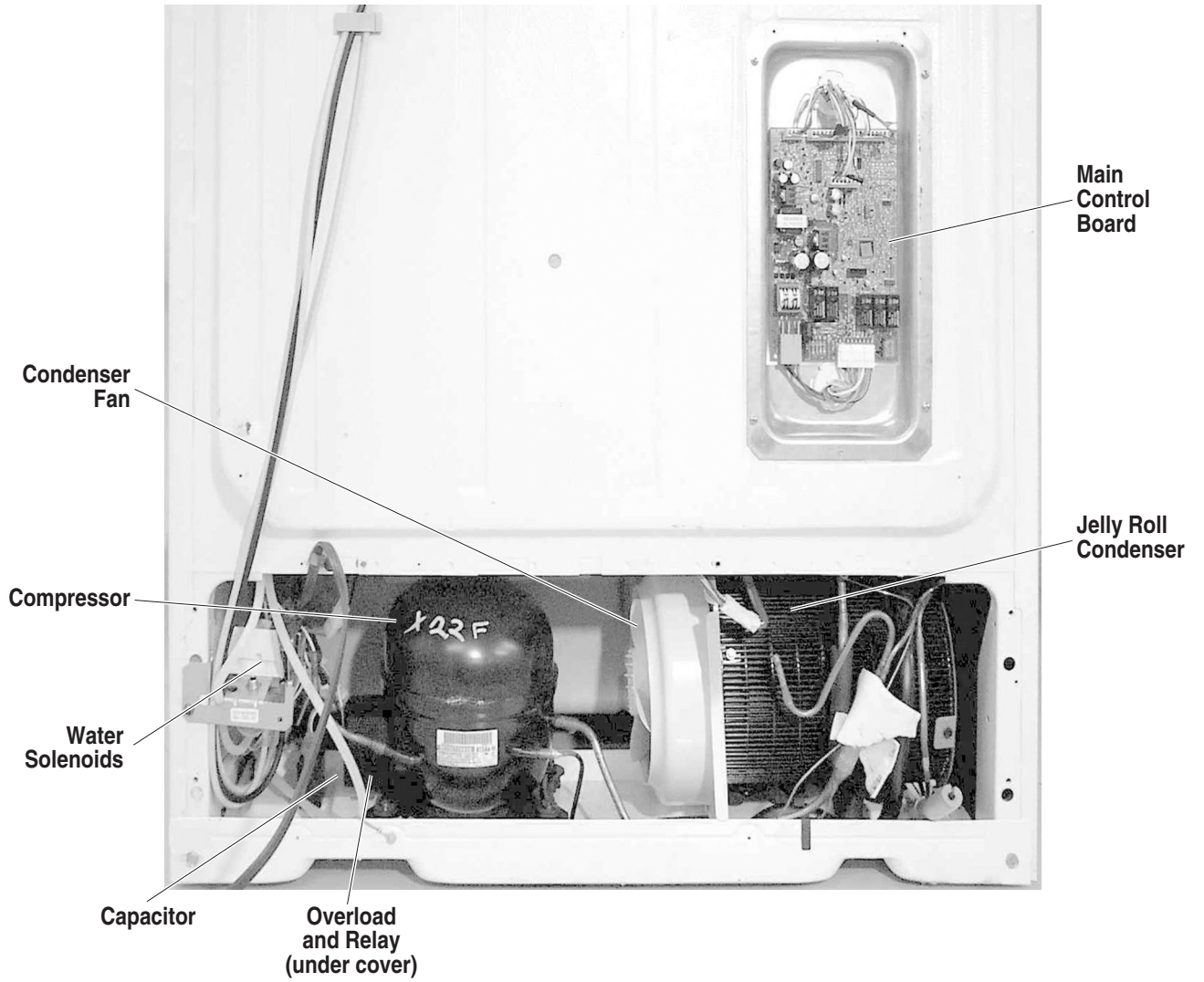

Components

Dispenser Trim

Removal and Replacement

To remove the dispenser trim, insert small flat-blade screwdriver in the slots located at the bottom of the trim and lift up.

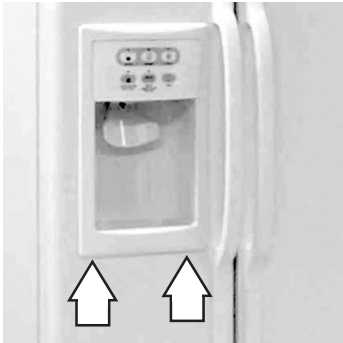

Pull the trim from the trim tab holes.

To install the dispenser trim, align the trim tabs with the holes in the freezer door and press the trim onto the freezer door.

Fresh Food Thermistors

The fresh food thermistors are located at the upper and lower portions of the fresh food compartment.

Removal and Replacement

With a small flat-blade screwdriver, unlock the tabs and remove the assembly.

Remove the thermistor from the cover and disconnect the wire connector.

Circuit Board

The circuit board is located on the back side of the refrigerator.

Removal and Replacement

To access the circuit board, remove 4 screws that hold the circuit board cover in place and remove the circuit board cover.

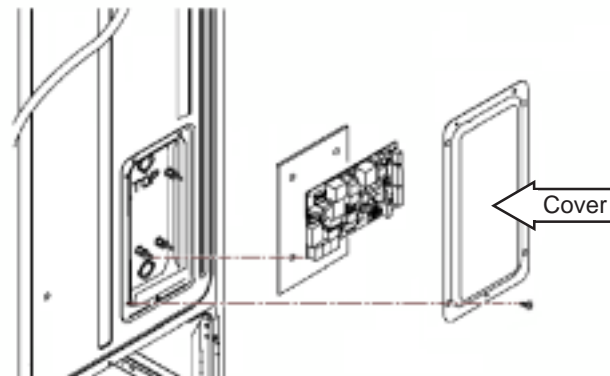

Disconnect 3 electrical connectors. Remove the 3 screws that hold the circuit board in place, then remove the circuit board.

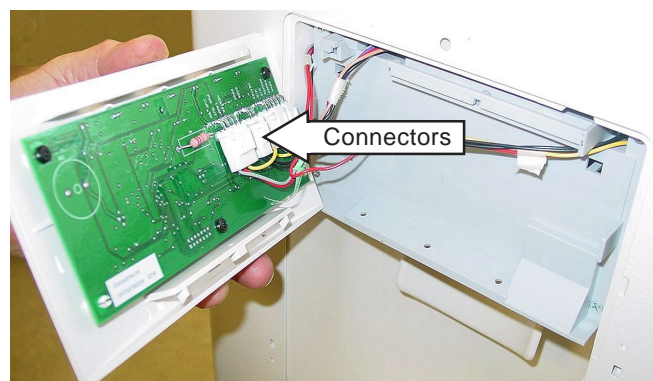

Wheel Assembly

Removal and Replacement

Unplug the refrigerator and lay the refrigerator on its back side.

Remove 3 screws from the bottom of the wheel assembly.

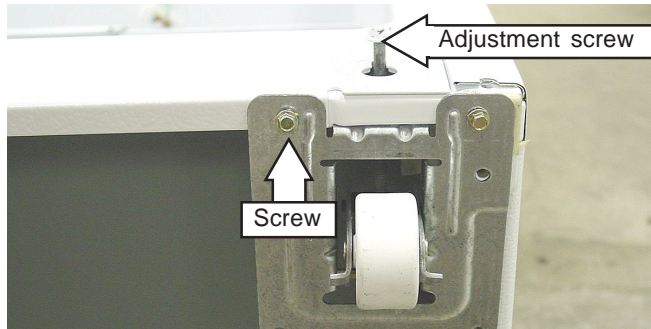

Remove the wheel assembly by guiding the wheel adjustment screw through the wheel adjustment screw hole.

Icemaker

The orange and brown wires at the icemaker will read 120 VAC.

Removal and Replacement

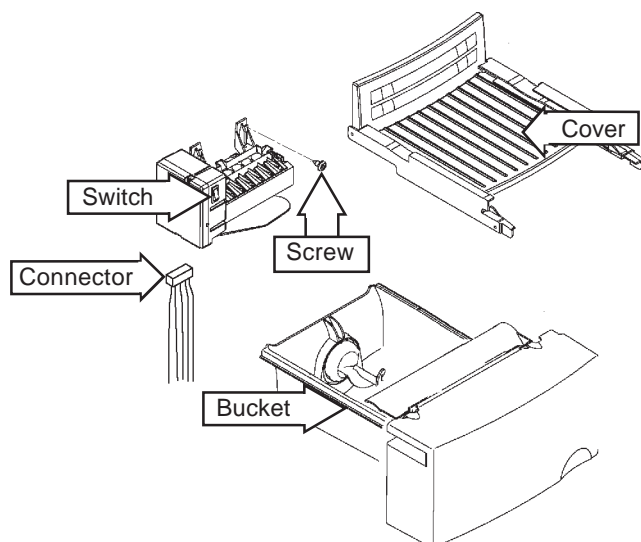

Turn the icemaker switch to the **OFF** position.

Remove the icemaker bucket and cover.

Unplug the icemaker connector.

Remove 2 screws, then remove the icemaker.

Condenser Fan and Motor

Note: The condenser fan harness is 3 inches longer to accommodate maintenance.

Removal and Replacement

Remove 6 screws, then remove the cover from the rear of the refrigerator.

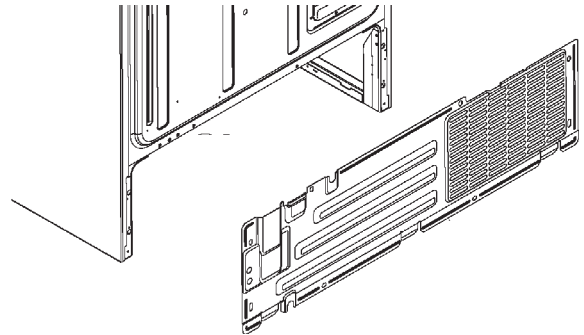

Pull the fan blades off of the end of the fan shaft.

Caution: The grommet in the fan motor bracket may fall out.

Remove 2 screws from the fan motor bracket, then remove the fan motor bracket.

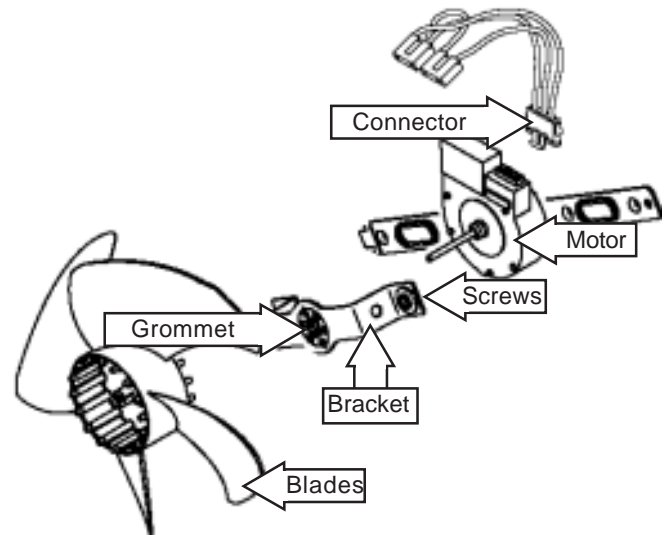

Remove the fan motor and disconnect the electrical connector.

Fresh Food Compartment Light and Switch

The fresh food light socket will read 120 VAC with the door open.

Removal and Replacement

Remove 2 screws securing the control panel to the refrigerator ceiling.



Disconnect the electrical connector shown below. Squeeze the tab and remove the light assembly.

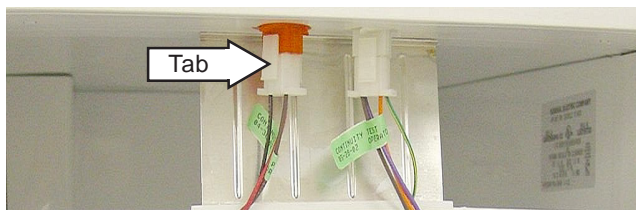

Disconnect the electrical connector from the fresh food compartment light switch. Squeeze the tab and push the light switch through the control panel.

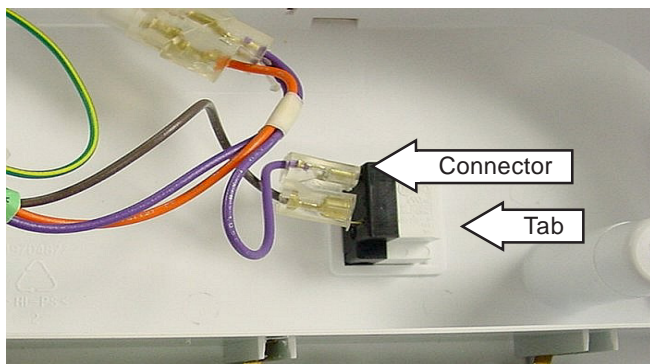

Clad Door Panel

The clad door panel is not on all models. Models with the clad door require special cleaning and handling procedures.

Removal and Replacement

Note: The screws that secure the clad panel to the door require a Torx-30 screwdriver.

Remove the hinge cover, 2 screws, and the upper hinge plate.

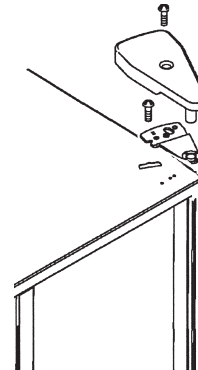

Note: Upper and lower door hinge shafts are 1/2 inch longer. The toe plate grille and top hinge covers have been modified to adapt to these changes.

Lift the door off of the lower hinge.

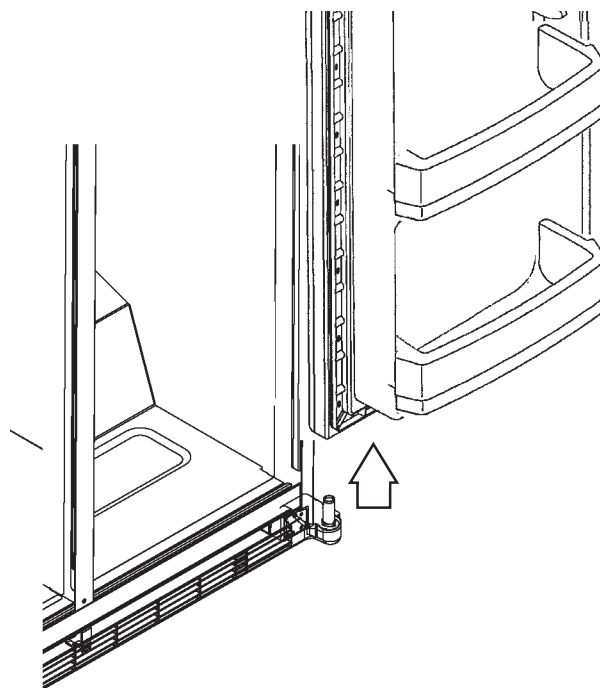

Remove 6 screws from the top, bottom, and side of the door. Remove the clad panel from the door.

Remove 2 screws and washers from the door handle.

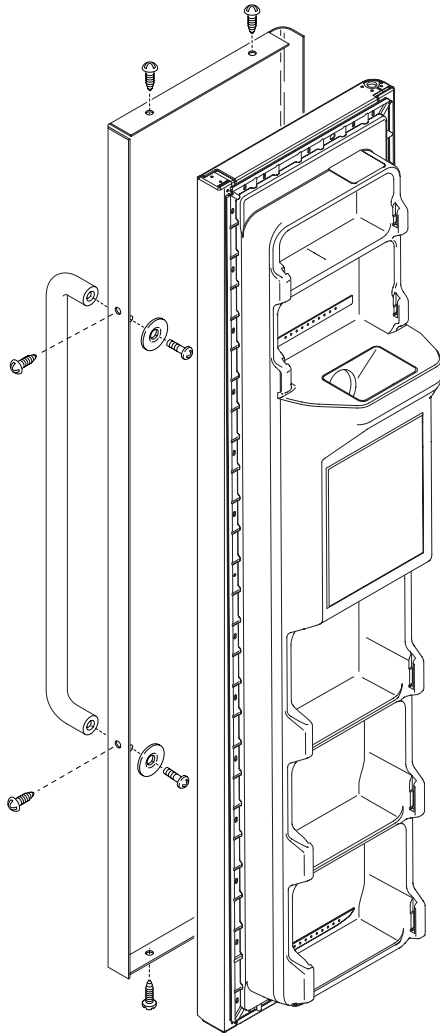

Door Gasket

The freezer and fresh food door gaskets are installed in a form-fitted slot in each foam-insulated door liner.

Removal and Replacement

Open the door. Grasp the gasket and pull until the molded gasket separates from the door liner.



GEA00923

Control Panel

Control panels in the fresh food section and on the freezer door are fitted with tactile control buttons. The main control board will have 120 VAC on the connectors from pins J-11 to J7-9.

Removal

Disconnect power. Remove 2 screws from bottom of control panel.



Pull the control panel down and disconnect the electrical connector to the light switch.

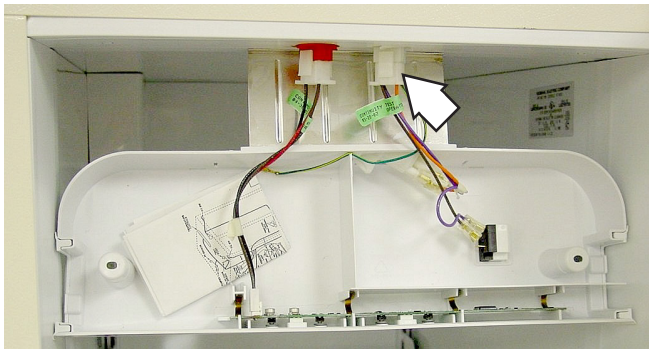

Note: Four spring clips hold the tactile buttons in place between the control panel housing and the circuit board. The tactile buttons will fall from their positions when the circuit board is removed.

Remove the 4 spring clips as follows:

Insert the head of a small flat-blade screwdriver under the spring clip and against the circuit board.

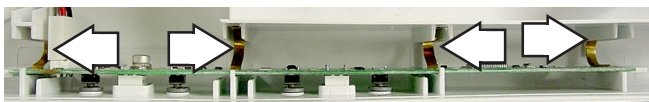

Note: Springs clips are retained in place under tension. Cover spring clips with your hand to prevent them from springing loose.

Carefully twist and lift the point of the spring clip from the retaining notch of the circuit board.

Set the control panel face down on a flat surface and remove the circuit card from the control panel.

Note: Be careful not to lose the four tactile buttons.

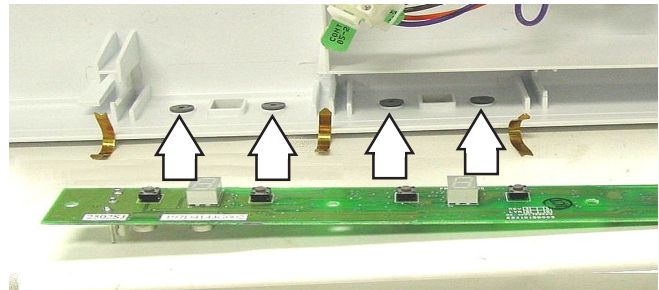

Remove 4 tactile buttons from control panel housing.

Remove electrical connector from circuit board.

Replacement

Connect electrical connector to circuit board.

Install 4 tactile buttons in the control panel housing.

Set circuit board in groove aligning the two 7-segment LEDs in their slots.

Note: Make sure circuit board is firmly seated in control panel groove.

Install 4 spring clips with arrow pointing toward circuit board. Push spring clip into groove until it snaps into place.

Position the tactile control panel inside the refrigerator.

Connect the electrical connectors to the light switch.

Install the 2 screws in the bottom of the tactile control panel.

Water Chilling Tube Repair

The water tank has been replaced with a water chilling tube. The water chilling tube allows the cooled air to contact a greater amount of water surface. The 36 feet of 5/16-in. plastic tubing can be repaired using the quick connector WR02X10471.

Removal and Replacement

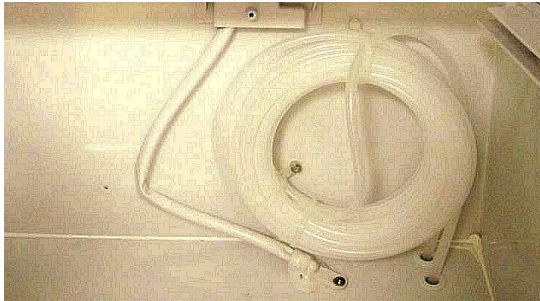

Turn the water supply off and unplug the refrigerator.

Lift the front of the fresh-produce shelf and slide it to the back of the refrigerator.

Remove the fresh-produce shelf glass from the refrigerator.

Lift and remove air deflector/light shield.

Remove the fruit/vegetable drawer.

Locate the damaged area in the water tube.

Note: If there is only one leak, cut one loop from the water tube roll containing the damaged area. If there is more than one leak, cut the water tube roll at both ends and replace the entire roll.



Insert the cut end of the water tube into a quick disconnect until it stops, then insert the other cut end of the water tube into the other side of the quick disconnect until it stops.

Plug in the refrigerator, turn the water source on, and check the chilled drinking water system for leaks.

Replace the fruit/vegetable drawer, fresh-produce shelf glass, and the air deflector/light shield.

Evaporator Fan and Motor

Removal and Replacement

Remove the shelves and drawers from the fresh food compartment.

Remove 4 screws from the rear panel and remove the rear panel.

Pull the fan blade off of the fan blade shaft.

Remove 2 screws from the motor brackets and remove the brackets.

Insert the fruit/vegetable drawer.

Remove the fan motor.

Note: The grommets on the fan motor brackets are pressed into place and may come off.

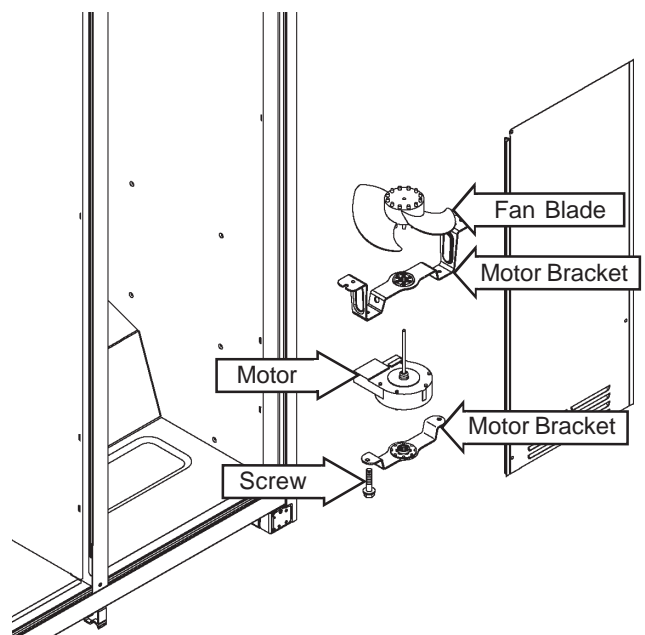

Troubleshooting

Diagnostic Aid

Note: Not all diagnostic tests are available on all models. See Diagnostic Chart, on next page, for details.

The purpose of the diagnostic aid is to allow, through a touch control board, the operation of individual components and test circuits on electronic refrigerators that do not contain built-in diagnostics. This includes all electronic models with a 4-pad touch control and electronic models with temperature knobs.

The following 3 parts are required to assemble the diagnostic aid:

- **WX05X14999** Wiring harness
- **WR55X10092** Temperature control board
- **WR55X10068** Touch control membrane and housing

Mount the temperature control board in the touch control housing and connect the ribbon cable.

Connect the long (single connector) end of the test harness to the J2 connector on the temperature control board.

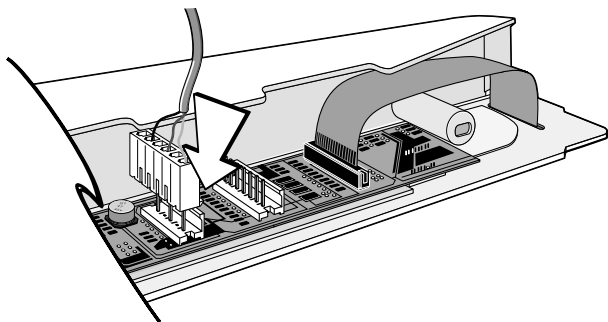

Connect the other end of the test harness to the refrigerator using the appropriate plug for the model being tested.

Note: On steel liner models with a 4-pad temperature control (no filter reset), you must disconnect the original touch control and plug the cabinet harness directly onto the diagnostic aid control board.

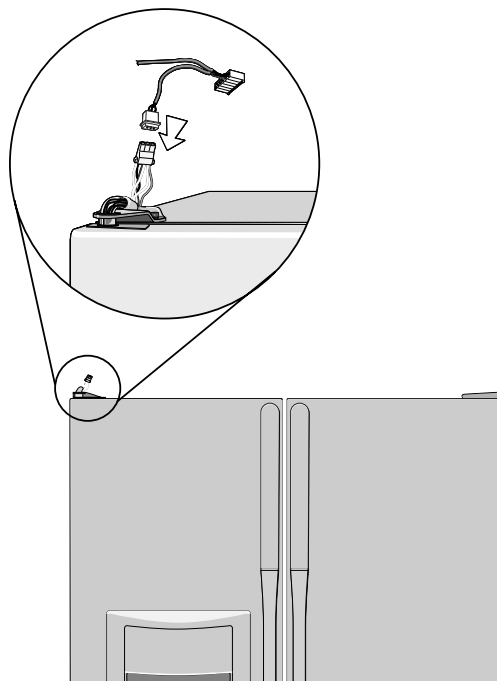

Enter the diagnostic mode by pressing both the freezer temperature (colder and warmer) pads and the refrigerator temperature (colder and warmer) pads simultaneously.

Note: All 4 pads must be held for approximately 3 seconds. A blinking "0" in both displays indicates the refrigerator has entered the test mode.

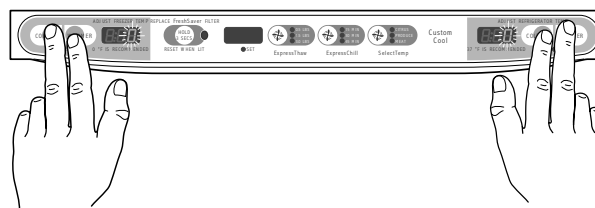

Press and release any pad (other than the temperature pads) to activate the test mode. Then, enter the display numbers as shown in the Diagnostic Chart for the test desired.

Press and release any pad (other than the temperature pads) to activate that test.

Note: Selected models have limited test capability. See the COMMENTS column for clarification.

Diagnostic Chart

FREEZER DISPLAY	FRESH FOOD DISPLAY	DIAGNOSTICS	RESULTS	COMMENTS
0	2	Communication check between Temperature Control and Main Control	"P" on freezer display if OK, "F" if problem is found.	
0	4	Communication check between Dispenser Control and Main Control	"P" on freezer display if OK, "F" if problem is found.	Dispenser models only.
0	5	Encoder Test	As the knob is rotated, the display will show the corresponding setting.	Only for models with temperature control knobs.
0	7	Control and Sensor System Test	Checks each thermistor and displays "P" for pass and "0" for fail.	See Note 1.
0	8	Duct Door Test	Opens the dispenser duct door for 10 seconds, then closes.	Only for dispensers with 5 or more touch pads.
1	0	Dampers Test	Opens each damper, pauses briefly, and then closes.	Includes Custom Cool dampers if applicable.
1	1	Fan Test	Cycles through each fan for 10 seconds.	
1	2	100% Run Time	Sealed system on 100% of the time. Times out after 1 hour.	
1	3	Prechill Test	Starts Prechill mode. Unit returns to normal on its own.	
1	4	Defrost Test	Toggles on the Defrost cycle. See Note 2.	Must press again to turn heaters off. See Note 2.
1	5	Main Control Reset	Causes a system reset.	
1	6	Exit Diagnostic Mode	Causes a temperature control board reset.	

Note 1. Display order is: #1 = Fresh Food 1, #2 = Fresh Food 2, #3 = Custom Cool, #4 = Evaporator, #5 = Freezer. Thermistor test results are: P = Pass, 0 = Fail, S = Short to 5 VDC, B = Bad amplifier (replace main control).

Note 2. You **must** enter the defrost test again to toggle the defrost heater off at the end of the test. The heater will not come on if the evaporator thermistor is warm. Refer to Service Guide 31-9072 for additional information.

Troubleshooting Chart

	Auger does not work	Water dispenser does not work	Icemaker does not work	Freezer light does not work	Freezer heater does not work	Freezer fan does not work	Fresh food heater does not work	Defrost fan does not work	Condenser fan does not work	Evaporator fan does not work	Damper does not open	Duct door does not work	Fresh food thermistor does not work	Freezer Thermistor does not work	Evaporator Thermistor does not work	No Comm between the Dispenser and Main Control Boards	
Main Control Board	●	●	●	●	●	●	●	●	●	●	●	●	●	●	●	●	
Dispenser Board	●	●															
Evaporator Thermistor			●														
Freezer Thermistor				●													
Fresh Food Thermistor					●												
Duct Door Magnet						●											
Damper							●										
Evaporator Fan								●									
Condenser Fan									●								
Defrost Heater										●							
Overtemperature Thermostat											●						
Fresh Food Door Switch													●				
Fresh Food Light Bulb														●			
Freezer Door Interlock															●		
Freezer Light Bulb																●	
Dispenser Water Valve																●	
Icemaker																	●
Water Valve																	●
Auger																	●
																	Page 24
																	Page 24
																	Page 23
																	Page 22
																	Page 22
																	Page 21
																	Page 20
																	Page 20
																	Page 19
																	Page 19
																	Page 18
																	Page 18
																	Page 17

No Communication Between the Main Control Board and the Dispenser Board

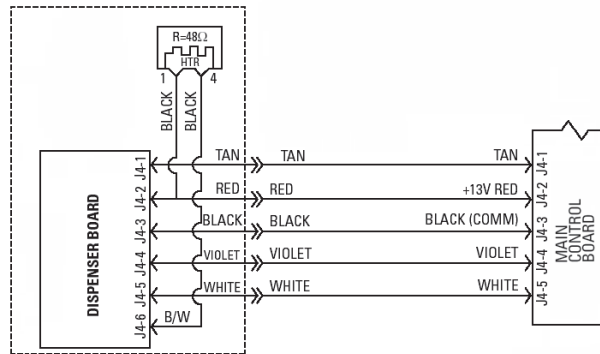
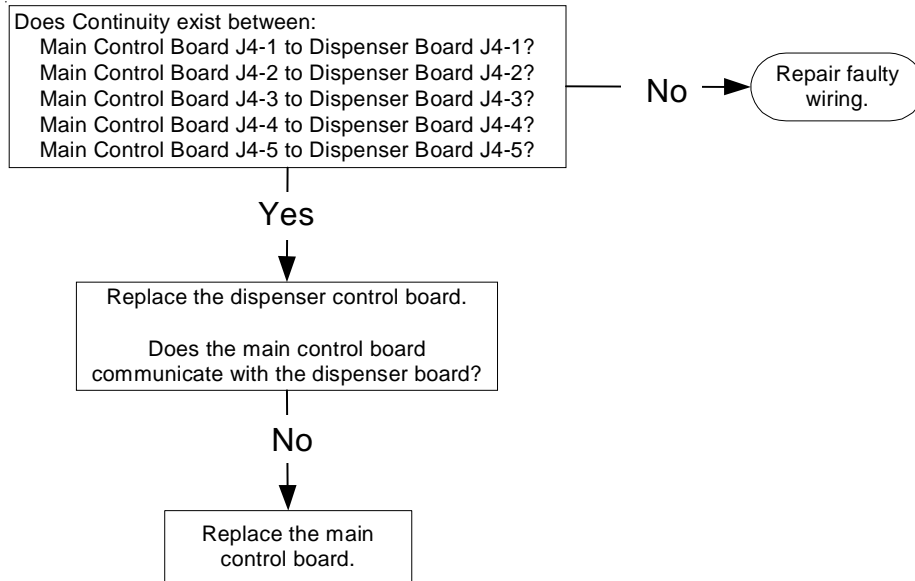

Evaporator Thermistor Does Not Work

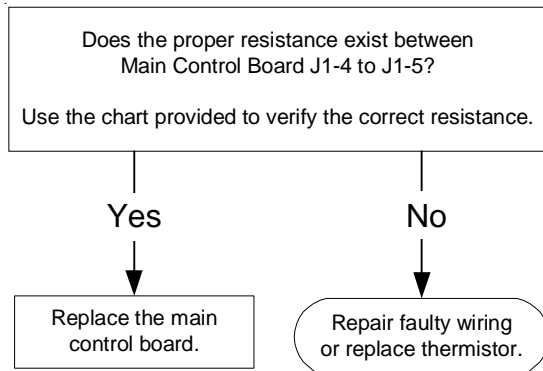

Thermistor Values		
Temperature Degrees (C)	Temperature Degrees (F)	Resistance in Kilo-Ohms
-40	-40	166.8 KΩ
-35	-31	120.5 KΩ
-30	-22	88 KΩ
-25	-13	65 KΩ
-20	-4	48.4 KΩ
-15	5	36.4 KΩ
-10	14	27.6 KΩ
-5	23	21 KΩ
0	32	16.3 KΩ
5	41	12.7 KΩ
10	50	10 KΩ
15	59	7.8 KΩ
20	68	6.2 KΩ
25	77	5 KΩ
30	86	4 KΩ
35	95	3.2 KΩ
40	104	2.6 KΩ
45	113	2.2 KΩ
50	122	1.8 KΩ
55	131	1.5 KΩ
60	140	1.2 KΩ

Freezer Thermistor Does Not Work

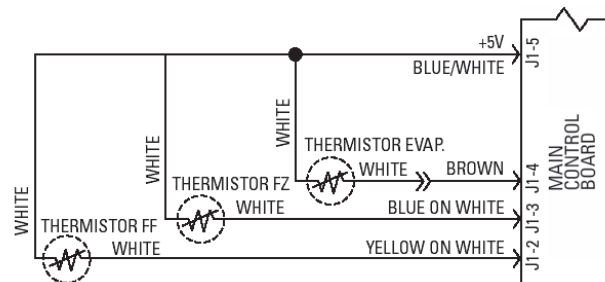
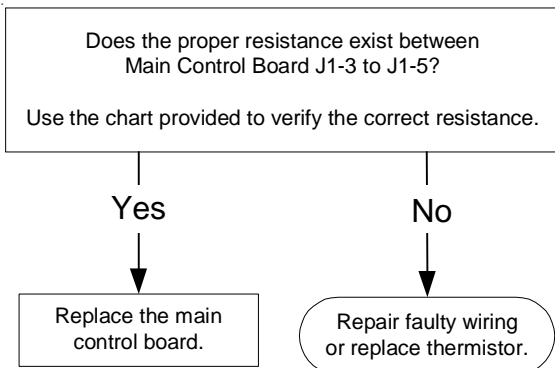

Fresh Food Thermistor Does Not Work

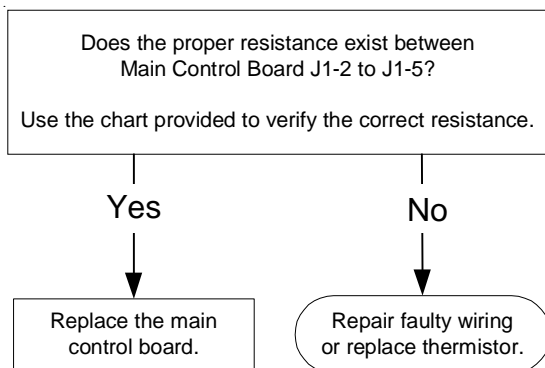

Duct Door Does Not Open

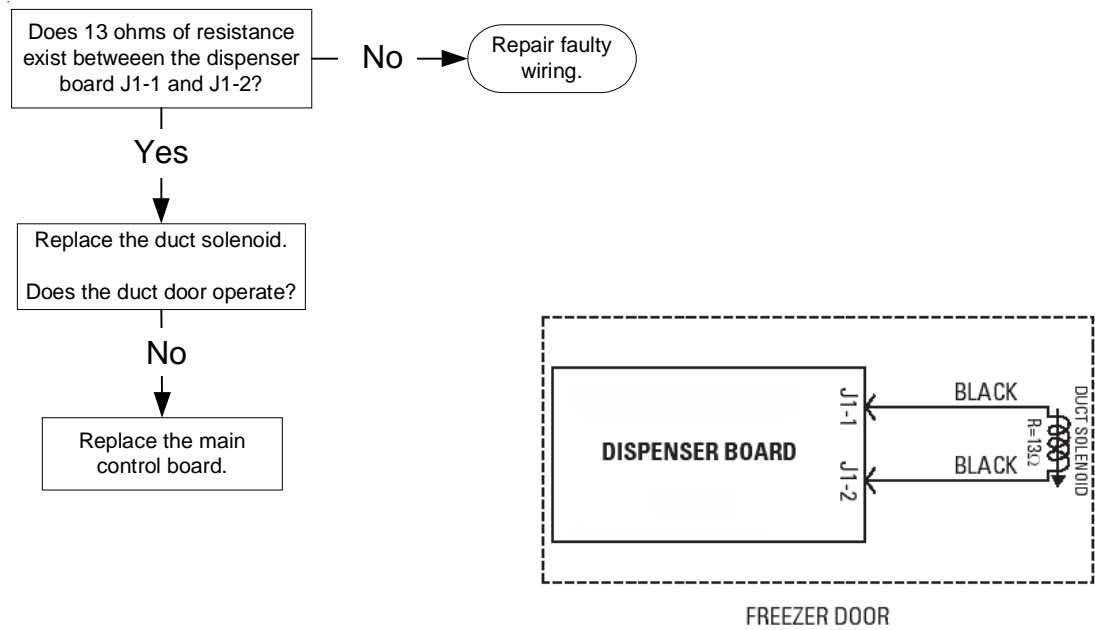

Damper Does Not Work

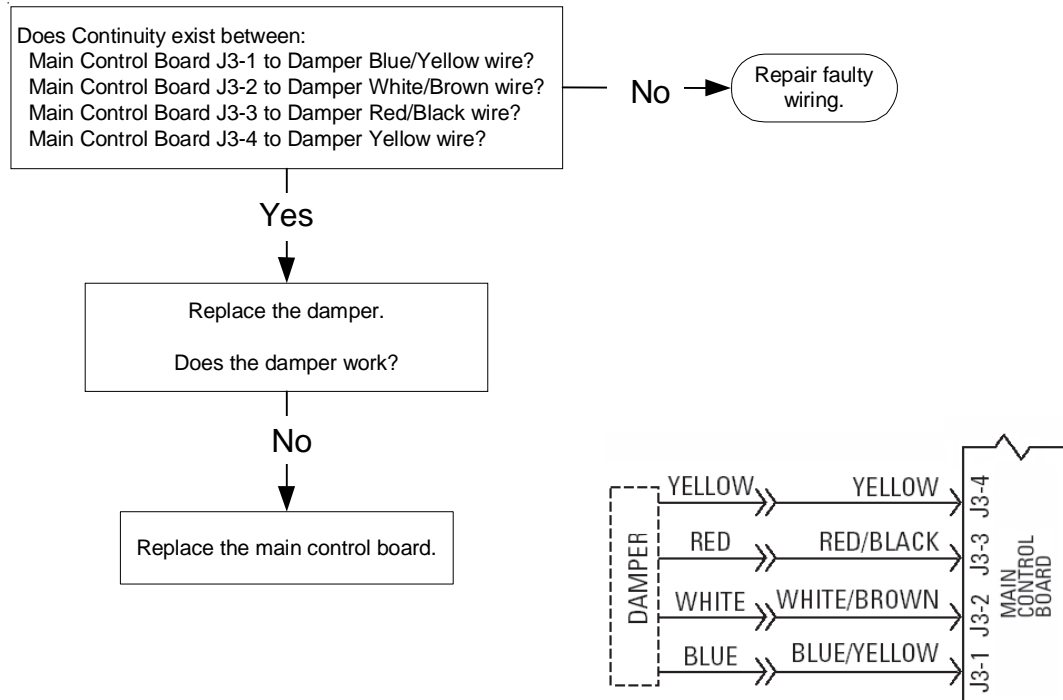

Evaporator Fan Does Not Work

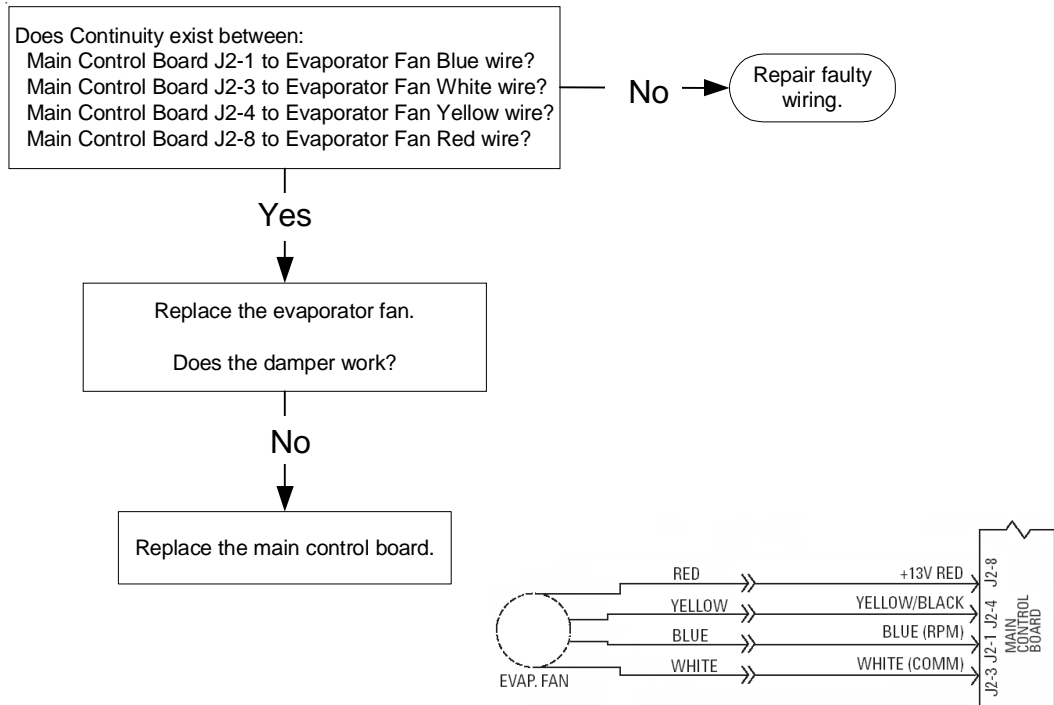

Condenser Fan Does Not Work

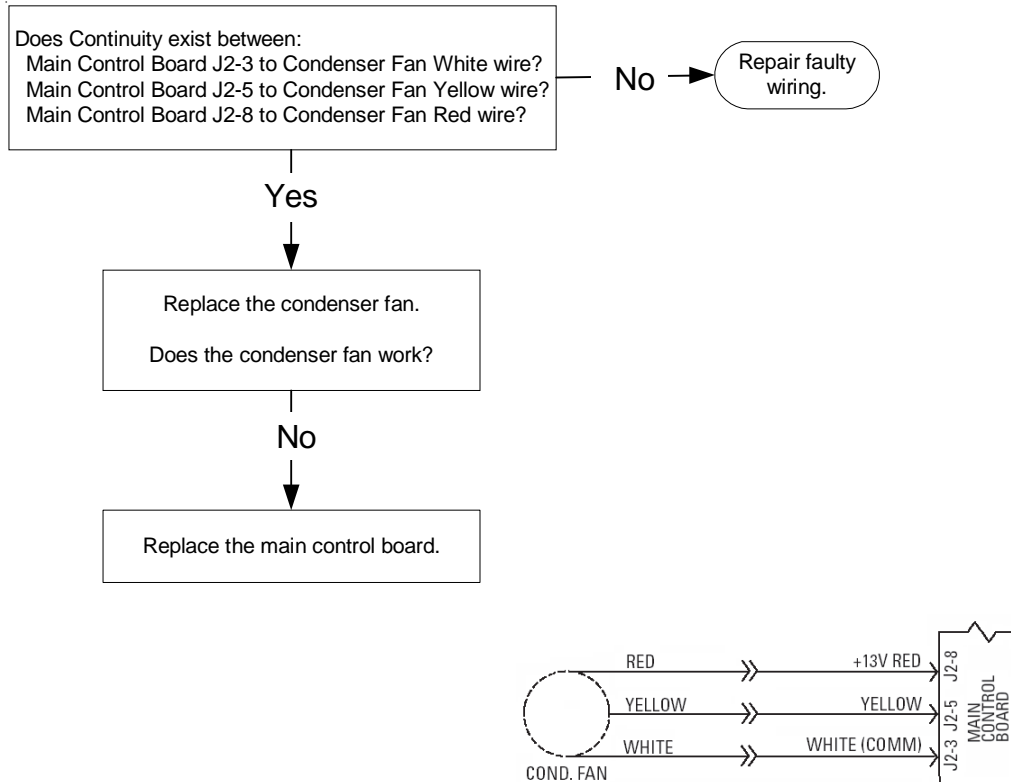

Defrost Heater Does Not Work

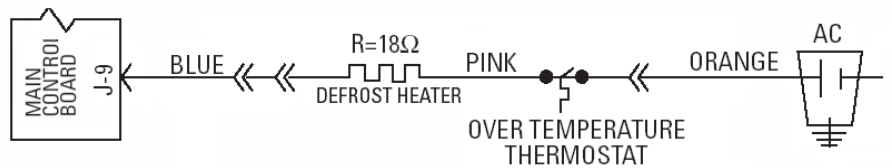
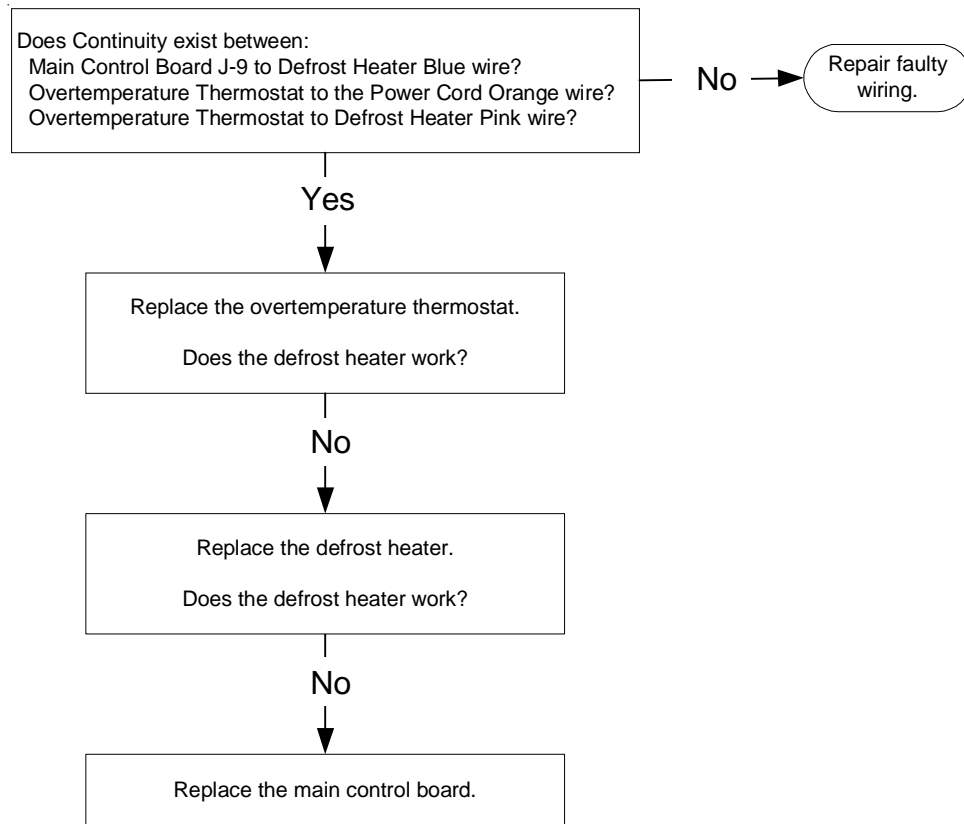

Fresh Food Light Does Not Work

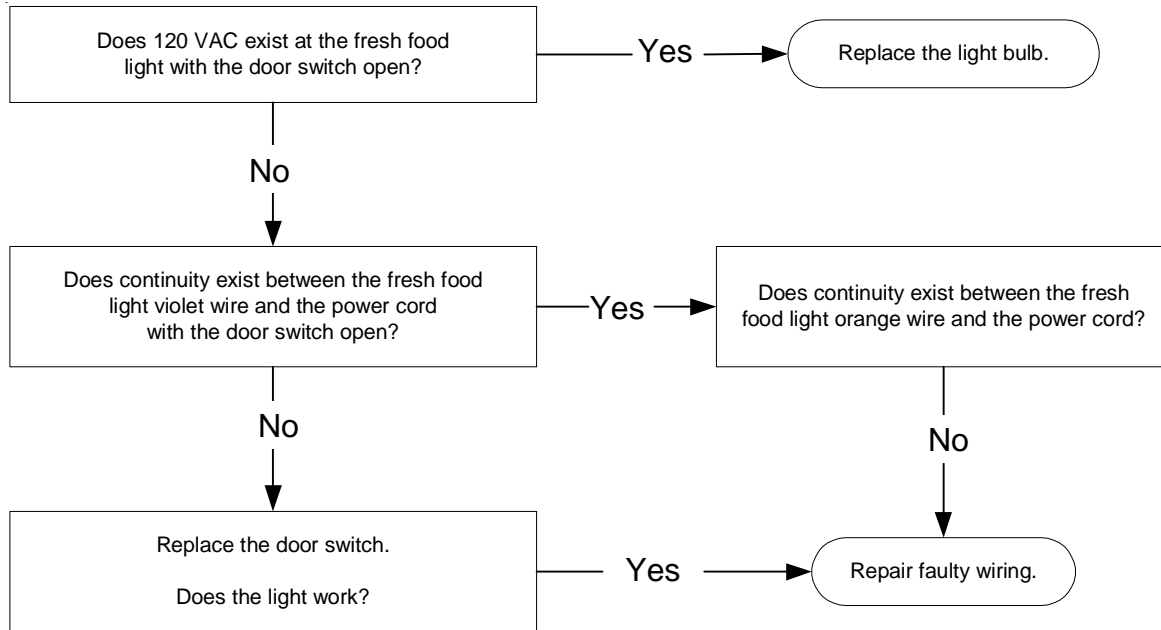

LINE VOLTAGE

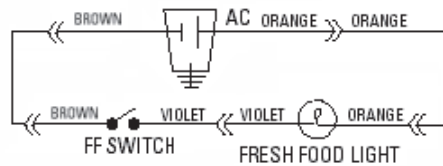

Freezer Light Does Not Work

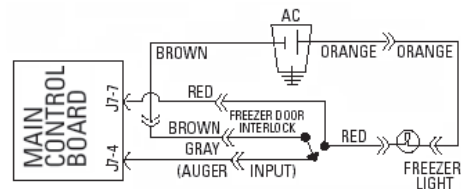
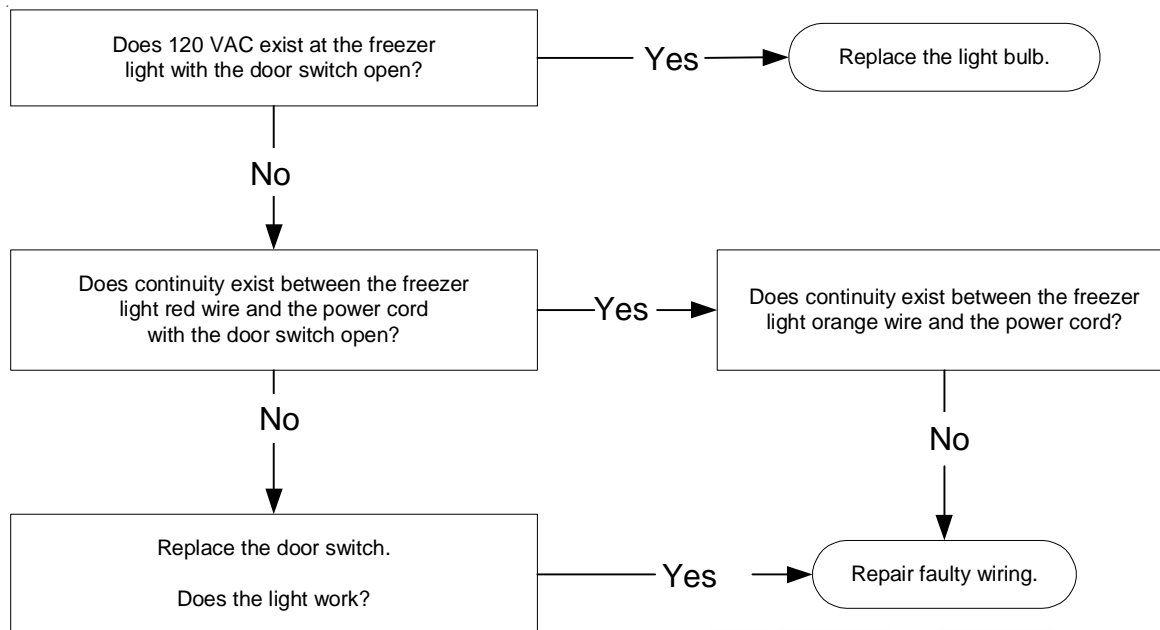

Water Dispenser Does Not Work

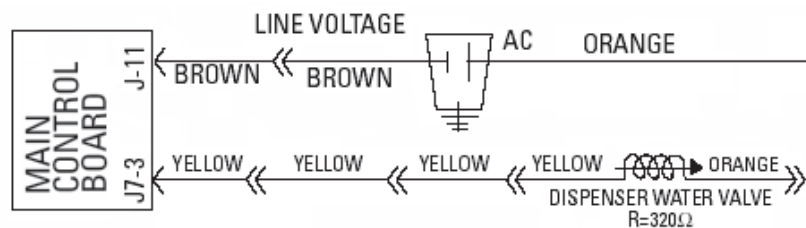
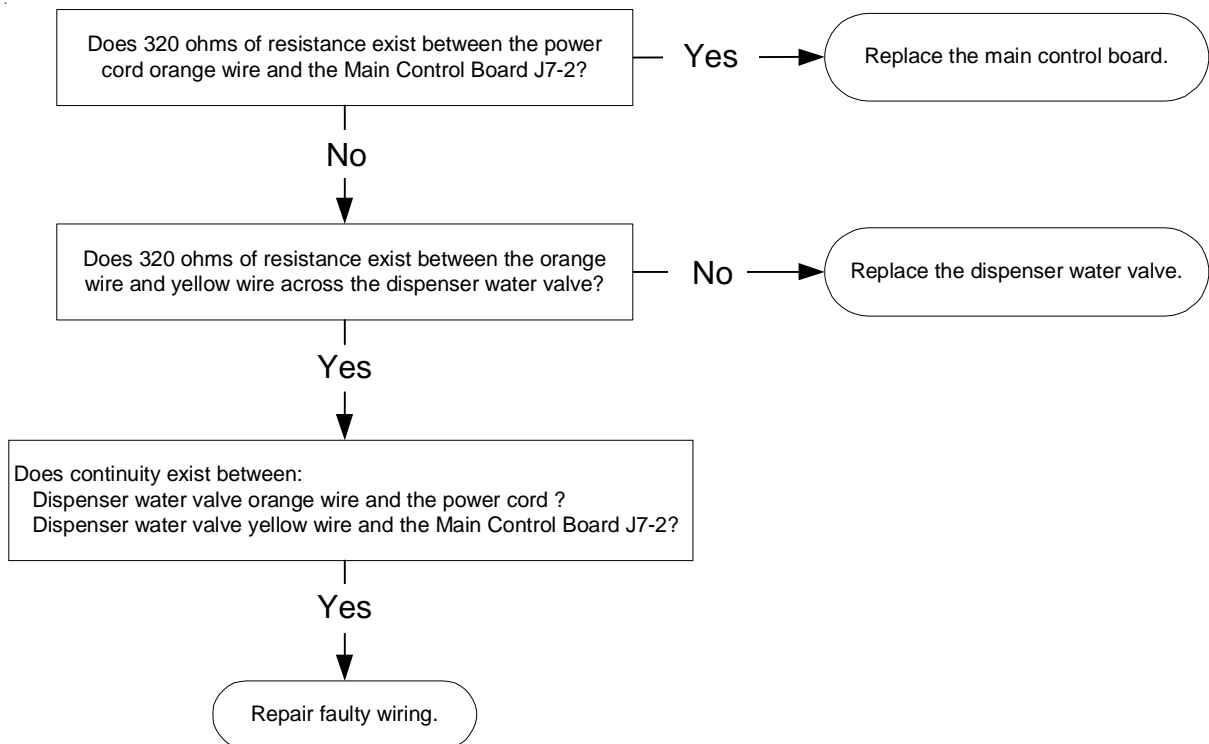

Icemaker Does Not Work

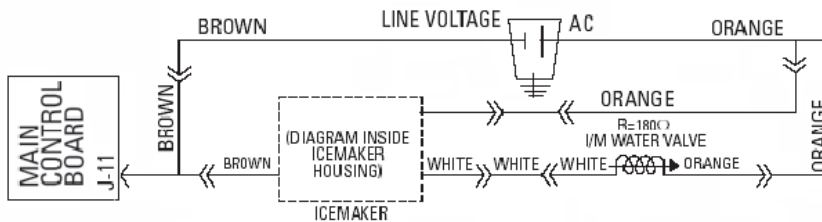
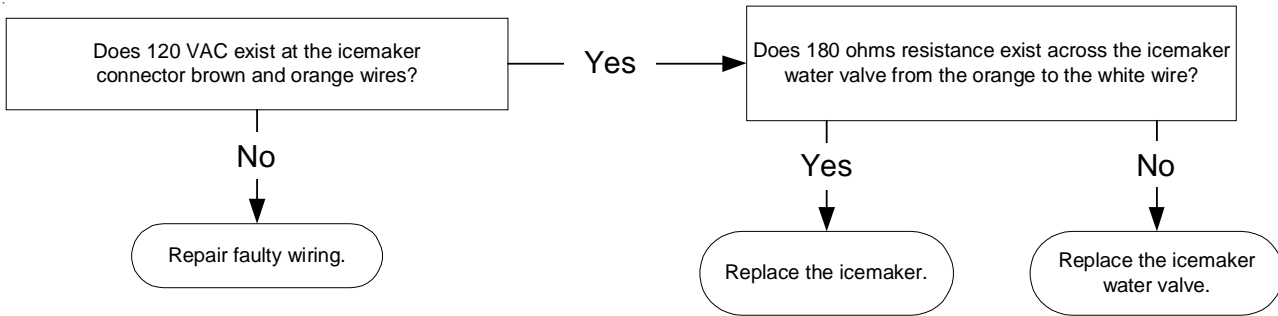

Auger Does Not Work

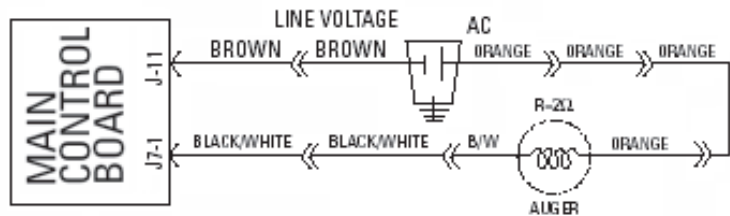
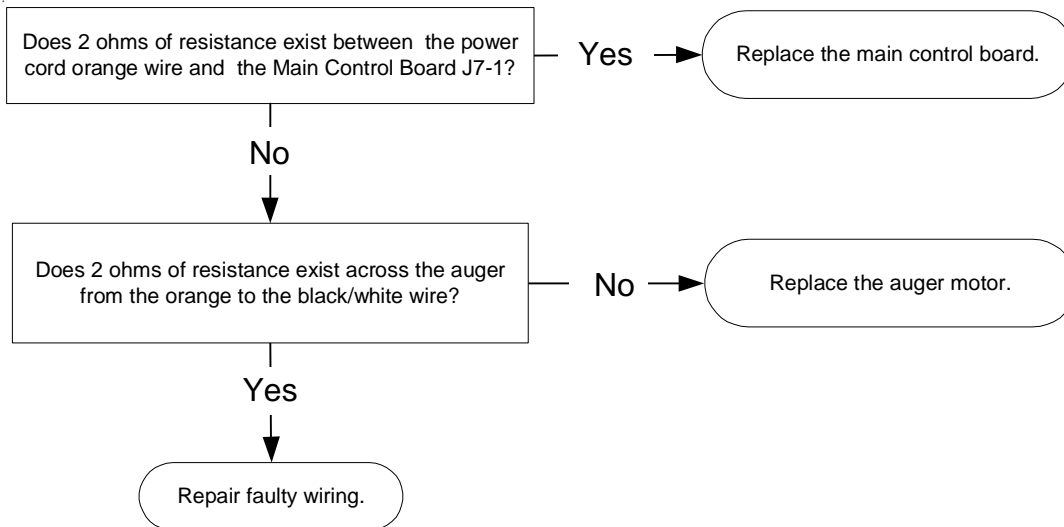

Schematic

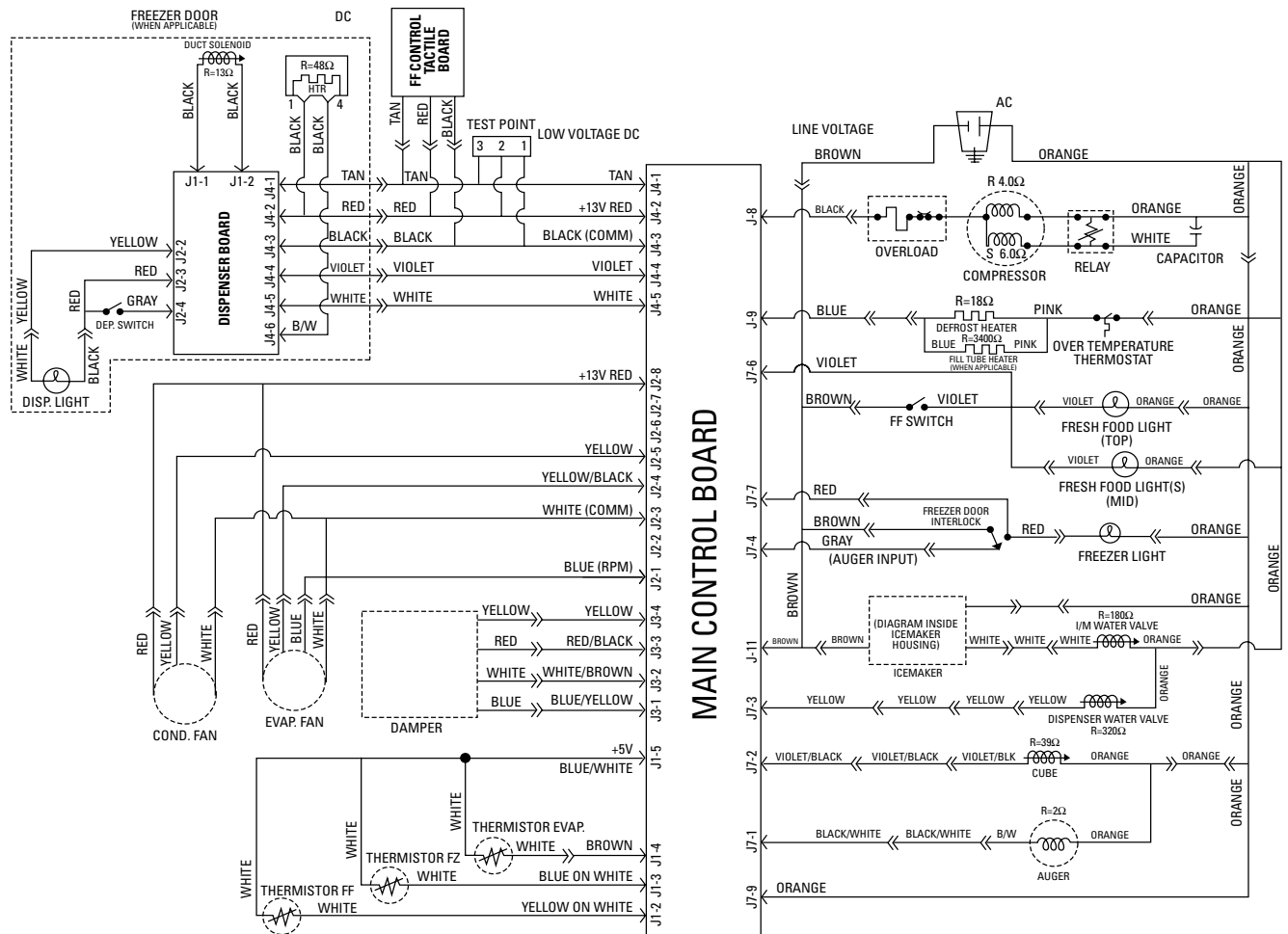

WARNING: Disconnect electrical power before servicing.

Caution: Label all wires prior to disconnection. Wiring errors can cause improper and dangerous operation. Verify operation after servicing.

Wiring Diagram

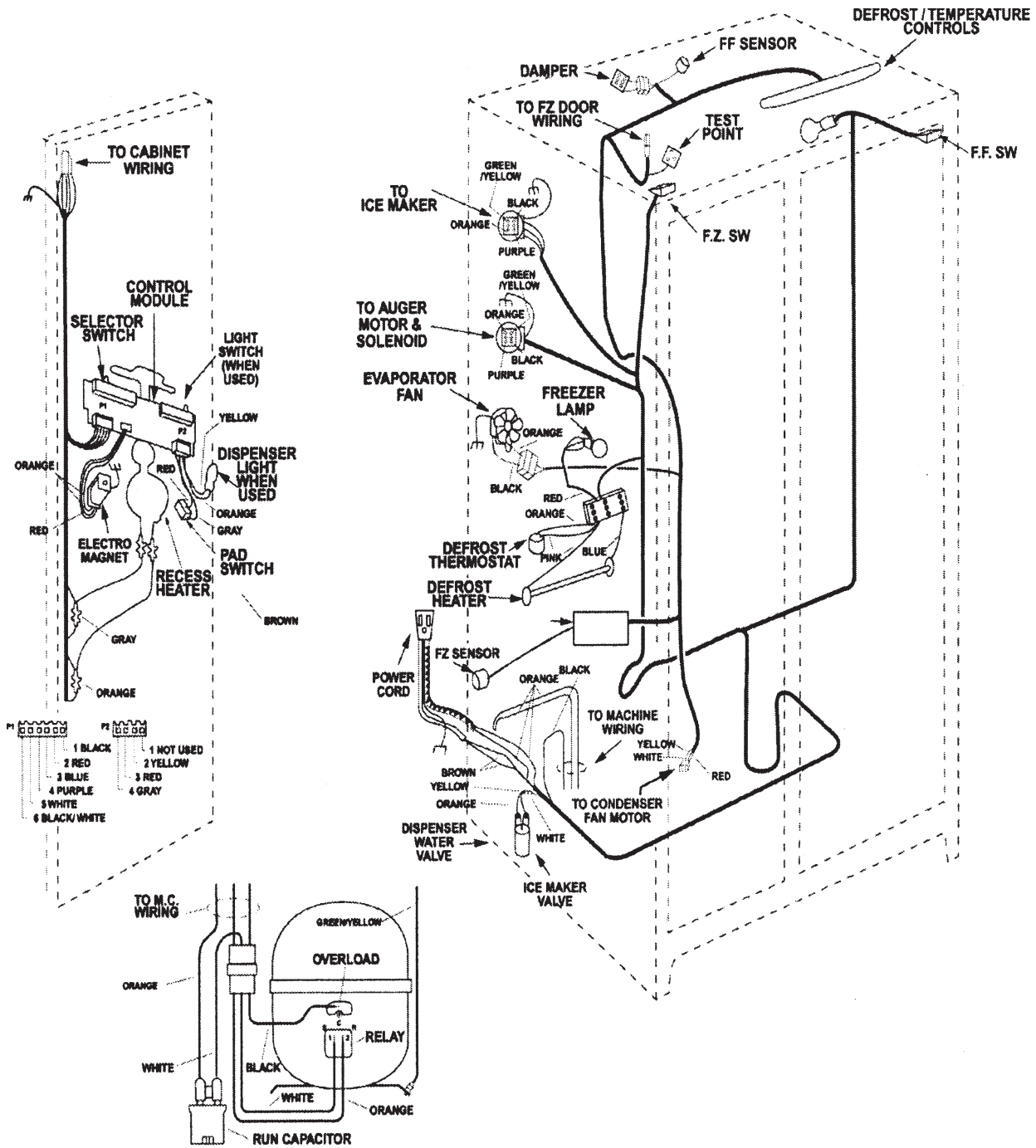

Illustrated Parts Catalog

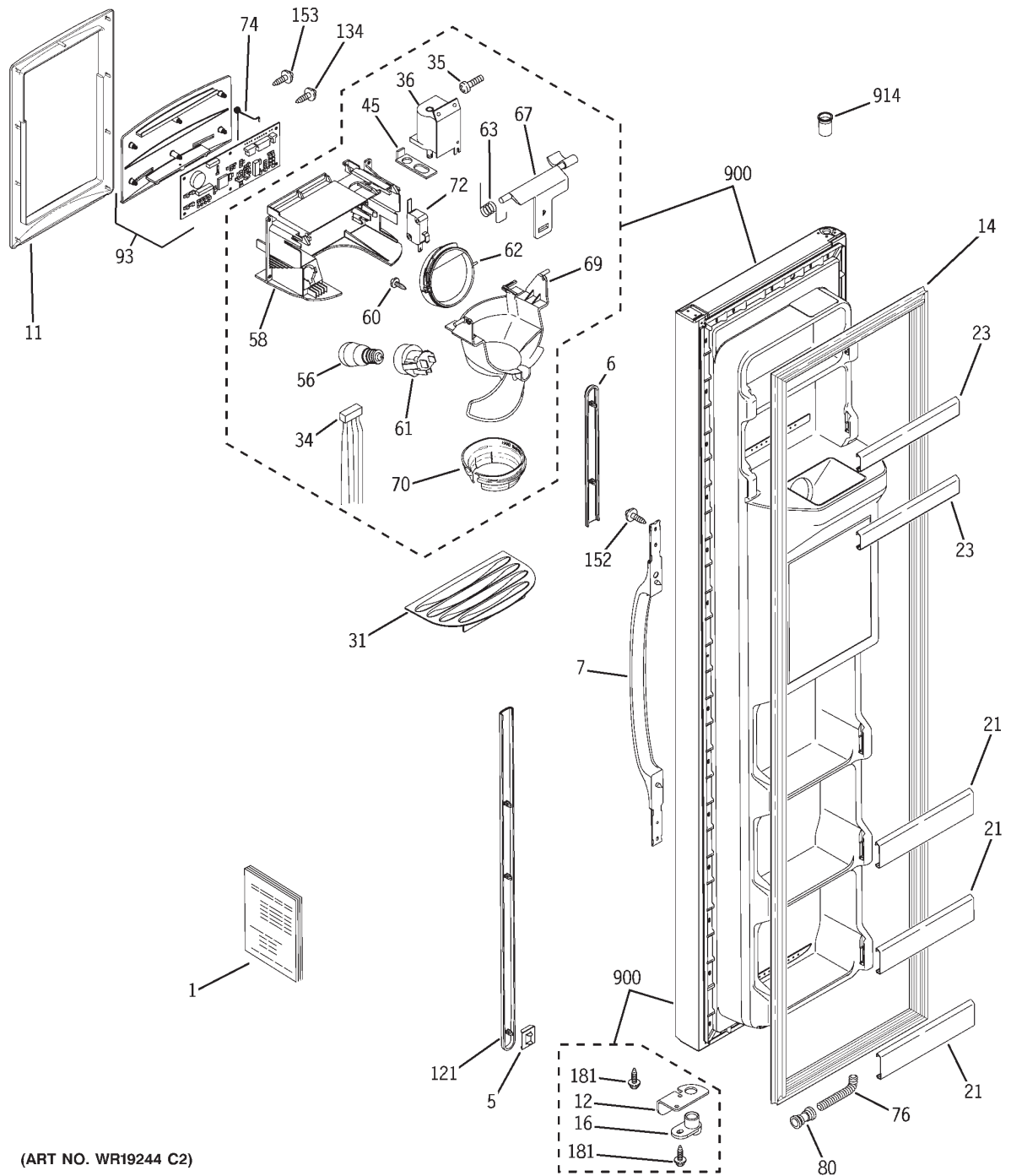

(ART NO. WR19244 C2)

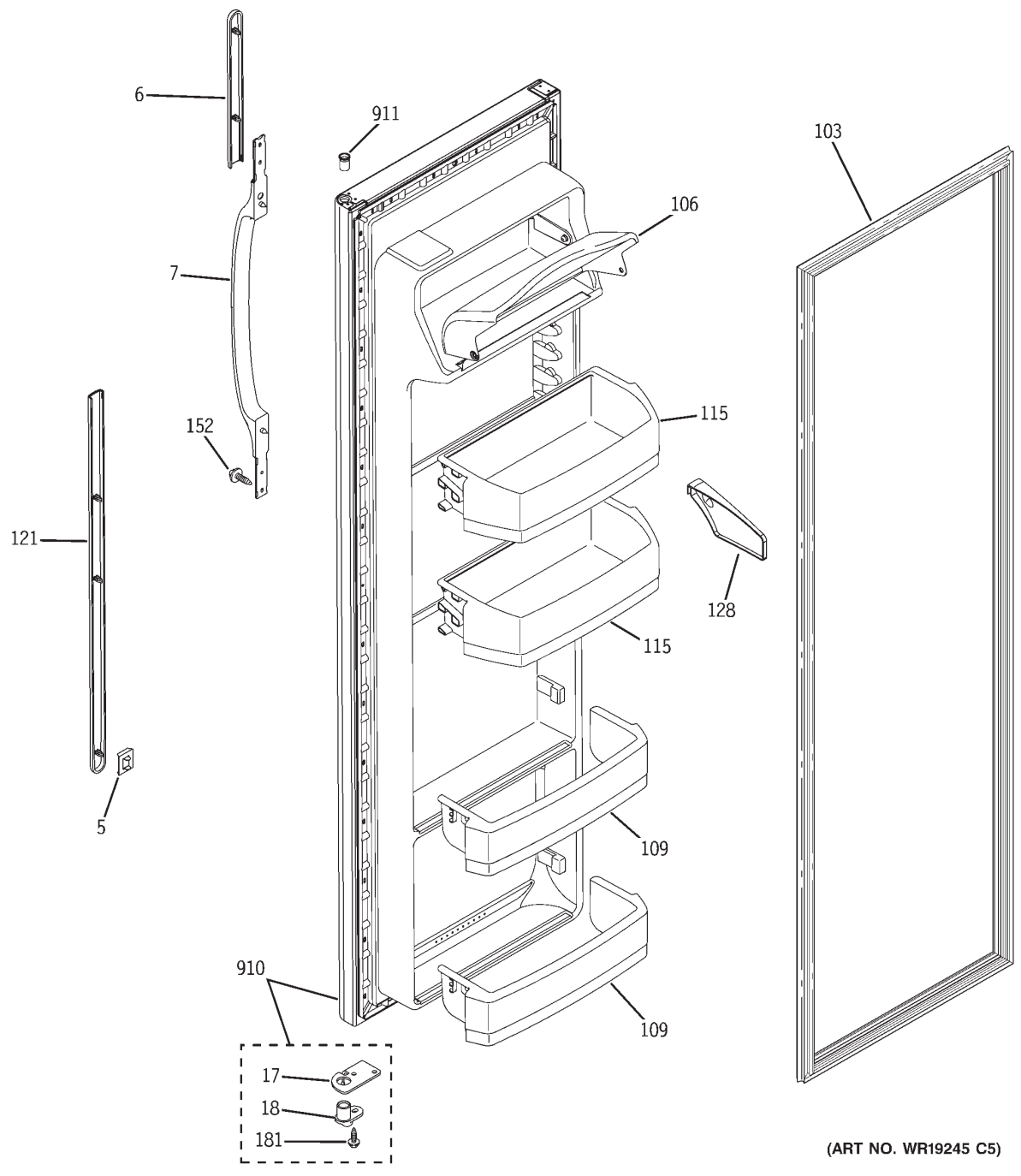

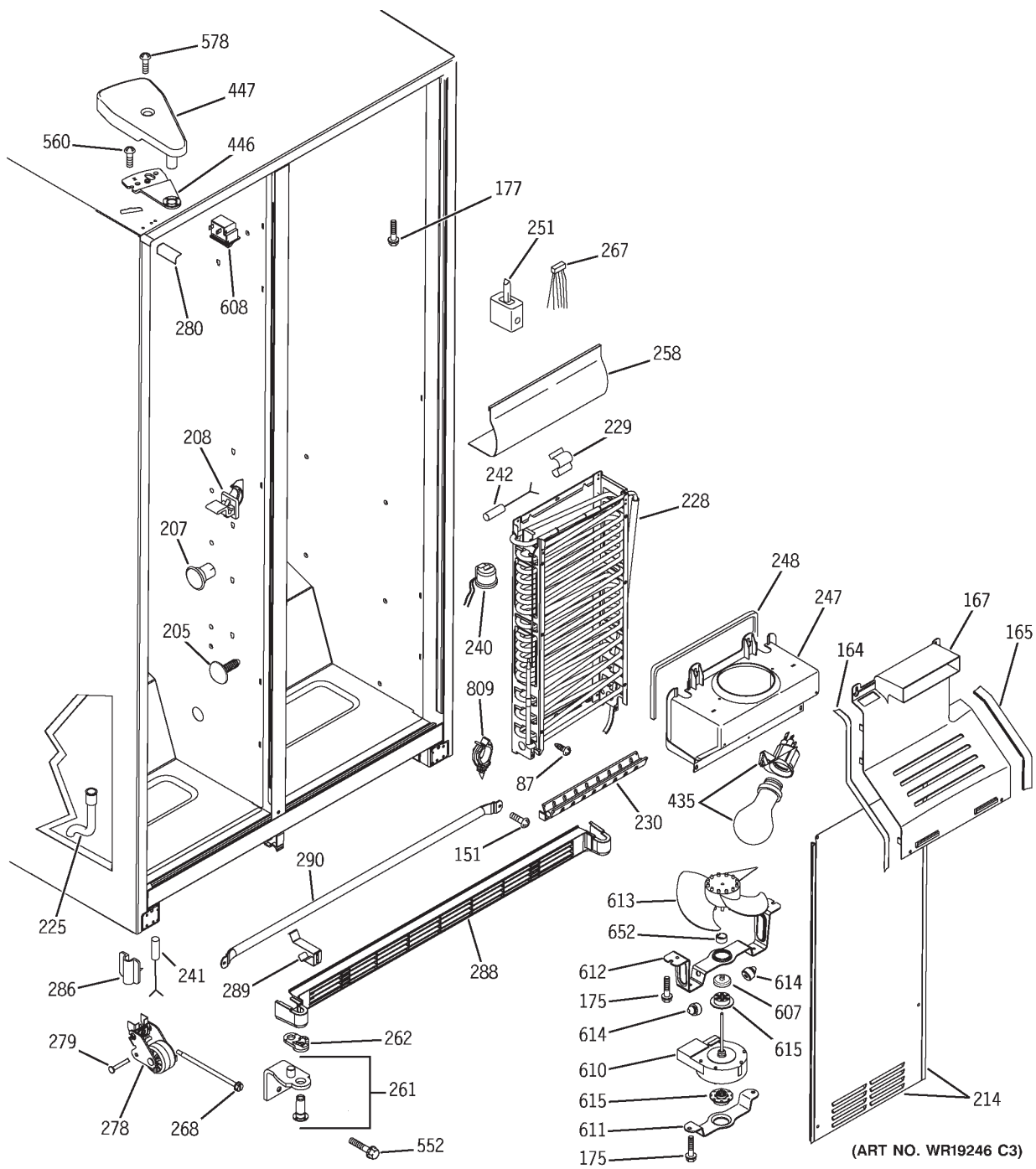

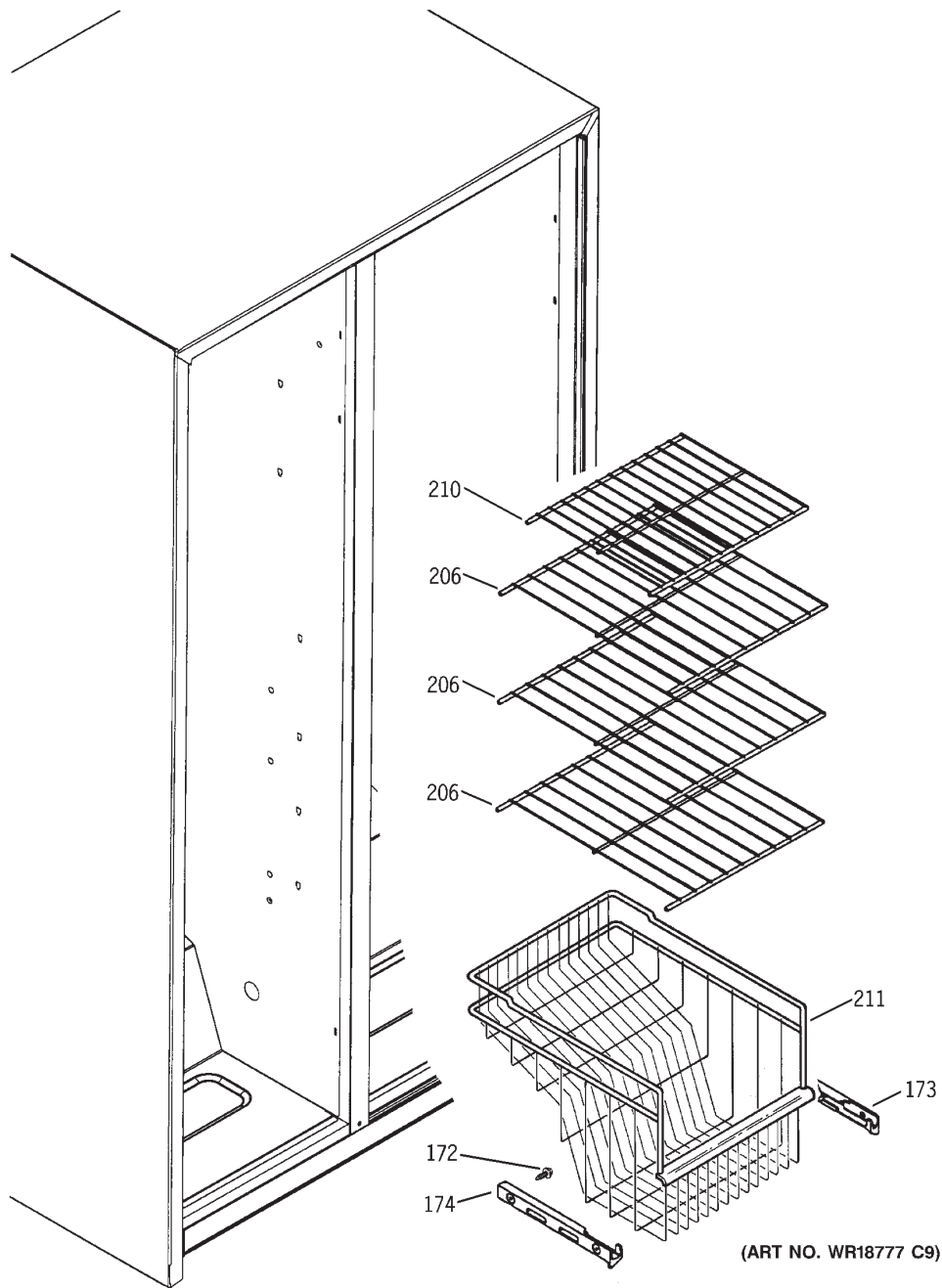

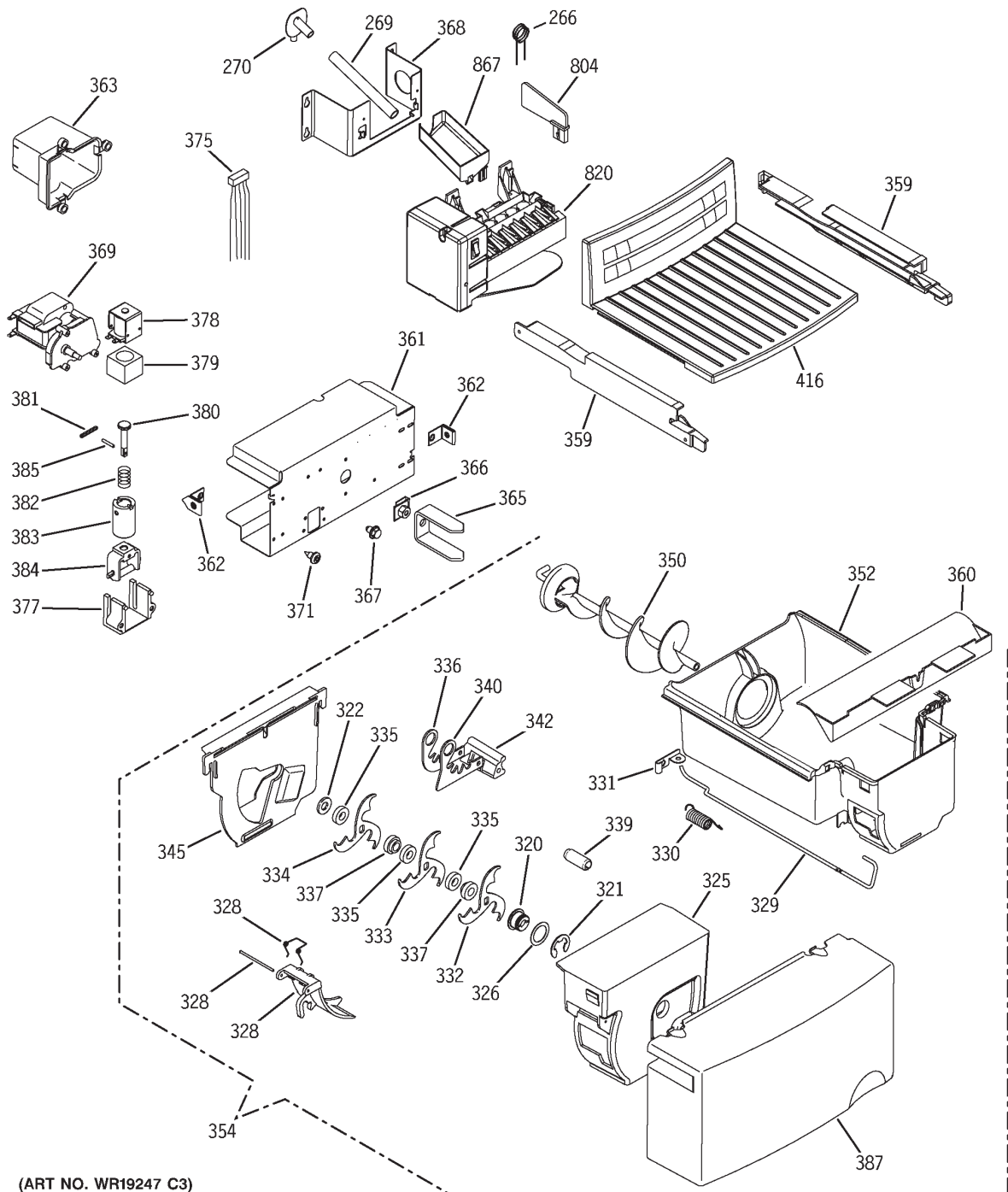

(ART NO. WR19247 C3)

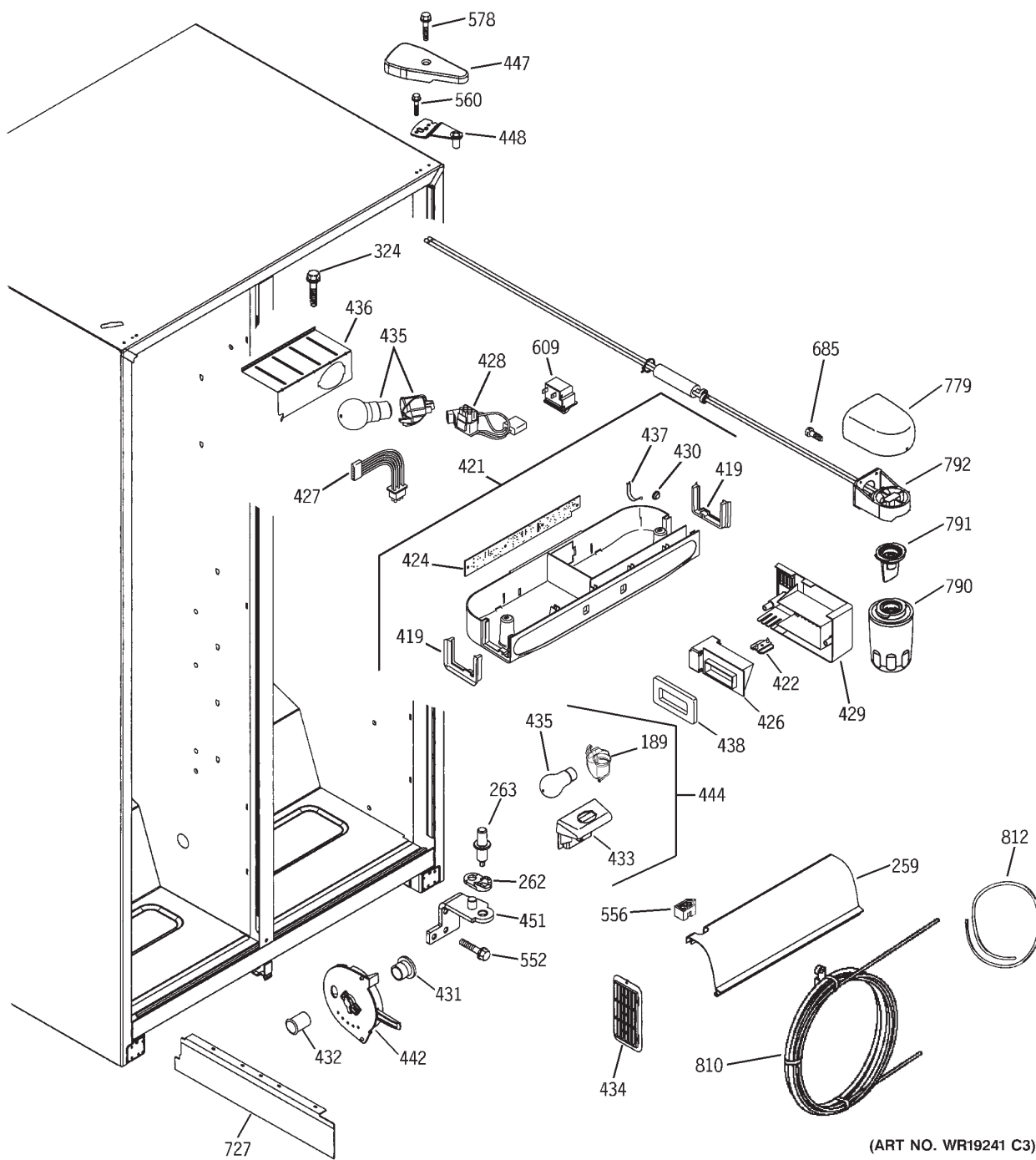

(ART NO. WR19241 C3)

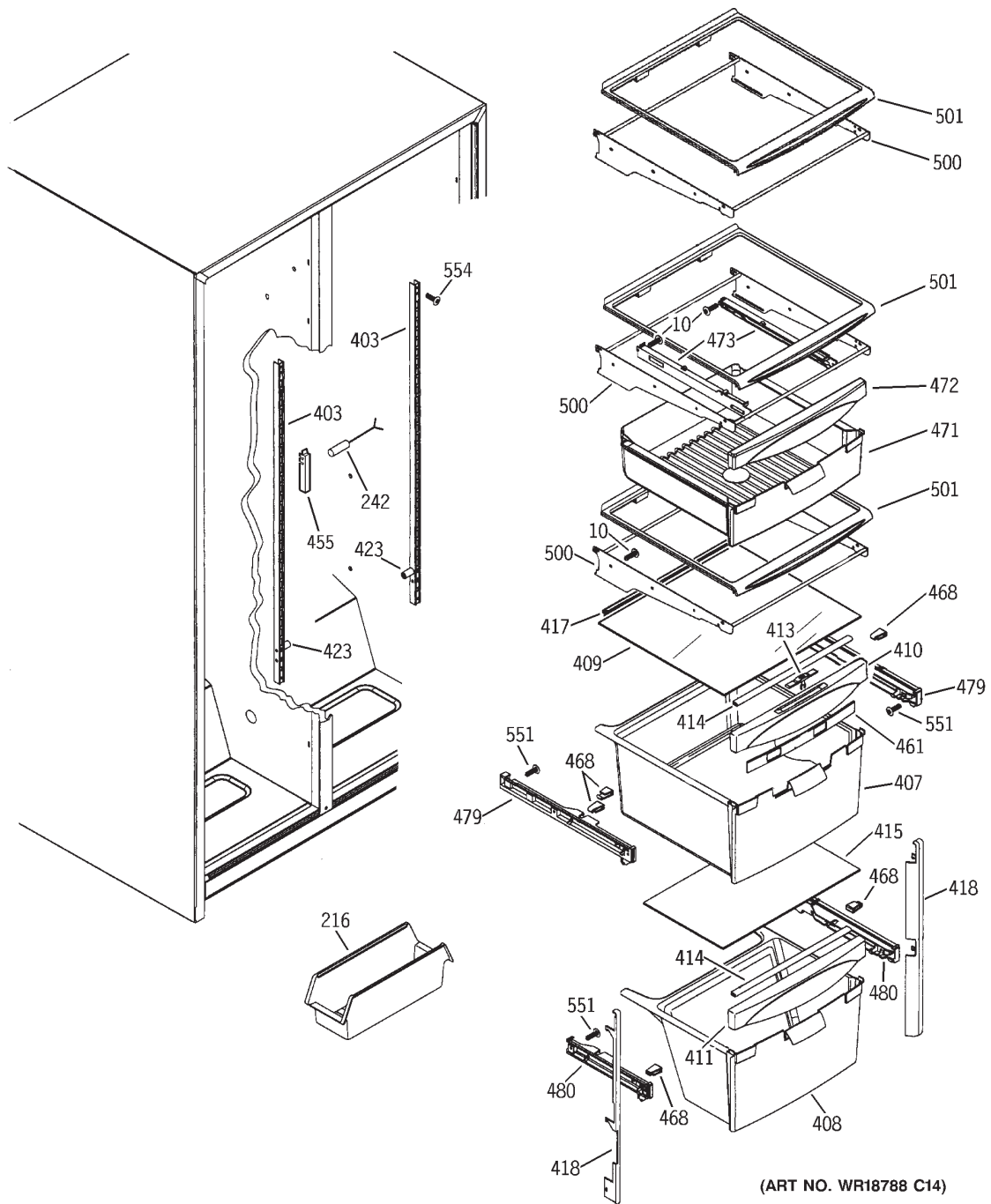

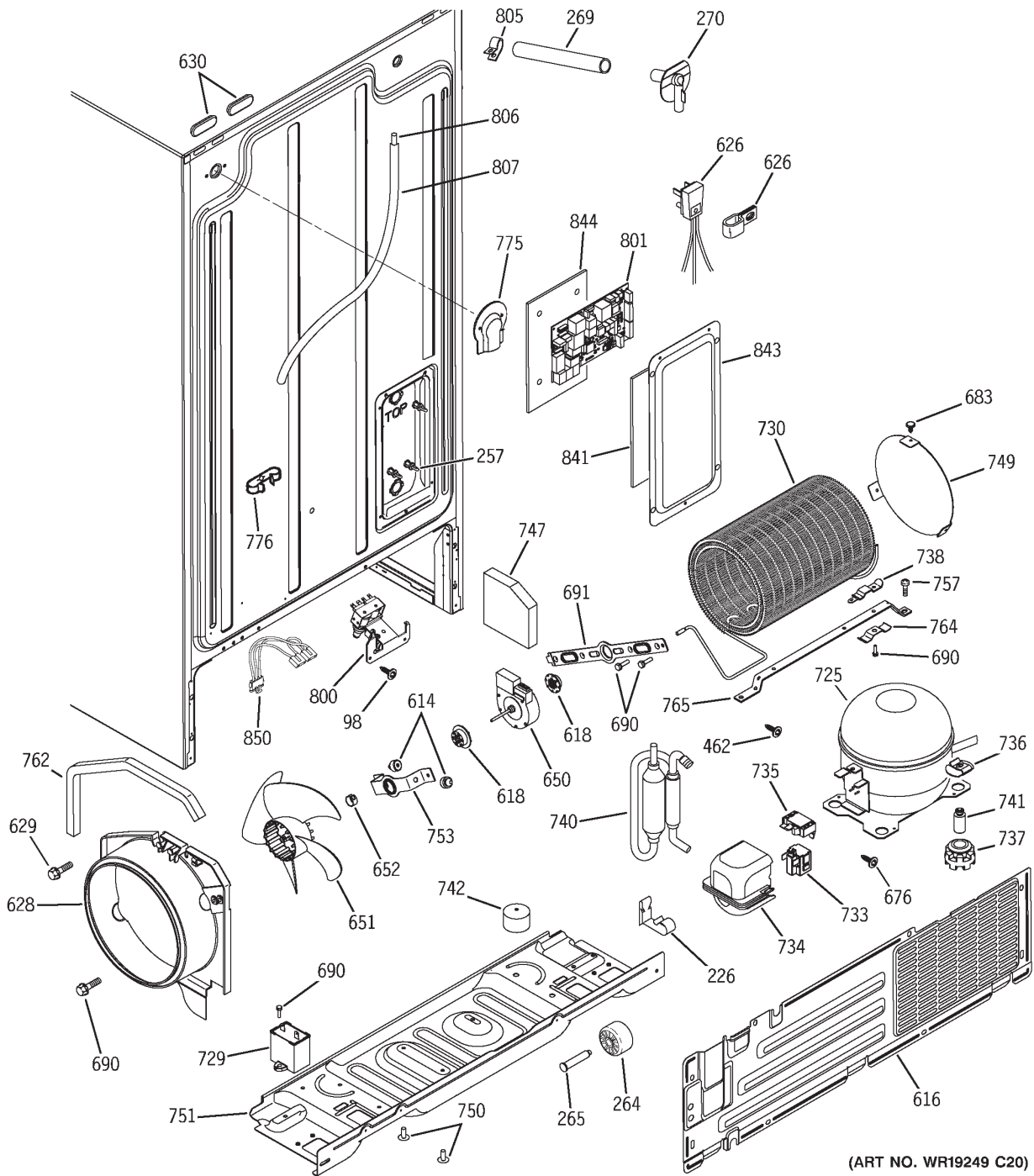

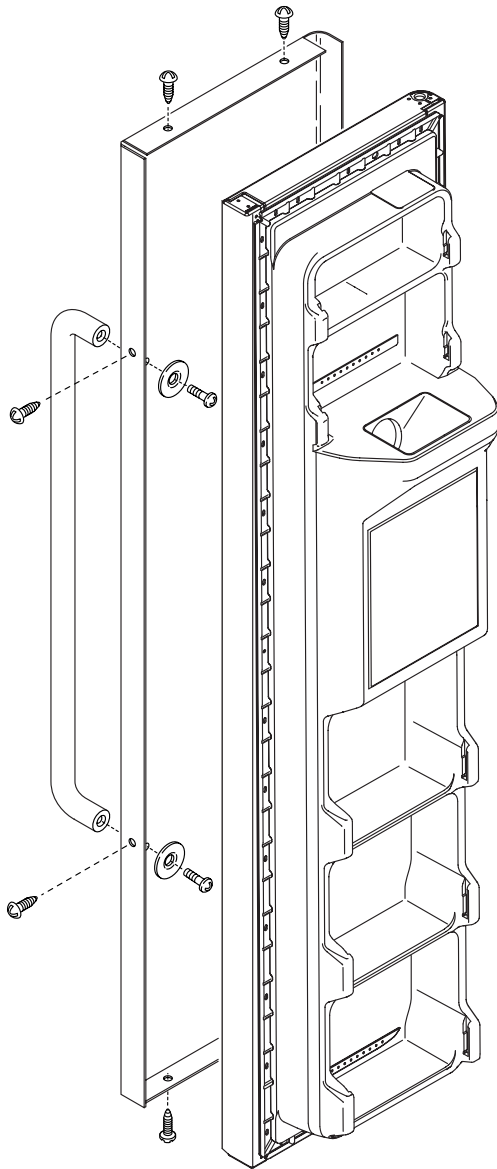

Warranty Information

Refrigerator Warranty. (For customers in the United States)



All warranty service provided by our Factory Service Centers, or an authorized Customer Care® technician. To schedule service, on-line, 24 hours a day, contact us at www.GEAppliances.com, or call 800-GE-CARES.

Staple your receipt here.
Proof of the original purchase date is needed to obtain service under the warranty.

For The Period Of:	GE Will Replace:
One Year From the date of the original purchase	Any part of the refrigerator which fails due to a defect in materials or workmanship. During this full one-year warranty , GE will also provide, free of charge , all labor and in-home service to replace the defective part.
Five Years From the date of the original purchase	Any part of the sealed refrigerating system (the compressor, condenser, evaporator and all connecting tubing) which fails due to a defect in materials or workmanship. During this additional four-year limited warranty , GE will also provide, free of charge , all labor and in-home service to replace the defective part.

What GE Will Not Cover:

- Service trips to your home to teach you how to use the product.
- Improper installation.
- Failure of the product if it is abused, misused, or used for other than the intended purpose or used commercially.
- Loss of food due to spoilage.
- Replacement of house fuses or resetting of circuit breakers.
- Damage to the product caused by accident, fire, floods or acts of God.
- Incidental or consequential damage caused by possible defects with this appliance.

This warranty is extended to the original purchaser and any succeeding owner for products purchased for home use within the USA. In Alaska, the warranty excludes the cost of shipping or service calls to your home.

Some states do not allow the exclusion or limitation of incidental or consequential damages. This warranty gives you specific legal rights, and you may also have other rights which vary from state to state. To know what your legal rights are, consult your local or state consumer affairs office or your state's Attorney General.

Warrantor: General Electric Company. Louisville, KY 40225